

Haier

Engineering Data Book

R290 Super Aqua Monobloc GT



The original documentation is written in English. All other languages are translations.

CONTENTS





1. Safety Precautions	1
1.1 General Guidelines.....	1
1.2 Meaning of Warnings and Symbols.....	1
1.3 Safety Measures for Workers	1
1.4 Safety Warnings for Users.....	3
2. Precautions for Using R290 Refrigerant.....	5
3. General Information.....	11
3.1 Nomenclature	11
3.2 Certificates and Regulations	12
3.3 Lineup.....	13
3.4 Features and Benefits	14
4. Specifications	15
5. Dimensions	48
6. Center of Gravity	54
7. Piping Diagrams	56
8. Wiring Diagrams	60
8.1 Wiring diagram of communication and power cables.....	60
8.2 Wiring diagram of PCB.....	62
9. Electric Characteristics.....	76
10. Capacity Tables	77
10.1 Cooling capacity	77
10.2 Heating capacity.....	81
11. Operation Limits Delivery-Leaving.....	95
12. Water Pressure Drop	98
13. Water Pump Characteristic Curve.....	106
14. Sound Level	108
15. PCB Photos	112
16. Dip Switch Setting	124
17. Sensor Resistance Table	125
18. Accessories.....	129
19. Recommended External Device Specification.....	130
20. Manual Updates Versions	131

1. Safety Precautions









1.1 General Guidelines

1. The precautions described in this document cover very important topics related to safety, please read carefully.
2. Only licensed electricians and water system installers should perform all electrical and water installation works, in accordance with local regulations.
3. After completing the installation/repair work, make sure that the unit operates normally by carrying out test run operation.
4. Instruct the customer how to operate and maintain the unit and explain the cautions to the customer.
5. Keep this manual for future reference.





1.2 Meaning of Warnings and Symbols

	WARNING Indicates a situation that could result in death or serious injury.
	CAUTION Indicates a situation that could result in minor or moderate injury. It may also be used to alert against unsafe practices.
	This symbol with white background indicates item that must be PROHIBITED.
	This symbol with black background indicates item that must be carried out.







1.3 Safety Measures for Workers

WARNING	
	For electrical work, must ensure to follow the local regulations, wiring standards and installation manual.
	For water circuit installation work, must ensure to follow the relevant European and national regulations and local plumbing and building regulation codes.
	Do not store the units near sources of fire, such as open flames, gas appliances, or electric heaters.
	Must ship and store the units in upright conditions and dry area.
	Must disconnect the power cable from the socket prior to disassembling equipment for repair to avoid electrical shocks. Never touch electrically charged sections of the equipment if power supply is necessary for repair or circuit inspection.
	Do not contact with discharged refrigerant gas during repair as it can cause frostbite.
	Must ensure complete evacuation of the refrigerant gas in a well-ventilated place before disconnecting the suction or discharge pipe of the compressor at the welded section. In case of gas remaining inside the compressor, disconnection of the pipe can lead to discharge of refrigerant gas or refrigerating machine oil, which may cause injury.
	Must ensure good ventilation if refrigerant gas leaks during repair as refrigerant gas may generate toxic gases when it contacts flames.
	Must discharge the capacitor completely prior to repair to avoid electrical shocks as it supplies high-voltage electricity to the outdoor unit's electrical components.













WARNING









	Do not plug in or unplug the power cable to turn the air conditioner on or off as it may cause an electrical shock or fire.
	Must wear a safety helmet, gloves, and a safety belt to prevent falls when working in high places (more than 2 m or 6.5 ft).
	Must use exclusively designed pipes, flare nuts, and tools for R32, R410A and R290 refrigerant models to avoid serious accidents like damage to the refrigerant cycle or equipment failure.
	Do not mix air or any gas other than the specified refrigerant (R32, R410A, R290) in the refrigerant system to avoid excessively high pressure that could result in equipment damage and injury.

CAUTION

	Do not repair electrical components with wet hands to avoid electrical shocks.
	Do not clean the units with water; it can cause electrical shocks.
	Must ensure proper grounding when working in a humid or wet place to avoid electrical shocks.
	Must switch off the power and unplug the cable when cleaning the equipment. The internal fan rotates at a high speed, and may cause injury.
	Must use appropriate tools for repairs to avoid injury.
	Must ensure the refrigerating cycle section has cooled down enough before conducting repair work to avoid burns.
	Must conduct welding work in a well-ventilated place to avoid oxygen deficiency.









1.4 Safety Warnings for Users

WARNING	
	Do not store the units near sources of fire, such as open flames, gas appliances, or electric heaters.
	Only use the parts in the spare parts list for the specific model and appropriate tools when performing repairs. Modifying the equipment is strictly prohibited as it can lead to electrical shocks, excessive heat or fire.
	Replace power cables and lead wires if they show signs of damage or deterioration or it may cause electrical shocks, excessive heat or fire.
	Do not use a joined power cable or extension cable, or share the same power outlet with other electrical appliances. This can cause electrical shocks, excessive heat or fire.
	Must ensure to use an exclusive power circuit for the equipment. Follow local technical standards, internal wiring regulations and the installation instruction manual when conducting electrical work. Improper electrical work or insufficient power circuit capacity can cause electrical shocks or fire.
	Must use the specified cable for wiring between the indoor and outdoor units and ensure the connections are secure and the cable is routed properly to avoid any force pulling at the connection terminals. Improper connections can lead to excessive heat or fire.
	Must ensure the terminal cover doesn't lift or dismount due to the cable during wiring. If the cover isn't mounted correctly, it can cause electrical shocks, excessive heat or fire.
	Do not damage or modify the power cable as it can cause electrical shocks or fire. Do not place heavy items on the power cable, or heating or pulling the cable.
	Only use the specified refrigerant (R32, R410A, R290) in the refrigerant system. If air enters into the system, it can result in high pressure, causing equipment damage and injury.
	Must locate and repair the leak first before recharging the refrigerant if refrigerant gas leaks. Ensure there are no leaks after recharging. If leaks can't be located and repair work needs to be halted, pump-down and close the service valve to prevent refrigerant gas from leaking into the room. While refrigerant gas is harmless, it may produce toxic gases upon contact with flames.
	Must ensure the new installation site can support the weight of the equipment when relocating the equipment. If not properly installed or the site lacks sufficient strength, the equipment can fall and cause injury.
	Must ensure the power cable plug is clean and securely inserted into the power outlet. A dirty or loose plug can cause electrical shocks or fire.
	Must ensure the dispose of old batteries from the remote controller to prevent children from swallowing them. If a child does swallow a battery, seek immediate medical attention.







CAUTION	
	A leakage breaker may be required depending on installation site conditions to prevent electrical shocks.
	Do not install the equipment in an area where combustible gas leaks may occur as this can cause a fire.
	Must confirm that parts and wires are properly mounted and connected, and that connections at soldered or crimped terminals are secure. Improper installation or connections can cause excessive heat, fire or electrical shocks.
	Must ensure to replace corroded installation platforms or frames as it can cause the unit to fall and result in injury.
	Must ensure proper earthing/grounding and repair if necessary. Improper earthing/grounding can cause electrical shocks.
	Must measure insulation resistance after repair and ensure that the resistance is 1 MΩ or above. Faulty insulation can cause an electrical shock.
	Must check the drainage of the indoor unit after repair. Faulty drainage can cause water damage to furniture and flooring.
	Do not tilt the unit when removing it. Water inside the unit may spill and damage furniture or flooring.



2. Precautions for Using R290 Refrigerant





Please pay attention to the following points:





WARNING	
	Do not mix any different refrigerants within a system.
	Well trained and certified personnel are required for operating, maintaining, repairing, and recovering the flammable refrigerants, and also for conducting any operation, servicing and maintenance on a system or relevant parts of the units.
	Do not store any of the parts of refrigeration circuit or pipes near sources of fire, such as open flames, gas appliances, or electric heaters.
	The alarms, mechanical ventilation and detectors must be checked regularly by users or the authorized dealer at least once a year based on the national rules to ensure correct operation.
	It is necessary to keep a logbook and record all outcomes of these checks.
	Ventilation in occupied areas must be checked to make sure there are no any obstructions.
	Before a new refrigeration system is put into operation, the person in charge of system operation should ensure that the operating personnel are properly trained and certified and familiarized with the system's construction, supervision, operation and maintenance, safety precautions, and the properties and handling of the refrigerant used.
	For the trained and certified personnel, they must: <ol style="list-style-type: none"> 1. Well understand the legislation, regulations, and standards related to flammable refrigerants; 2. Own the knowledge and skills in managing flammable refrigerants, personal protective equipment, preventing refrigerant leaks, handling cylinders, charging, leak detection, recovery and disposal; 3. Be able to comprehend and apply national legislation, regulations and standards; 4. Keep continuous, regular and additional training to maintain these skills.
	Must protect the protection devices, refrigeration circuits, and fittings from potentially damaging environmental factors, such as the risk of water collection and freezing in relief pipes or the accumulation of dirt and debris.



CAUTION	
Installation	
	Must follow all related national gas regulations, state municipal regulations and laws, and notify the relevant authorities as per all applicable rules.
	Must ensure that all mechanical connections are accessible for maintenance purposes.
	Must ensure that all ventilation openings are clear without any obstructions.
	Always reach out to local authorities for proper guidance.

CAUTION	
Servicing	
● Service Personnel	
	Any certified individual working on or breaking into a refrigerant circuit should have a valid certificate from an industry-recognized assessment authority, confirming their ability to safely handle refrigerants per industry assessment specifications.
	Servicing should only be done as recommended by the equipment manufacturer. Maintenance and repairs requiring additional specialized personnel should be done under the supervision of a person competent in the use of flammable refrigerants.
	Servicing should be performed only as recommended by the equipment manufacturer.
	The system should be inspected, regularly monitored and maintained by a trained and certified service personnel employed by the user or responsible party.
	Must ensure no leak during refrigerant charge.
● Work	
	Must ensure conducting safety checks before starting work on systems that contain flammable refrigerants to minimize the risk of ignition.
	Must ensure to follow all related safety precautions before conducting work on the system when repairing the refrigeration system.
	Must ensure the work is conducted under controlled procedures to minimize the risk of a flammable gas or vapor being present.
	Avoid working in enclosed space and ensure a safety distance of at least 2 meters from any source, or establish a free space zone of at least 2 meters in radius.
	Must use suitable protective equipment per the actual situation.
	Must ensure to stay away from any flammable materials and heat-producing items.
● Confirming Refrigerant Existence	
	A suitable refrigerant detector should be used to check the area before and during work to identify potentially combustible environments.
	The leak detection equipment should be non-sparking, adequately sealed, or intrinsically safe.
	If a leak or spill occurs, ventilate the area immediately, stay upwind and avoid the spill/release.
	In the event of a leak or spill, inform individuals downwind of the leak/spill, isolate the immediate hazard area, and restrict unauthorized personnel.
● Fire Extinguisher Availability	
	If any heat-related work is to be done on the cooling equipment or any related parts, relevant fire extinguishing equipment should be accessible.
	Keep a dry powder or CO ₂ fire extinguisher close to the charging area.
● Avoid Ignition Sources	
	When working on a cooling system, avoid using any ignition sources that could risk a fire or explosion.
	Keep all potential ignition sources, including smoking, sufficiently far from the installation, repair, removal, and disposal site where flammable refrigerant could be released.
	Check the area around the equipment before starting work to ensure that there are no flammable hazards or ignition risks.
	Must display "No Smoking" signs.
● Ventilated Area	
	Must ensure the area is open or adequately ventilated before opening the system or conducting any heat-related work.
	Ensure continuous ventilation throughout the work.
	Safely disperse any released refrigerant during ventilation, preferably expelling into the atmosphere outside.

CAUTION	
● Checking for Refrigerating Equipment	
	When changing electrical components, must ensure they are suitable and meet the correct specifications.
	Must ensure to follow the guidelines provided by the manufacturer for maintenance and service.
	Must reach out to the manufacturer's technical support for help if there are any unsure points.
	When using flammable refrigerants during installation, please conduct below checks:
	1. Must ensure ventilation equipment and outlets are not obstructed and are functioning properly.
	2. Must check the secondary circuit for the presence of refrigerant if an indirect cooling circuit is being used.
	3. Must ensure the equipment markings are legible and visible and correct any markings that are not legible.
4. Refrigeration pipes or components should not be exposed to corrosive substances unless they are made of corrosion-resistant materials or are properly protected.	
● Checking for Electrical Devices	
	Maintenance and repairs of electrical components should include initial safety checks and component inspection procedures.
	Initial safety checks should include but not limited to:
	1. Safe discharge of capacitors to prevent sparking.
	2. No live electrical components or wiring exposed during system charging, recovery, or purging.
	3. Continuity of earth bonding.
	Must follow the guidelines provided by the manufacturer for maintenance and service.
	Must reach out to the manufacturer's technical support for help if there are any unsure points.
	If a fault that could compromise safety is present, do not connect the electrical supply to the circuit until it is satisfactorily resolved.
If the fault cannot be immediately corrected but operation must continue, implement a suitable temporary fix.	
The equipment owner must be informed of any issues so that all parties are aware.	
Repairs to Sealed Components	
	Must disconnect all electrical supplies from the equipment before removing any sealed covers during repairs.
	Must ensure there is a permanent form of leak detection located at the most critical point to warn of potential hazards if it is necessary to have an electrical supply during servicing.
	Must pay special attention to ensure that working on electrical components will not change the casing in a way that impacts the level of protection, which includes cable damage, excessive connections, terminals not made to the original specification, seal damage, incorrect fitting of glands, etc.
	Must ensure that the equipment is securely mounted.
	Must check that seals or sealing materials have not degraded to the point that they can no longer prevent the entry of flammable atmospheres.
	Must ensure the replacement parts meet the manufacturer's specifications.
Note	The use of silicone sealant may affect the performance of some types of leak detection equipment. Intrinsically safe components do not need to be isolated before working on them.

CAUTION	
Maintenance of Intrinsically Safe Components	
	Avoid adding any permanent inductive or capacitance loads to the circuit without verifying that this will not surpass the allowed voltage and current for the equipment in operation.
	Only intrinsically safe components can be serviced while powered on in an environment with a potential for combustion.
	Ensure that the testing equipment is correctly rated.
	Only replace components with parts explicitly recommended by the manufacturer. Utilizing non-specified parts could potentially lead to the ignition of refrigerant in the environment due to a leak.
	Must replace components with parts specified by the manufacturer. Any unspecified parts by manufacturer could potentially lead to the ignition of refrigerant in the environment due to a leak.
Cabling	
	Confirm that the cabling will not be exposed to wear, corrosion, extreme pressure, vibration, sharp edges or other damaging environmental conditions.
	Consider the impacts of aging or continuous vibration from compressors or fans during this check.
Detection of Combustible Refrigerants	
	Absolutely avoid the use of potential ignition sources when searching for or detecting refrigerant leaks.
	A halide torch (or any other detector that uses an open flame) should not be used.
Methods for Detecting Leaks	
	The following methods for detecting leaks are considered suitable for all types of refrigerant systems:
	1. Leak detection should be conducted using equipment with a sensitivity of 5 grams per year of refrigerant or better under a pressure of at least 0.25 times the maximum allowable pressure (>0.98MPa, max 3.90MPa). A universal sniffer, for instance.
	2. Electronic leak detectors can be used for flammable refrigerants, but they may require recalibration for adequate sensitivity.
	(The calibration of detector should be done in an area free of refrigerant.)
	3. Ensure the detector does not pose a risk of ignition and is compatible with the refrigerant being used.
	4. The detector should be calibrated to the specific refrigerant used and set to a percentage of the refrigerant's Lower Flammable Limit (LFL), ensuring it doesn't exceed 25%.
	5. Leak-detecting fluids, such as bubble or fluorescent method agents, can be used with most refrigerants. However, detergents with chlorine should be avoided as they can react with the refrigerant and corrode copper piping.
	6. If a leak is suspected, eliminate any potential ignition sources.
7. If a leak requires brazing to repair, all refrigerant must be recovered from the system first. Must follow the related precautions to remove the refrigerant.	
Removal and Evacuation	
	Conventional procedures should be followed when needing to access the refrigerant circuit for repairs or other purposes. Flammability factor must be taken into account, and follow below procedures:
	remove refrigerant ->purge the circuit with inert gas ->evacuate ->purge with inert gas ->open the circuit by cutting
	Brazing is prohibited.
	Recover the refrigerant charge into the appropriate recovery cylinders.
	Purge the system with Oxygen Free Nitrogen (OFN) to ensure safety.
	Repeat this process for several times as necessary.
Compressed air or oxygen is prohibited for this task.	

CAUTION	
	<p>The purging process involves filling the system with OFN until working pressure is achieved, venting to atmosphere, pulling down to a vacuum, and repeating until no refrigerant remains in the system. (Until the concentration of purge gas is 0.25 LFL or less by the leak detector). $\varnothing 0.25LFL = 0.525Vol\%$</p> <p>After the final OFN charge, vent the system down to atmospheric pressure before starting any work.</p> <p>This process is crucial if brazing on the pipework is needed.</p> <p>Must ensure the vacuum pump outlet is located away from any potential ignition sources and in a well-ventilated area.</p>
Charging procedures	
	<p>In addition to standard charging procedures, the following steps should be followed:</p> <ol style="list-style-type: none"> 1. Prevent contamination of different refrigerants when using charging equipment. 2. Use the shortest possible hoses or lines to minimize the amount of refrigerant they can hold. 3. Store cylinders in the correct position as per their instructions. 4. Ground the refrigerating system before charging it with refrigerant. 5. Label the system once charging is complete (if not already). 6. Pay special attention not to overcharge the refrigerating system. <p>Before recharging the system, pressure test it with OFN (refer to “Removal and Evacuation”).</p> <p>After charging, but before commissioning, perform a leak test on the system.</p> <p>Perform a follow-up leak test before leaving the site.</p> <p>Static electricity can build up and create a hazardous situation when charging and discharging refrigerant. To prevent fires or explosions, ground and bond containers and equipment before starting the process.</p>
Decommissioning	
	<p>Before beginning this process, the technician should be thoroughly familiar with the equipment and all its components.</p> <p>It is highly advised that all refrigerants should be safely collected.</p>
	<p>Do not reuse the collected refrigerant.</p>
	<p>Must ensure that the electricity is accessible before starting the task.</p> <ol style="list-style-type: none"> 1. Learn about the equipment and how it operates. 2. Cut off the system's electrical power. 3. Prior to starting the process, confirm that: <ol style="list-style-type: none"> 1) If necessary, mechanical transport tools are ready for moving refrigerant cylinders; 2) all needed personal protection equipment and leak detectors are at hand and used properly; 3) the recovery process is constantly overseen by a qualified individual; 4) Recovery tools and cylinders meet the standard requirements. 4. Ensure that the cylinder is placed on the scales before the recovery begins. 5. Operate the recovery machine by following the guidelines. 6. Avoid overfilling cylinders. (Do not exceed 80% of the cylinder's volume). 7. Must ensure not exceeding the maximum operational pressure of the cylinder, even temporarily. 8. Once the cylinders have been correctly filled and the procedure is done, ensure that the cylinders and equipment are promptly removed from the location and all equipment isolation valves are closed. <p>Charging or discharging the refrigerant might lead to static electricity accumulation, which can be hazardous. To prevent fire or explosion, neutralize static electricity during transfer by grounding and connecting containers and equipment before charging/discharging.</p>

CAUTION	
Labelling	
	Label the equipment to indicate that it has been decommissioned and emptied of refrigerant.
	The label should include the date and signature.
	Ensure that labels on the equipment state that it contains flammable refrigerant.
Recovery	
	It is advised that all refrigerants are safely removed when removing refrigerant from a system, either for servicing or decommissioning.
	Must ensure using suitable refrigerant recovery cylinders if transferring refrigerant into cylinders,.
	Prepare the right amount of cylinders to contain the total system charge.
	All cylinders to be used should be assigned for the recovered refrigerant and labelled for that specific refrigerant (i.e., dedicated cylinders for refrigerant recovery).
	Cylinders should have a fully operational pressure relief valve and associated shut-off valves of good working conditions.
	Recovery cylinders should be evacuated and, if possible, cooled before recovery.
	The recovery equipment should be operational with a set of instructions about the device available and appropriate for flammable refrigerant recovery.
	Ensure the recovery equipment does not create potential ignition risks and is compatible with the refrigerant being used.
	Prepare a set of calibrated weighing scales of good working conditions.
	Hoses should have leak-free disconnected couplings of good working conditions.
	Before using the recovery machine, verify its operational state, proper maintenance, and that any related electrical components are sealed to prevent ignition if a refrigerant leak occurs. Contact the manufacturer if there are any uncertainties.
	Return the recovered refrigerant to the refrigerant supplier in the correct recovery cylinder, and arrange the relevant Waste Transfer Note.
	Refrigerants should not be mixed in recovery units, and especially not in cylinders.
	If compressors or compressor oils need to be removed, they should be evacuated to an acceptable level to ensure no flammable refrigerant remains in the lubricant.
	The evacuation process should be completed before returning the compressor to the suppliers.
Only electrical heating to the compressor body should be used to accelerate this process.	
When draining oil from a system, it should be done safely.	

3. General Information

3.1 Nomenclature

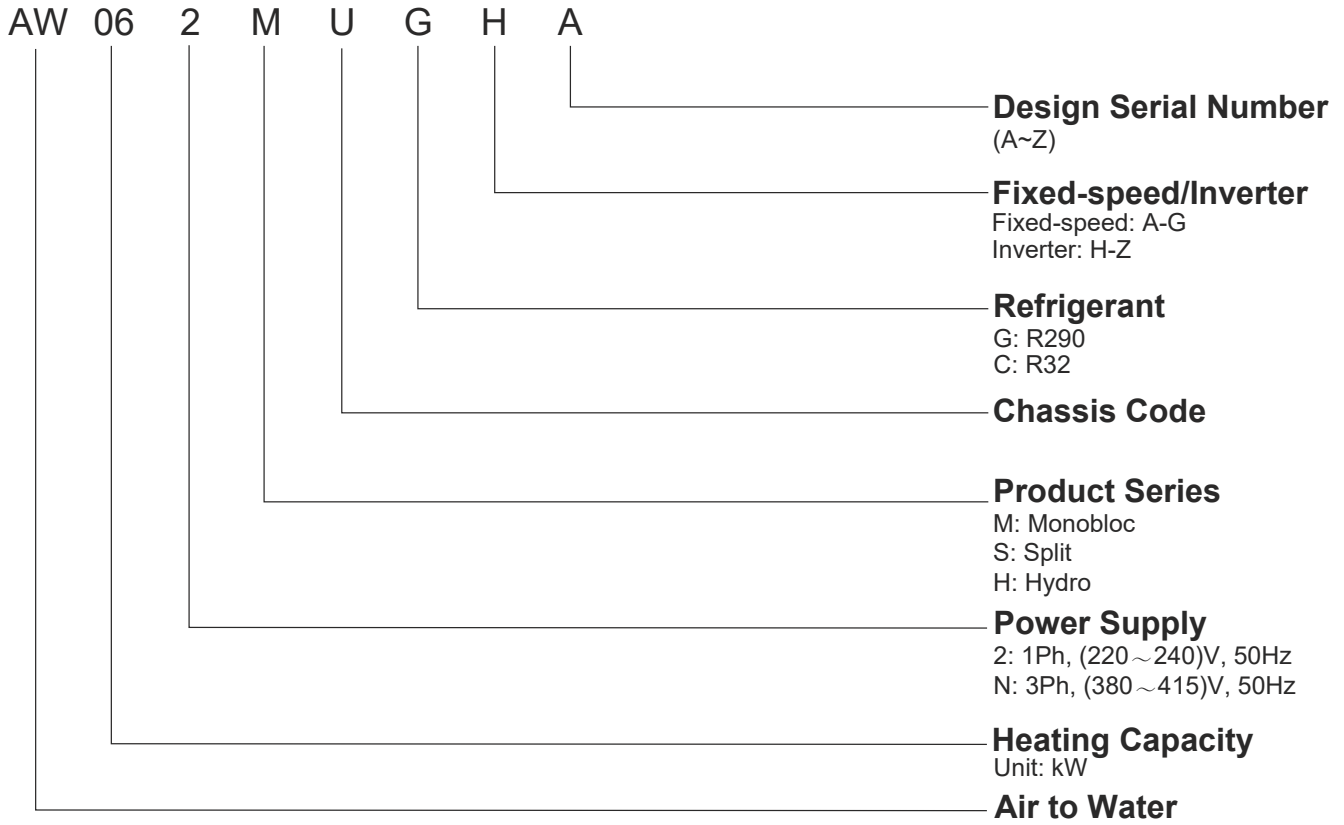

3.2 Certificates and Regulations

EMC directive (2014/30/EU):
EN 55014-1:2021 +A11:2020
EN 55014-2:2021
EN 61000-3-2:2019
EN 61000-3-3:2013+A1:2019

Low-Voltage Directive (2014/35/EU):
EN60335-1:2023+A11:2023
EN60335-1:2012+A13:2017+A1:2019+A14:2019+A2:2019
EN 60335-2-40:2023
ENIEC60335-2-40:2023 +A11:2022
EN60335-2-40-2003/A13-2012
EN 62233:2008

Machinery Directive(2006/42/EC):
EN60335-1:2023+A11:2023
EN60335-1:2012+A13:2017+A1:2019+A14:2019+A2:2019+A15:2021
EN 60335-2-40:2023
ENIEC60335-2-40:2023 +A11:2022
EN60335-2-40-2003/A13-2012
EN 62233:2008

Directive 2014/68/EU (PED)
EN 378-2:2020
EN 14276-2:2020+A1:2011

Directive 2011/65/EU (RoHS)
IEC 62321

3.3 Lineup



Model	Dimension W/D/H	Power Supply (V/Ph/Hz)	Capacity	Compressor type	Heat exchanger	A/C mode	Hydraulic module	Refrigerant
AW042MUGHA	1250*380*790	220~230/1/50	4KW	DC Inverter	Plate-heat Exchanger	Heat Pump	Built-in	R290
AW062MUGHA			6KW					
AW082MUGHA			8KW					
AW102MUGHA			10KW					
AW10NMUGHA		380~415V/3/50	10KW					



Model	Dimension W/D/H	Power Supply (V/Ph/Hz)	Capacity	Compressor type	Heat exchanger	A/C mode	Hydraulic module	Refrigerant
AW122MXGHA	1380*460*880	220~230/1/50	12KW	DC Inverter	Plate-heat Exchanger	Heat Pump	Built-in	R290
AW142MXGHA			14KW					
AW162MXGHA			16KW					
AW12NMXGHA		380~415V/3/50	12KW					
AW14NMXGHA			14KW					
AW16NMXGHA			16KW					

3.4 Features and Benefits

Environmental-friendly

- **Natural refrigerant R290**

High-efficiency

The GT series performs excellently as a result of the following: a higher compression ratio, less oil compressors and an efficient internal thread regenerator are used in the appliance to increase the suction temperature. In turn, improving the units energy efficiency, reaching a maximum COP value of 5.50 can be reached.

- **SCOP A+++/A+++ (35°C/55°C)**

The SCOP at 35°C and 55°C water temperature both reach the top class A+++.

- **Hot water ERP class A+**

DHW efficiency level reaches the top class A+.

Ultimate Comfort

- **High leaving water temperature**

The maximum leaving water temperature can reach 80°C, an industry leading figure. The GT series is the best solution to replace the boiler heating.

- **Low sound level**

With excellent design, the Haier Super Aqua GT series sound pressure level is as low as 55dB(A).

Super Convenience

Easy installation and easy maintenance

The internal structural layout has been optimized to allow for easy installation and maintenance. Components can be removed and assembled without interfering with one another.

High Reliability

- **Wide operating range**

The GT series can operate normally at minus 25°C, guaranteeing the users warmth in cold weather.

- **Silver brazing technology**

Optimisation of system design by reducing the number of welding joints alongside adopting silver brazing, ensures a stronger weld and avoids any leakage of the R290 refrigerant, which is combustible.

- **Refrigerant separator**

The refrigerant separator quickly removing refrigerant from the water system in case of leakage, preventing the refrigerant from entering the water system or indoor space.

- **Sealed electric control box**

Explosion proof electrical control box design, provides increased safety for R290 products. Used to avoid potential fire hazards and provide protection to users.

Intelligence

- **Smart control**

Haier WIFI control can check the running state of the heat pump, allowing flexibility and control of the unit. Encouraging easier lifestyle choices for the user.

Selection software

Authorised users can access a cloud service enabling the system to be built and designed, accessed via their mobile phone or computer. All ATW heat pump models are available for selection and design, an output report specific to the customers residence is produced, allowing a project plan to be constructed.

4. Specifications

Product Data		Unit	AW042MUGHA
Heating (LWT 35°C / OAT 7°C)	Capacity	kW	4.00
	Power input	kW	0.73
	COP	W/W	5.50
Heating (LWT 55°C / OAT 7°C)	Capacity	kW	4.00
	Power input	kW	1.19
	COP	W/W	3.35
Space Heating Average Climate Water Outlet 35°C	SCOP	~	5.10
	η_s	%	201
	Energy class	-	A+++
Space Heating Average Climate Water Outlet 55°C	SCOP	-	3.85
	η_s	%	151
	Energy class	-	A+++
Cooling (LWT 18°C / OAT 35°C)	Capacity	kW	4.00
	Power input	kW	0.79
	EER	-	5.05
Cooling (LWT 7°C / OAT 35°C)	Capacity	kW	3.50
	Power input	kW	0.95
	EER	-	3.70
Outdoor Operating Temperature Range	Heating	°C	-25 ~35
	Cooling	°C	10 ~ 48
	DHW	°C	-25 ~43
Leaving Water Temperature Range	Heating	°C	20~80
	Cooling	°C	5~25
Storage Temperature Range(Tank)	DHW	°C	25~75
Water Flow Rate	Standard	m³/h	0.690
	Minimum	m³/h	0.240
Water Piping Connection	Inlet/Outlet	inch	R 1/R 1
Expansion Tank	Tank Volume	L	4.5
	MWP	bar	3
Safety Devices			High pressure switch, Fan driver overload protector, Overcurrent fuse, Inverter overload protector, Refrigerant separator, Safety valve, Expansion vessel
Defrost Method			4WV reverse defrosting
Casing	Color		Slate Grey
	Material		Galvanized steel

Product Data		Unit	AW042MUGHA
Compressor	Brand		MITSUBISHI ELECTRIC
	Type		DC Inverter Twin Rotary
	Compressor Quantity		1
	Rated Load Amps. (RLA)	A	5.80
	Crankcase Heater	W	27
		Quantity	1
	Compressor Oil Brand		IDEMITSUKOSAN CO.,LTD
	Compressor Oil Type		PZ46M
Fan Motor	Compressor Oil Charge(Compressor + Gas-liquid Separator)	ml	380
	Brand		BROAD-OCEAN
	IP Class		IP44
	Type		DC
	Quantity		1
	Insulation Class		E
	Safe Class		I
	Max. Speed	rpm	900
Fan	Brand		Shun wei
	Type		Axial
	Diameter	mm	Ø604
Heat Exchanger	Number of Rows		2
	Tube Pitch	mm	21
	Row Pitch	mm	18.186
	Fin Spacing	mm	1.45
	Fin Type		Hydrophilic aluminum
	Fin Coating Type	Optional	Clear lacquer
	Salt Spray Test Duration	hour	168
	Tube(ID)	mm	φ7
	Tube Type		INNERGROOVE TUBE
Plate Heat Exchanger	Brand		Weyee
Water Pump	Head	m	7.5
Electronic Expansion Valve	LEVa	Brand	SANHUA
Four Way Valve	Brand		SANHUA
	Quantity		1
Pressure Sensor of Discharge	Brand		Sensata/SANHUA
Pressure Sensor of Suction	Brand		Sensata/SANHUA
Temp. Sensor	Temperature Sensor Type		Discharge
	Value of Resistance @20°C /Ω		50K
	Temperature Sensor Type		Suction/Outdoor Ambient/Defrost/ Liquid pipe/Gas pipe/Inlet water/ Outlet water
	Value of Resistance @20°C /Ω		10K

Product Data		Unit	AW042MUGHA
Cabinet Coating	Coating Type		Powder Coating
	Salt Spray Test Duration	hour	72
	Sheet Metal Material		Hot zinc plate
	Sheet Metal Thickness	mm	1
Electrical Control Box IP Class		Standard	IP24
Refrigerant	Type	-	R290
	Charge	kg	0.80
	CO ₂ Eq.	kg	2.40
Net Dimension	H*W*D	mm	790*1250*380
Packing Dimension	H*W*D	mm	1022*1395*595
Net/Gross Weight		kg	94/127
Sound Pressure Level*(1)		dB(A)	44
Sound Power Level*(1)		dB	55
Power Supply		Ph/V/Hz	1/220~240/50
Minimum Circuit Amps(MCA)		A	13.5
Maximum Fuse Amps(MFA)		A	16
Minimum Power Supply Cable		mm ²	4
Accessory	Wired Controller	/	HW-WA101DBT(Standard)*1
	PCB Box	/	ATW-A03N(Standard)*1
	Filter	/	Y-type(Standard)*1
<p>Note:</p> <p>1. Accordng to EN14511, EN14825 (EU) and No 811/2013(EU).</p> <p>2.LWT: Leaving water temperature; OAT: Outdoor air temperature.</p> <p>3.Sound level values are measured in a semi-anechoic room. Sound power level values are based on measurement of EN12102-1 under conditions of EN14825.</p> <p>4.The above data may be changed without notice as a result of future improvement to quality and performance.</p>			

Product Data		Unit	AW062MUGHA
Heating (LWT 35°C / OAT 7°C)	Capacity	kW	6.00
	Power input	kW	1.12
	COP	W/W	5.35
Heating (LWT 55°C / OAT 7°C)	Capacity	kW	6.00
	Power input	kW	1.82
	COP	W/W	3.30
Space Heating Average Climate Water Outlet 35°C	SCOP	~	5.10
	η_s	%	201
	Energy class	-	A+++
Space Heating Average Climate Water Outlet 55°C	SCOP	-	3.83
	η_s	%	150
	Energy class	-	A+++
Cooling (LWT 18°C / OAT 35°C)	Capacity	kW	6.00
	Power input	kW	1.20
	EER	-	5.00
Cooling (LWT 7°C / OAT 35°C)	Capacity	kW	5.00
	Power input	kW	1.37
	EER	-	3.65
Outdoor Operating Temperature Range	Heating	°C	-25 ~35
	Cooling	°C	10 ~ 48
	DHW	°C	-25 ~43
Leaving Water Temperature Range	Heating	°C	20~80
	Cooling	°C	5~25
Storage Temperature Range(Tank)	DHW	°C	25~75
Water Flow Rate	Standard	m³/h	1.032
	Minimum	m³/h	0.360
Water Piping Connection	Inlet/Outlet	inch	R 1/R 1
Expansion Tank	Tank Volume	L	4.5
	MWP	bar	3
Safety Devices			High pressure switch, Fan driver overload protector, Overcurrent fuse, Inverter overload protector, Refrigerant separator, Safety valve, Expansion vessel
Defrost Method			4WV reverse defrosting
Casing	Color		Slate Grey
	Material		Galvanized steel

Product Data		Unit	AW062MUGHA
Compressor	Brand		MITSUBISHI ELECTRIC
	Type		DC Inverter Twin Rotary
	Compressor Quantity		1
	Rated Load Amps. (RLA)	A	5.80
	Crankcase Heater	W	27
		Quantity	1
	Compressor Oil Brand		IDEMITSUKOSAN CO.,LTD
	Compressor Oil Type		PZ46M
Compressor Oil Charge(Compressor + Gas-liquid Separator)	ml	380	
Fan Motor	Brand		BROAD-OCEAN
	IP Class		IP44
	Type		DC
	Quantity		1
	Insulation Class		E
	Safe Class		I
	Max. Speed	rpm	900
Fan	Brand		Shun wei
	Type		Axial
	Diameter	mm	Ø604
Heat Exchanger	Number of Rows		2
	Tube Pitch	mm	21
	Row Pitch	mm	18.186
	Fin Spacing	mm	1.45
	Fin Type		Hydrophilic aluminum
	Fin Coating Type	Optional	Clear lacquer
	Salt Spray Test Duration	hour	168
	Tube(ID)	mm	φ7
	Tube Type		INNERGROOVE TUBE
Plate Heat Exchanger	Brand		Weyee
Water Pump	Head	m	7.5
Electronic Expansion Valve	LEVa	Brand	SANHUA
Four Way Valve		Brand	SANHUA
		Quantity	1
Pressure Sensor of Discharge	Brand		Sensata/SANHUA
Pressure Sensor of Suction	Brand		Sensata/SANHUA
Temp. Sensor	Temperature Sensor Type		Discharge
	Value of Resistance @20°C /Ω		50K
	Temperature Sensor Type		Suction/Outdoor Ambient/Defrost/ Liquid pipe/Gas pipe/Inlet water/ Outlet water
	Value of Resistance @20°C /Ω		10K

Product Data		Unit	AW062MUGHA
Cabinet Coating	Coating Type		Powder Coating
	Salt Spray Test Duration	hour	72
	Sheet Metal Material		Hot zinc plate
	Sheet Metal Thickness	mm	1
Electrical Control Box IP Class		Standard	IP24
Refrigerant	Type	-	R290
	Charge	kg	0.80
	CO ₂ Eq.	kg	2.40
Net Dimension	H*W*D	mm	790*1250*380
Packing Dimension	H*W*D	mm	1022*1395*595
Net/Gross Weight		kg	94/127
Sound Pressure Level*(1)		dB(A)	47
Sound Power Level*(1)		dB	58
Power Supply		Ph/V/Hz	1/220~240/50
Minimum Circuit Amps(MCA)		A	13.5
Maximum Fuse Amps(MFA)		A	16
Minimum Power Supply Cable		mm ²	4
Accessory	Wired Controller	/	HW-WA101DBT(Standard)*1
	PCB Box	/	ATW-A03N(Standard)*1
	Filter	/	Y-type(Standard)*1
<p>Note:</p> <ol style="list-style-type: none"> 1. Accordng to EN14511, EN14825 (EU) and No 811/2013(EU). 2. LWT: Leaving water temperature; OAT: Outdoor air temperature. 3. Sound level values are measured in a semi-anechoic room. Sound power level values are based on measurement of EN12102-1 under conditions of EN14825. 4. The above data may be changed without notice as a result of future improvement to quality and performance. 			

Product Data		Unit	AW082MUGHA
Heating (LWT 35°C / OAT 7°C)	Capacity	kW	8.00
	Power input	kW	1.50
	COP	W/W	5.35
Heating (LWT 55°C / OAT 7°C)	Capacity	kW	8.00
	Power input	kW	2.35
	COP	W/W	3.40
Space Heating Average Climate Water Outlet 35°C	SCOP	~	5.20
	η_s	%	205
	Energy class	-	A+++
Space Heating Average Climate Water Outlet 55°C	SCOP	-	3.85
	η_s	%	151
	Energy class	-	A+++
Cooling (LWT 18°C / OAT 35°C)	Capacity	kW	7.50
	Power input	kW	1.58
	EER	-	4.75
Cooling (LWT 7°C / OAT 35°C)	Capacity	kW	6.80
	Power input	kW	1.97
	EER	-	3.45
Outdoor Operating Temperature Range	Heating	°C	-25 ~35
	Cooling	°C	10 ~ 48
	DHW	°C	-25 ~43
Leaving Water Temperature Range	Heating	°C	20~80
	Cooling	°C	5~25
Storage Temperature Range(Tank)	DHW	°C	25~75
Water Flow Rate	Standard	m³/h	1.374
	Minimum	m³/h	0.540
Water Piping Connection	Inlet/Outlet	inch	R 1/R 1
Expansion Tank	Tank Volume	L	4.5
	MWP	bar	3
Safety Devices			High pressure switch, Fan driver overload protector, Overcurrent fuse, Inverter overload protector, Refrigerant separator, Safety valve, Expansion vessel
Defrost Method			4WV reverse defrosting
Casing	Color		Slate Grey
	Material		Galvanized steel

Product Data		Unit	AW082MUGHA
Compressor	Brand		MITSUBISHI ELECTRIC
	Type		DC Inverter Twin Rotary
	Compressor Quantity		1
	Rated Load Amps. (RLA)	A	7.50
	Crankcase Heater	W	27
		Quantity	1
	Compressor Oil Brand		IDEMITSUKOSAN CO.,LTD
	Compressor Oil Type		PZ46M
Compressor Oil Charge(Compressor + Gas-liquid Separator)	ml	600	
Fan Motor	Brand		BROAD-OCEAN
	IP Class		IP44
	Type		DC
	Quantity		1
	Insulation Class		E
	Safe Class		I
	Max. Speed	rpm	900
Fan	Brand		Shun wei
	Type		Axial
	Diameter	mm	Ø604
Heat Exchanger	Number of Rows		2
	Tube Pitch	mm	21
	Row Pitch	mm	18.186
	Fin Spacing	mm	1.45
	Fin Type		Hydrophilic aluminum
	Fin Coating Type	Optional	Clear lacquer
	Salt Spray Test Duration	hour	168
	Tube(ID)	mm	φ7
Tube Type		INNERGROOVE TUBE	
Plate Heat Exchanger	Brand		Weyee
Water Pump	Head	m	7.5
Electronic Expansion Valve	LEVa	Brand	SANHUA
Four Way Valve	Brand		SANHUA/DANAN
	Quantity		1
Pressure Sensor of Discharge	Brand		Sensata/SANHUA
Pressure Sensor of Suction	Brand		Sensata/SANHUA
Temp. Sensor	Temperature Sensor Type		Discharge
	Value of Resistance @20°C /Ω		50K
	Temperature Sensor Type		Suction/Outdoor Ambient/Defrost/ Liquid pipe/Gas pipe/Inlet water/ Outlet water
	Value of Resistance @20°C /Ω		10K

Product Data		Unit	AW082MUGHA
Cabinet Coating	Coating Type		Powder Coating
	Salt Spray Test Duration	hour	72
	Sheet Metal Material		Hot zinc plate
	Sheet Metal Thickness	mm	1
Electrical Control Box IP Class		Standard	IP24
Refrigerant	Type	-	R290
	Charge	kg	0.90
	CO2 Eq.	kg	2.70
Net Dimension	H*W*D	mm	790*1250*380
Packing Dimension	H*W*D	mm	1022*1395*595
Net/Gross Weight		kg	106/139
Sound Pressure Level*(1)		dB(A)	48
Sound Power Level*(1)		dB	59
Power Supply		Ph/V/Hz	1/220~240/50
Minimum Circuit Amps(MCA)		A	18.6
Maximum Fuse Amps(MFA)		A	20
Minimum Power Supply Cable		mm ²	6
Accessory	Wired Controller	/	HW-WA101DBT(Standard)*1
	PCB Box	/	ATW-A03N(Standard)*1
	Filter	/	Y-type(Standard)*1
<p>Note:</p> <p>1. Accordng to EN14511, EN14825 (EU) and No 811/2013(EU).</p> <p>2. LWT: Leaving water temperature; OAT: Outdoor air temperature.</p> <p>3. Sound level values are measured in a semi-anechoic room. Sound power level values are based on measurement of EN12102-1 under conditions of EN14825.</p> <p>4. The above data may be changed without notice as a result of future improvement to quality and performance.</p>			

Product Data		Unit	AW102MUGHA
Heating (LWT 35°C / OAT 7°C)	Capacity	kW	10.00
	Power input	kW	1.96
	COP	W/W	5.10
Heating (LWT 55°C / OAT 7°C)	Capacity	kW	10.00
	Power input	kW	3.13
	COP	W/W	3.20
Space Heating Average Climate Water Outlet 35°C	SCOP	~	5.10
	η_s	%	201
	Energy class	-	A+++
Space Heating Average Climate Water Outlet 55°C	SCOP	-	3.83
	η_s	%	150
	Energy class	-	A+++
Cooling (LWT 18°C / OAT 35°C)	Capacity	kW	9.50
	Power input	kW	2.21
	EER	-	4.30
Cooling (LWT 7°C / OAT 35°C)	Capacity	kW	8.50
	Power input	kW	2.62
	EER	-	3.25
Outdoor Operating Temperature Range	Heating	°C	-25 ~35
	Cooling	°C	10 ~ 48
	DHW	°C	-25 ~43
Leaving Water Temperature Range	Heating	°C	20~80
	Cooling	°C	5~25
Storage Temperature Range(Tank)	DHW	°C	25~75
Water Flow Rate	Standard	m³/h	1.772
	Minimum	m³/h	0.660
Water Piping Connection	Inlet/Outlet	inch	R 1/R 1
Expansion Tank	Tank Volume	L	4.5
	MWP	bar	3
Safety Devices			High pressure switch, Fan driver overload protector, Overcurrent fuse, Inverter overload protector, Refrigerant separator, Safety valve, Expansion vessel
Defrost Method			4WV reverse defrosting
Casing	Color		Slate Grey
	Material		Galvanized steel

Product Data		Unit	AW102MUGHA	
Compressor	Brand		MITSUBISHI ELECTRIC	
	Type		DC Inverter Twin Rotary	
	Compressor Quantity		1	
	Rated Load Amps. (RLA)	A	7.50	
	Crankcase Heater	W		27
		Quantity		1
	Compressor Oil Brand		IDEMITSUKOSAN CO.,LTD	
	Compressor Oil Type		PZ46M	
Compressor Oil Charge(Compressor + Gas-liquid Separator)	ml		600	
Fan Motor	Brand		BROAD-OCEAN	
	IP Class		IP44	
	Type		DC	
	Quantity		1	
	Insulation Class		E	
	Safe Class		I	
	Max. Speed	rpm		900
Fan	Brand		Shun wei	
	Type		Axial	
	Diameter	mm	Ø604	
Heat Exchanger	Number of Rows		2	
	Tube Pitch	mm	21	
	Row Pitch	mm	18.186	
	Fin Spacing	mm	1.45	
	Fin Type		Hydrophilic aluminum	
	Fin Coating Type	Optional	Clear lacquer	
	Salt Spray Test Duration	hour	168	
	Tube(ID)	mm	φ7	
Tube Type		INNERGROOVE TUBE		
Plate Heat Exchanger	Brand		Weyee	
Water Pump	Head	m	7.5	
Electronic Expansion Valve	LEVa	Brand	SANHUA	
Four Way Valve	Brand		SANHUA/DANAN	
	Quantity		1	
Pressure Sensor of Discharge	Brand		Sensata/SANHUA	
Pressure Sensor of Suction	Brand		Sensata/SANHUA	

Product Data		Unit	AW102MUGHA
Temp. Sensor	Temperature Sensor Type		Discharge
	Value of Resistance @20°C /Ω		50K
	Temperature Sensor Type		Suction/Outdoor Ambient/Defrost/ Liquid pipe/Gas pipe/Inlet water/ Outlet water
	Value of Resistance @20°C /Ω		10K
Cabinet Coating	Coating Type		Powder Coating
	Salt Spray Test Duration	hour	72
	Sheet Metal Material		Hot zinc plate
	Sheet Metal Thickness	mm	1
Electrical Control Box IP Class		Standard	IP24
Refrigerant	Type	-	R290
	Charge	kg	0.90
	CO ₂ Eq.	kg	2.70
Net Dimension	H*W*D	mm	790*1250*380
Packing Dimension	H*W*D	mm	1022*1395*595
Net/Gross Weight		kg	106/139
Sound Pressure Level*(1)		dB(A)	49
Sound Power Level*(1)		dB	60
Power Supply		Ph/V/Hz	1/220~240/50
Minimum Circuit Amps(MCA)		A	18.6
Maximum Fuse Amps(MFA)		A	20
Minimum Power Supply Cable		mm ²	6
Accessory	Wired Controller	/	HW-WA101DBT(Standard)*1
	PCB Box	/	ATW-A03N(Standard)*1
	Filter	/	Y-type(Standard)*1
<p>Note:</p> <p>1. Accordng to EN14511, EN14825 (EU) and No 811/2013(EU).</p> <p>2. LWT: Leaving water temperature; OAT: Outdoor air temperature.</p> <p>3. Sound level values are measured in a semi-anechoic room. Sound power level values are based on measurement of EN12102-1 under conditions of EN14825.</p> <p>4. The above data may be changed without notice as a result of future improvement to quality and performance.</p>			

Product Data		Unit	AW122MXGHA
Heating (LWT 35°C / OAT 7°C)	Capacity	kW	12.00
	Power input	kW	2.35
	COP	W/W	5.10
Heating (LWT 55°C / OAT 7°C)	Capacity	kW	11.50
	Power input	kW	3.48
	COP	W/W	3.30
Space Heating Average Climate Water Outlet 35°C	SCOP	~	4.82
	η_s	%	190
	Energy class	-	A+++
Space Heating Average Climate Water Outlet 55°C	SCOP	-	3.85
	η_s	%	151
	Energy class	-	A+++
Cooling (LWT 18°C / OAT 35°C)	Capacity	kW	11.50
	Power input	kW	2.56
	EER	-	4.50
Cooling (LWT 7°C / OAT 35°C)	Capacity	kW	10.00
	Power input	kW	2.99
	EER	-	3.35
Outdoor Operating Temperature Range	Heating	°C	-25 ~35
	Cooling	°C	10 ~ 48
	DHW	°C	-25 ~43
Leaving Water Temperature Range	Heating	°C	20~80
	Cooling	°C	5~25
Storage Temperature Range(Tank)	DHW	°C	25~75
Water Flow Rate	Standard	m³/h	2.064
	Minimum	m³/h	0.840
Water Piping Connection	Inlet/Outlet	inch	R 1/R 1
Expansion Tank	Tank Volume	L	8
	MWP	bar	3
Safety Devices			High pressure switch, Fan driver overload protector, Overcurrent fuse, Inverter overload protector, Refrigerant separator, Safety valve, Expansion vessel
Defrost Method			4WV reverse defrosting
Casing	Color		Slate Grey
	Material		Galvanized steel

Product Data		Unit	AW122MXGHA
Compressor	Brand		MITSUBISHI ELECTRIC
	Type		DC Inverter Twin Rotary
	Compressor Quantity		1
	Rated Load Amps. (RLA)	A	10.25
	Crankcase Heater	W	27
		Quantity	1
	Compressor Oil Brand		IDEMITSUKOSAN CO.,LTD
	Compressor Oil Type		PZ46M
Fan Motor	Brand		BROAD-OCEAN
	IP Class		IP55
	Type		DC
	Quantity		1
	Insulation Class		B
	Safe Class		I
	Max. Speed	rpm	700
	Fan	Brand	
Type			Axial
Diameter		mm	Ø700
Heat Exchanger	Number of Rows		2
	Tube Pitch	mm	21
	Row Pitch	mm	18.186
	Fin Spacing	mm	1.45
	Fin Type		Hydrophilic aluminum
	Fin Coating Type	Optional	Clear lacquer
	Salt Spray Test Duration	hour	168
	Tube(ID)	mm	φ7
Tube Type		INNERGROOVE TUBE	
Plate Heat Exchanger	Brand		Weyee
Water Pump	Head	m	12.5
Electronic Expansion Valve	LEVa	Brand	SANHUA
Four Way Valve	Brand		DANAN
	Quantity		1
Pressure Sensor of Discharge	Brand		Sensata/SANHUA
Pressure Sensor of Suction	Brand		Sensata/SANHUA
Temp. Sensor	Temperature Sensor Type		Discharge
	Value of Resistance @20°C /Ω		50K
	Temperature Sensor Type		Suction/Outdoor Ambient/Defrost/ Liquid pipe/Gas pipe/Inlet water/ Outlet water
	Value of Resistance @20°C /Ω		10K

Product Data		Unit	AW122MXGHA
Cabinet Coating	Coating Type		Powder Coating
	Salt Spray Test Duration	hour	72
	Sheet Metal Material		Hot zinc plate
	Sheet Metal Thickness	mm	1
Electrical Control Box IP Class		Standard	IP24
Refrigerant	Type	-	R290
	Charge	kg	1.05
	CO ₂ Eq.	kg	3.15
Net Dimension	H*W*D	mm	880*1380*460
Packing Dimension	H*W*D	mm	1112*1526*675
Net/Gross Weight		kg	127/165
Sound Pressure Level*(1)		dB(A)	52
Sound Power Level*(1)		dB	63
Power Supply		Ph/V/Hz	1/220~240/50
Minimum Circuit Amps(MCA)		A	30.6
Maximum Fuse Amps(MFA)		A	32
Minimum Power Supply Cable		mm ²	10
Accessory	Wired Controller	/	HW-WA101DBT(Standard)*1
	PCB Box	/	ATW-A03N(Standard)*1
	Filter	/	Y-type(Standard)*1
<p>Note:</p> <p>1. Accordng to EN14511, EN14825 (EU) and No 811/2013(EU).</p> <p>2.LWT: Leaving water temperature; OAT: Outdoor air temperature.</p> <p>3.Sound level values are measured in a semi-anechoic room. Sound power level values are based on measurement of EN12102-1 under conditions of EN14825.</p> <p>4.The above data may be changed without notice as a result of future improvement to quality and performance.</p>			

Product Data		Unit	AW142MXGHA
Heating (LWT 35°C / OAT 7°C)	Capacity	kW	14.00
	Power input	kW	2.83
	COP	W/W	4.95
Heating (LWT 55°C / OAT 7°C)	Capacity	kW	13.50
	Power input	kW	4.22
	COP	W/W	3.20
Space Heating Average Climate Water Outlet 35°C	SCOP	~	4.80
	η_s	%	189
	Energy class	-	A+++
Space Heating Average Climate Water Outlet 55°C	SCOP	-	3.83
	η_s	%	150
	Energy class	-	A+++
Cooling (LWT 18°C / OAT 35°C)	Capacity	kW	13.50
	Power input	kW	3.14
	EER	-	4.30
Cooling (LWT 7°C / OAT 35°C)	Capacity	kW	12.00
	Power input	kW	3.75
	EER	-	3.20
Outdoor Operating Temperature Range	Heating	°C	-25 ~35
	Cooling	°C	10 ~ 48
	DHW	°C	-25 ~43
Leaving Water Temperature Range	Heating	°C	20~80
	Cooling	°C	5~25
Storage Temperature Range(Tank)	DHW	°C	25~75
Water Flow Rate	Standard	m³/h	0.8406
	Minimum	m³/h	0.960
Water Piping Connection	Inlet/Outlet	inch	R 1/R 1
Expansion Tank	Tank Volume	L	8
	MWP	bar	3
Safety Devices			High pressure switch, Fan driver overload protector, Overcurrent fuse, Inverter overload protector, Refrigerant separator, Safety valve, Expansion vessel
Defrost Method			4WV reverse defrosting
Casing	Color		Slate Grey
	Material		Galvanized steel

Product Data		Unit	AW142MXGHA
Compressor	Brand		MITSUBISHI ELECTRIC
	Type		DC Inverter Twin Rotary
	Compressor Quantity		1
	Rated Load Amps. (RLA)	A	10.25
	Crankcase Heater	W	28
		Quantity	1
	Compressor Oil Brand		IDEMITSUKOSAN CO.,LTD
	Compressor Oil Type		PZ46M
Compressor Oil Charge(Compressor + Gas-liquid Separator)	ml	900	
Fan Motor	Brand		BROAD-OCEAN
	IP Class		IP55
	Type		DC
	Quantity		1
	Insulation Class		B
	Safe Class		I
	Max. Speed	rpm	700
Fan	Brand		Shun wei
	Type		Axial
	Diameter	mm	Ø700
Heat Exchanger	Number of Rows		2
	Tube Pitch	mm	21
	Row Pitch	mm	18.186
	Fin Spacing	mm	1.45
	Fin Type		Hydrophilic aluminum
	Fin Coating Type	Optional	Clear lacquer
	Salt Spray Test Duration	hour	168
	Tube(ID)	mm	φ7
Tube Type		INNERGROOVE TUBE	
Plate Heat Exchanger	Brand		Weyee
Water Pump	Head	m	12.5
Electronic Expansion Valve	LEVa	Brand	SANHUA
Four Way Valve	Brand		DANAN
	Quantity		1
Pressure Sensor of Discharge	Brand		Sensata/SANHUA
Pressure Sensor of Suction	Brand		Sensata/SANHUA

Product Data		Unit	AW142MXGHA
Temp. Sensor	Temperature Sensor Type		Discharge
	Value of Resistance @20°C /Ω		50K
	Temperature Sensor Type		Suction/Outdoor Ambient/Defrost/ Liquid pipe/Gas pipe/Inlet water/ Outlet water
	Value of Resistance @20°C /Ω		10K
Cabinet Coating	Coating Type		Powder Coating
	Salt Spray Test Duration	hour	72
	Sheet Metal Material		Hot zinc plate
	Sheet Metal Thickness	mm	1
Electrical Control Box IP Class		Standard	IP24
Refrigerant	Type	-	R290
	Charge	kg	1.05
	CO ₂ Eq.	kg	3.15
Net Dimension	H*W*D	mm	880*1380*460
Packing Dimension	H*W*D	mm	1112*1526*675
Net/Gross Weight		kg	127/165
Sound Pressure Level*(1)		dB(A)	53
Sound Power Level*(1)		dB	64
Power Supply		Ph/V/Hz	1/220~240/50
Minimum Circuit Amps(MCA)		A	30.6
Maximum Fuse Amps(MFA)		A	32
Minimum Power Supply Cable		mm ²	10
Accessory	Wired Controller	/	HW-WA101DBT(Standard)*1
	PCB Box	/	ATW-A03N(Standard)*1
	Filter	/	Y-type(Standard)*1
<p>Note:</p> <p>1. Accordng to EN14511, EN14825 (EU) and No 811/2013(EU).</p> <p>2. LWT: Leaving water temperature; OAT: Outdoor air temperature.</p> <p>3. Sound level values are measured at a semi-anechoic room. And the sound power level values are based on measurement of EN12102-1 under conditions of EN14825.</p> <p>4. The above data may be changed without notice for future improvement on quality and performance.</p>			

Product Data		Unit	AW162MXGHA
Heating (LWT 35°C / OAT 7°C)	Capacity	kW	16.00
	Power input	kW	3.23
	COP	W/W	4.95
Heating (LWT 55°C / OAT 7°C)	Capacity	kW	15.50
	Power input	kW	5.08
	COP	W/W	3.05
Space Heating Average Climate Water Outlet 35°C	SCOP	~	4.80
	η_s	%	189
	Energy class	-	A+++
Space Heating Average Climate Water Outlet 55°C	SCOP	-	3.85
	η_s	%	151
	Energy class	-	A+++
Cooling (LWT 18°C / OAT 35°C)	Capacity	kW	15.50
	Power input	kW	3.88
	EER	-	4.00
Cooling (LWT 7°C / OAT 35°C)	Capacity	kW	14.00
	Power input	kW	4.52
	EER	-	3.10
Outdoor Operating Temperature Range	Heating	°C	-25 ~35
	Cooling	°C	10 ~ 48
	DHW	°C	-25 ~43
Leaving Water Temperature Range	Heating	°C	20~80
	Cooling	°C	5~25
Storage Temperature Range(Tank)	DHW	°C	25~75
Water Flow Rate	Standard	m³/h	2.754
	Minimum	m³/h	1.080
Water Piping Connection	Inlet/Outlet	inch	R 1/R 1
Expansion Tank	Tank Volume	L	8
	MWP	bar	3
Safety Devices			High pressure switch, Fan driver overload protector, Overcurrent fuse, Inverter overload protector, Refrigerant separator, Safety valve, Expansion vessel
Defrost Method			4WV reverse defrosting
Casing	Color		Slate Grey
	Material		Galvanized steel

Product Data		Unit	AW162MXGHA	
Compressor	Brand		MITSUBISHI ELECTRIC	
	Type		DC Inverter Twin Rotary	
	Compressor Quantity		1	
	Rated Load Amps. (RLA)	A	12.50	
	Crankcase Heater	W		28
		Quantity		1
	Compressor Oil Brand		IDEMITSUKOSAN CO.,LTD	
	Compressor Oil Type		PZ46M	
Fan Motor	Compressor Oil Charge(Compressor + Gas-liquid Separator)	ml	900	
	Brand		BROAD-OCEAN	
	IP Class		IP55	
	Type		DC	
	Quantity		1	
	Insulation Class		B	
	Safe Class		I	
	Max. Speed	rpm	700	
Fan	Brand		Shun wei	
	Type		Axial	
	Diameter	mm	Ø700	
Heat Exchanger	Number of Rows		3	
	Tube Pitch	mm	21	
	Row Pitch	mm	18.186	
	Fin Spacing	mm	1.45	
	Fin Type		Hydrophilic aluminum	
	Fin Coating Type	Optional	Clear lacquer	
	Salt Spray Test Duration	hour	168	
	Tube(ID)	mm	φ7	
Tube Type		INNERGROOVE TUBE		
Plate Heat Exchanger	Brand		Weyee	
Water Pump	Head	m	12.5	
Electronic Expansion Valve	LEVa	Brand	SANHUA	
Four Way Valve		Brand	DANAN	
		Quantity	1	
Pressure Sensor of Discharge	Brand		Sensata/SANHUA	
Pressure Sensor of Suction	Brand		Sensata/SANHUA	
Temp. Sensor	Temperature Sensor Type		Discharge	
	Value of Resistance @20°C /Ω		50K	
	Temperature Sensor Type		Suction/Outdoor Ambient/Defrost/ Liquid pipe/Gas pipe/Inlet water/ Outlet water	
	Value of Resistance @20°C /Ω		10K	

Product Data		Unit	AW162MXGHA
Cabinet Coating	Coating Type		Powder Coating
	Salt Spray Test Duration	hour	72
	Sheet Metal Material		Hot zinc plate
	Sheet Metal Thickness	mm	1
Electrical Control Box IP Class		Standard	IP24
Refrigerant	Type	-	R290
	Charge	kg	1.25
	CO ₂ Eq.	kg	3.75
Net Dimension	H*W*D	mm	880*1380*460
Packing Dimension	H*W*D	mm	1112*1526*675
Net/Gross Weight		kg	136/174
Sound Pressure Level*(1)		dB(A)	55
Sound Power Level*(1)		dB	66
Power Supply		Ph/V/Hz	1/220~240/50
Minimum Circuit Amps(MCA)		A	34.8
Maximum Fuse Amps(MFA)		A	40
Minimum Power Supply Cable		mm ²	10
Accessory	Wired Controller	/	HW-WA101DBT(Standard)*1
	PCB Box	/	ATW-A03N(Standard)*1
	Filter	/	Y-type(Standard)*1
<p>Note:</p> <p>1. Accordng to EN14511, EN14825 (EU) and No 811/2013(EU).</p> <p>2. LWT: Leaving water temperature; OAT: Outdoor air temperature.</p> <p>3. Sound level values are measured in a semi-anechoic room. Sound power level values are based on measurement of EN12102-1 under conditions of EN14825.</p> <p>4. The above data may be changed without notice as a result of future improvement to quality and performance.</p>			

Product Data		Unit	AW10NMUGHA
Heating (LWT 35°C / OAT 7°C)	Capacity	kW	10.00
	Power input	kW	1.96
	COP	W/W	5.10
Heating (LWT 55°C / OAT 7°C)	Capacity	kW	10.00
	Power input	kW	3.13
	COP	W/W	3.20
Space Heating Average Climate Water Outlet 35°C	SCOP	~	5.10
	η_s	%	201
	Energy class	-	A+++
Space Heating Average Climate Water Outlet 55°C	SCOP	-	3.83
	η_s	%	150
	Energy class	-	A+++
Cooling (LWT 18°C / OAT 35°C)	Capacity	kW	9.50
	Power input	kW	2.21
	EER	-	4.30
Cooling (LWT 7°C / OAT 35°C)	Capacity	kW	8.50
	Power input	kW	2.62
	EER	-	3.25
Outdoor Operating Temperature Range	Heating	°C	-25 ~35
	Cooling	°C	10 ~ 48
	DHW	°C	-25 ~43
Leaving Water Temperature Range	Heating	°C	20~80
	Cooling	°C	5~25
Storage Temperature Range(Tank)	DHW	°C	25~75
Water Flow Rate	Standard	m³/h	1.722
	Minimum	m³/h	0.660
Water Piping Connection	Inlet/Outlet	inch	R 1/R 1
Expansion Tank	Tank Volume	L	4.5
	MWP	bar	3
Safety Devices			High pressure switch, Fan driver overload protector, Overcurrent fuse, Inverter overload protector, Refrigerant separator, Safety valve, Expansion vessel
Defrost Method			4WV reverse defrosting
Casing	Color		Slate Grey
	Material		Galvanized steel

Product Data		Unit	AW10NMUGHA	
Compressor	Brand		MITSUBISHI ELECTRIC	
	Type		DC Inverter Twin Rotary	
	Compressor Quantity		1	
	Rated Load Amps. (RLA)	A	7.50	
	Crankcase Heater	W		27
		Quantity		1
	Compressor Oil Brand		IDEMITSUKOSAN CO.,LTD	
	Compressor Oil Type		PZ46M	
Compressor Oil Charge(Compressor + Gas-liquid Separator)	ml		600	
Fan Motor	Brand		BROAD-OCEAN	
	IP Class		IP44	
	Type		DC	
	Quantity		1	
	Insulation Class		E	
	Safe Class		I	
	Max. Speed	rpm		900
Fan	Brand		Shun wei	
	Type		Axial	
	Diameter	mm	Ø604	
Heat Exchanger	Number of Rows		2	
	Tube Pitch	mm	21	
	Row Pitch	mm	18.186	
	Fin Spacing	mm	1.45	
	Fin Type		Hydrophilic aluminum	
	Fin Coating Type	Optional		Clear lacquer
	Salt Spray Test Duration	hour		168
	Tube(ID)	mm		φ7
Tube Type			INNERGROOVE TUBE	
Plate Heat Exchanger	Brand		Weyee	
Water Pump	Head	m	7.5	
Electronic Expansion Valve	LEVa	Brand	SANHUA	
Four Way Valve		Brand	DANAN	
		Quantity	1	
Pressure Sensor of Discharge	Brand		Sensata/SANHUA	
Pressure Sensor of Suction	Brand		Sensata/SANHUA	

Product Data		Unit	AW10NMUGHA
Temp. Sensor	Temperature Sensor Type		Discharge
	Value of Resistance @20°C /Ω		50K
	Temperature Sensor Type		Suction/Outdoor Ambient/Defrost/ Liquid pipe/Gas pipe/Inlet water/ Outlet water
	Value of Resistance @20°C /Ω		10K
Cabinet Coating	Coating Type		Powder Coating
	Salt Spray Test Duration	hour	72
	Sheet Metal Material		Hot zinc plate
	Sheet Metal Thickness	mm	1
Electrical Control Box IP Class		Standard	IP24
Refrigerant	Type	-	R290
	Charge	kg	0.90
	CO ₂ Eq.	kg	2.70
Net Dimension	H*W*D	mm	790*1250*380
Packing Dimension	H*W*D	mm	1022*1395*595
Net/Gross Weight		kg	121/154
Sound Pressure Level*(1)		dB(A)	49
Sound Power Level*(1)		dB	60
Power Supply		Ph/V/Hz	3/380~415/50
Minimum Circuit Amps(MCA)		A	6.2
Maximum Fuse Amps(MFA)		A	16
Minimum Power Supply Cable		mm ²	4
Accessory	Wired Controller	/	HW-WA101DBT(Standard)*1
	PCB Box	/	ATW-A03N(Standard)*1
	Filter	/	Y-type(Standard)*1
<p>Note:</p> <p>1. Accordng to EN14511, EN14825 (EU) and No 811/2013(EU).</p> <p>2. LWT: Leaving water temperature; OAT: Outdoor air temperature.</p> <p>3. Sound level values are measured in a semi-anechoic room. Sound power level values are based on measurement of EN12102-1 under conditions of EN14825.</p> <p>4. The above data may be changed without notice as a result of future improvement to quality and performance.</p>			

Product Data		Unit	AW12NMXGHA
Heating (LWT 35°C / OAT 7°C)	Capacity	kW	12.00
	Power input	kW	2.35
	COP	W/W	5.10
Heating (LWT 55°C / OAT 7°C)	Capacity	kW	11.50
	Power input	kW	3.48
	COP	W/W	3.30
Space Heating Average Climate Water Outlet 35°C	SCOP	~	4.82
	η_s	%	190
	Energy class	-	A+++
Space Heating Average Climate Water Outlet 55°C	SCOP	-	3.85
	η_s	%	151
	Energy class	-	A+++
Cooling (LWT 18°C / OAT 35°C)	Capacity	kW	11.50
	Power input	kW	2.56
	EER	-	4.50
Cooling (LWT 7°C / OAT 35°C)	Capacity	kW	10.00
	Power input	kW	2.99
	EER	-	3.35
Outdoor Operating Temperature Range	Heating	°C	-25 ~35
	Cooling	°C	10 ~ 48
	DHW	°C	-25 ~43
Leaving Water Temperature Range	Heating	°C	20~80
	Cooling	°C	5~25
Storage Temperature Range(Tank)	DHW	°C	25~75
Water Flow Rate	Standard	m³/h	2.064
	Minimum	m³/h	0.840
Water Piping Connection	Inlet/Outlet	inch	R 1/R 1
Expansion Tank	Tank Volume	L	8
	MWP	bar	3
Safety Devices			High pressure switch, Fan driver overload protector, Overcurrent fuse, Inverter overload protector, Refrigerant separator, Safety valve, Expansion vessel
Defrost Method			4WV reverse defrosting
Casing	Color		Slate Grey
	Material		Galvanized steel

Product Data		Unit	AW12NMXGHA
Compressor	Brand		MITSUBISHI ELECTRIC
	Type		DC Inverter Twin Rotary
	Compressor Quantity		1
	Rated Load Amps. (RLA)	A	10.25
	Crankcase Heater	W	27
		Quantity	1
	Compressor Oil Brand		IDEMITSUKOSAN CO.,LTD
	Compressor Oil Type		PZ46M
Fan Motor	Brand		BROAD-OCEAN
	IP Class		IP55
	Type		DC
	Quantity		1
	Insulation Class		B
	Safe Class		I
	Max. Speed	rpm	700
	Fan	Brand	
Type			Axial
Diameter		mm	Ø700
Heat Exchanger	Number of Rows		2
	Tube Pitch	mm	21
	Row Pitch	mm	18.186
	Fin Spacing	mm	1.45
	Fin Type		Hydrophilic aluminum
	Fin Coating Type	Optional	Clear lacquer
	Salt Spray Test Duration	hour	168
	Tube(ID)	mm	φ7
Tube Type		INNERGROOVE TUBE	
Plate Heat Exchanger	Brand		Weyee
Water Pump	Head	m	12.5
Electronic Expansion Valve	LEVa	Brand	SANHUA
Four Way Valve	Brand		DANAN
	Quantity		1
Pressure Sensor of Discharge	Brand		Sensata/SANHUA
Pressure Sensor of Suction	Brand		Sensata/SANHUA

Product Data		Unit	AW12NMXGHA
Temp. Sensor	Temperature Sensor Type		Discharge
	Value of Resistance @20°C /Ω		50K
	Temperature Sensor Type		Suction/Outdoor Ambient/Defrost/ Liquid pipe/Gas pipe/Inlet water/ Outlet water
	Value of Resistance @20°C /Ω		10K
Cabinet Coating	Coating Type		Powder Coating
	Salt Spray Test Duration	hour	72
	Sheet Metal Material		Hot zinc plate
	Sheet Metal Thickness	mm	1
Electrical Control Box IP Class		Standard	IP24
Refrigerant	Type	-	R290
	Charge	kg	1.05
	CO ₂ Eq.	kg	3.15
Net Dimension	H*W*D	mm	880*1380*460
Packing Dimension	H*W*D	mm	1112*1526*675
Net/Gross Weight		kg	142/180
Sound Pressure Level*(1)		dB(A)	52
Sound Power Level*(1)		dB	63
Power Supply		Ph/V/Hz	3/380~415/50
Minimum Circuit Amps(MCA)		A	10.2
Maximum Fuse Amps(MFA)		A	16
Minimum Power Supply Cable		mm ²	4
Accessory	Wired Controller	/	HW-WA101DBT(Standard)*1
	PCB Box	/	ATW-A03N(Standard)*1
	Filter	/	Y-type(Standard)*1
<p>Note:</p> <p>1.Accordng to EN14511, EN14825 (EU) and No 811/2013(EU).</p> <p>2.LWT: Leaving water temperature; OAT: Outdoor air temperature.</p> <p>3.Sound level values are measured in a semi-anechoic room. Sound power level values are based on measurement of EN12102-1 under conditions of EN14825.</p> <p>4.The above data may be changed without notice as a result of future improvement to quality and performance.</p>			

Product Data		Unit	AW14NMXGHA
Heating (LWT 35°C / OAT 7°C)	Capacity	kW	14.00
	Power input	kW	2.83
	COP	W/W	4.95
Heating (LWT 55°C / OAT 7°C)	Capacity	kW	13.50
	Power input	kW	4.22
	COP	W/W	3.20
Space Heating Average Climate Water Outlet 35°C	SCOP	~	4.80
	η_s	%	189
	Energy class	-	A+++
Space Heating Average Climate Water Outlet 55°C	SCOP	-	3.83
	η_s	%	150
	Energy class	-	A+++
Cooling (LWT 18°C / OAT 35°C)	Capacity	kW	13.50
	Power input	kW	3.14
	EER	-	4.30
Cooling (LWT 7°C / OAT 35°C)	Capacity	kW	12.00
	Power input	kW	3.75
	EER	-	3.20
Outdoor Operating Temperature Range	Heating	°C	-25 ~35
	Cooling	°C	10 ~ 48
	DHW	°C	-25 ~43
Leaving Water Temperature Range	Heating	°C	20~80
	Cooling	°C	5~25
Storage Temperature Range(Tank)	DHW	°C	25~75
Water Flow Rate	Standard	m³/h	2.406
	Minimum	m³/h	0.960
Water Piping Connection	Inlet/Outlet	inch	R 1/R 1
Expansion Tank	Tank Volume	L	8
	MWP	bar	3
Safety Devices			High pressure switch, Fan driver overload protector, Overcurrent fuse, Inverter overload protector, Refrigerant separator, Safety valve, Expansion vessel
Defrost Method			4WV reverse defrosting
Casing	Color		Slate Grey
	Material		Galvanized steel

Product Data		Unit	AW14NMXGHA	
Compressor	Brand		MITSUBISHI ELECTRIC	
	Type		DC Inverter Twin Rotary	
	Compressor Quantity		1	
	Rated Load Amps. (RLA)	A	10.25	
	Crankcase Heater	W		28
		Quantity		1
	Compressor Oil Brand		IDEMITSUKOSAN CO.,LTD	
	Compressor Oil Type		PZ46M	
Compressor Oil Charge(Compressor + Gas-liquid Separator)	ml		900	
Fan Motor	Brand		BROAD-OCEAN	
	IP Class		IP55	
	Type		DC	
	Quantity		1	
	Insulation Class		B	
	Safe Class		I	
	Max. Speed	rpm		700
Fan	Brand		Shun wei	
	Type		Axial	
	Diameter	mm	Ø700	
Heat Exchanger	Number of Rows		2	
	Tube Pitch	mm	21	
	Row Pitch	mm	18.186	
	Fin Spacing	mm	1.45	
	Fin Type		Hydrophilic aluminum	
	Fin Coating Type	Optional		Clear lacquer
	Salt Spray Test Duration	hour		168
	Tube(ID)	mm		φ7
Tube Type			INNERGROOVE TUBE	
Plate Heat Exchanger	Brand		Weyee	
Water Pump	Head	m	12.5	
Electronic Expansion Valve	LEVa	Brand	SANHUA	
Four Way Valve	Brand		DANAN	
	Quantity		1	
Pressure Sensor of Discharge	Brand		Sensata/SANHUA	
Pressure Sensor of Suction	Brand		Sensata/SANHUA	

Product Data		Unit	AW14NMXGHA
Temp. Sensor	Temperature Sensor Type		Discharge
	Value of Resistance @20°C /Ω		50K
	Temperature Sensor Type		Suction/Outdoor Ambient/Defrost/ Liquid pipe/Gas pipe/Inlet water/ Outlet water
	Value of Resistance @20°C /Ω		10K
Cabinet Coating	Coating Type		Powder Coating
	Salt Spray Test Duration	hour	72
	Sheet Metal Material		Hot zinc plate
	Sheet Metal Thickness	mm	1
Electrical Control Box IP Class		Standard	IP24
Refrigerant	Type	-	R290
	Charge	kg	1.05
	CO ₂ Eq.	kg	3.15
Net Dimension	H*W*D	mm	880*1380*460
Packing Dimension	H*W*D	mm	1112*1526*675
Net/Gross Weight		kg	142/180
Sound Pressure Level*(1)		dB(A)	53
Sound Power Level*(1)		dB	64
Power Supply		Ph/V/Hz	3/380~415/50
Minimum Circuit Amps(MCA)		A	10.2
Maximum Fuse Amps(MFA)		A	16
Minimum Power Supply Cable		mm ²	4
Accessory	Wired Controller	/	HW-WA101DBT(Standard)*1
	PCB Box	/	ATW-A03N(Standard)*1
	Filter	/	Y-type(Standard)*1
<p>Note:</p> <p>1. Accordng to EN14511, EN14825 (EU) and No 811/2013(EU).</p> <p>2. LWT: Leaving water temperature; OAT: Outdoor air temperature.</p> <p>3. Sound level values are measured in a semi-anechoic room. Sound power level values are based on measurement of EN12102-1 under conditions of EN14825.</p> <p>4. The above data may be changed without notice as a result of future improvement to quality and performance.</p>			

Product Data		Unit	AW16NMXGHA
Heating (LWT 35°C / OAT 7°C)	Capacity	kW	16.00
	Power input	kW	3.23
	COP	W/W	4.95
Heating (LWT 55°C / OAT 7°C)	Capacity	kW	15.50
	Power input	kW	5.08
	COP	W/W	3.05
Space Heating Average Climate Water Outlet 35°C	SCOP	~	4.80
	η_s	%	189
	Energy class	-	A+++
Space Heating Average Climate Water Outlet 55°C	SCOP	-	3.85
	η_s	%	151
	Energy class	-	A+++
Cooling (LWT 18°C / OAT 35°C)	Capacity	kW	15.50
	Power input	kW	3.88
	EER	-	4.00
Cooling (LWT 7°C / OAT 35°C)	Capacity	kW	14.00
	Power input	kW	4.52
	EER	-	3.10
Outdoor Operating Temperature Range	Heating	°C	-25 ~35
	Cooling	°C	10 ~ 48
	DHW	°C	-25 ~43
Leaving Water Temperature Range	Heating	°C	20~80
	Cooling	°C	5~25
Storage Temperature Range(Tank)	DHW	°C	25~75
Water Flow Rate	Standard	m³/h	2.754
	Minimum	m³/h	1.080
Water Piping Connection	Inlet/Outlet	inch	R 1/R 1
Expansion Tank	Tank Volume	L	8
	MWP	bar	3
Safety Devices			High pressure switch, Fan driver overload protector, Overcurrent fuse, Inverter overload protector, Refrigerant separator, Safety valve, Expansion vessel
Defrost Method			4WV reverse defrosting
Casing	Color		Slate Grey
	Material		Galvanized steel

Product Data		Unit	AW16NMXGHA	
Compressor	Brand		MITSUBISHI ELECTRIC	
	Type		DC Inverter Twin Rotary	
	Compressor Quantity		1	
	Rated Load Amps. (RLA)	A	12.50	
	Crankcase Heater	W		28
		Quantity		1
	Compressor Oil Brand		IDEMITSUKOSAN CO.,LTD	
	Compressor Oil Type		PZ46M	
Fan Motor	Compressor Oil Charge(Compressor + Gas-liquid Separator)	ml	900	
	Brand		BROAD-OCEAN	
	IP Class		IP55	
	Type		DC	
	Quantity		1	
	Insulation Class		B	
	Safe Class		I	
	Max. Speed	rpm	700	
Fan	Brand		Shun wei	
	Type		Axial	
	Diameter	mm	Ø700	
Heat Exchanger	Number of Rows		3	
	Tube Pitch	mm	21	
	Row Pitch	mm	18.186	
	Fin Spacing	mm	1.45	
	Fin Type		Hydrophilic aluminum	
	Fin Coating Type	Optional	Clear lacquer	
	Salt Spray Test Duration	hour	168	
	Tube(ID)	mm	φ7	
Tube Type		INNERGROOVE TUBE		
Plate Heat Exchanger	Brand		Weyee	
Water Pump	Head	m	12.5	
Electronic Expansion Valve	LEVa	Brand	SANHUA	
Four Way Valve		Brand	DANAN	
		Quantity	1	
Pressure Sensor of Discharge	Brand		Sensata/SANHUA	
Pressure Sensor of Suction	Brand		Sensata/SANHUA	
Temp. Sensor	Temperature Sensor Type		Discharge	
	Value of Resistance @20°C /Ω		50K	
	Temperature Sensor Type		Suction/Outdoor Ambient/Defrost/ Liquid pipe/Gas pipe/Inlet water/ Outlet water	
	Value of Resistance @20°C /Ω		10K	

Product Data		Unit	AW16NMXGHA
Cabinet Coating	Coating Type		Powder Coating
	Salt Spray Test Duration	hour	72
	Sheet Metal Material		Hot zinc plate
	Sheet Metal Thickness	mm	1
Electrical Control Box IP Class		Standard	IP24
Refrigerant	Type	-	R290
	Charge	kg	1.25
	CO2 Eq.	kg	3.75
Net Dimension	H*W*D	mm	880*1380*460
Packing Dimension	H*W*D	mm	1112*1526*675
Net/Gross Weight		kg	151/189
Sound Pressure Level*(1)		dB(A)	55
Sound Power Level*(1)		dB	66
Power Supply		Ph/V/Hz	3/380~415/50
Minimum Circuit Amps(MCA)		A	11.6
Maximum Fuse Amps(MFA)		A	16
Minimum Power Supply Cable		mm ²	4
Accessory	Wired Controller	/	HW-WA101DBT(Standard)*1
	PCB Box	/	ATW-A03N(Standard)*1
	Filter	/	Y-type(Standard)*1
<p>Note:</p> <p>1. Accordng to EN14511, EN14825 (EU) and No 811/2013(EU).</p> <p>2. LWT: Leaving water temperature; OAT: Outdoor air temperature.</p> <p>3. Sound level values are measured in a semi-anechoic room. Sound power level values are based on measurement of EN12102-1 under conditions of EN14825.</p> <p>4. The above data may be changed without notice as a result of future improvement to quality and performance.</p>			

5. Dimensions

AW042MUGHA AW062MUGHA AW082MUGHA AW102MUGHA AW10NMUGHA

Unit: mm

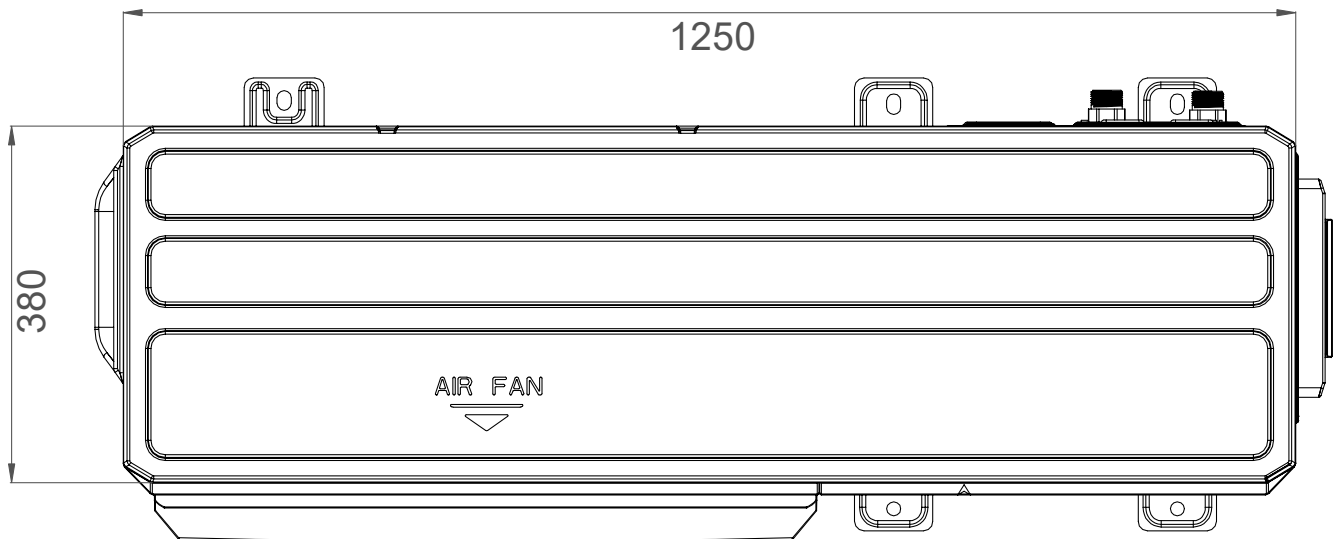
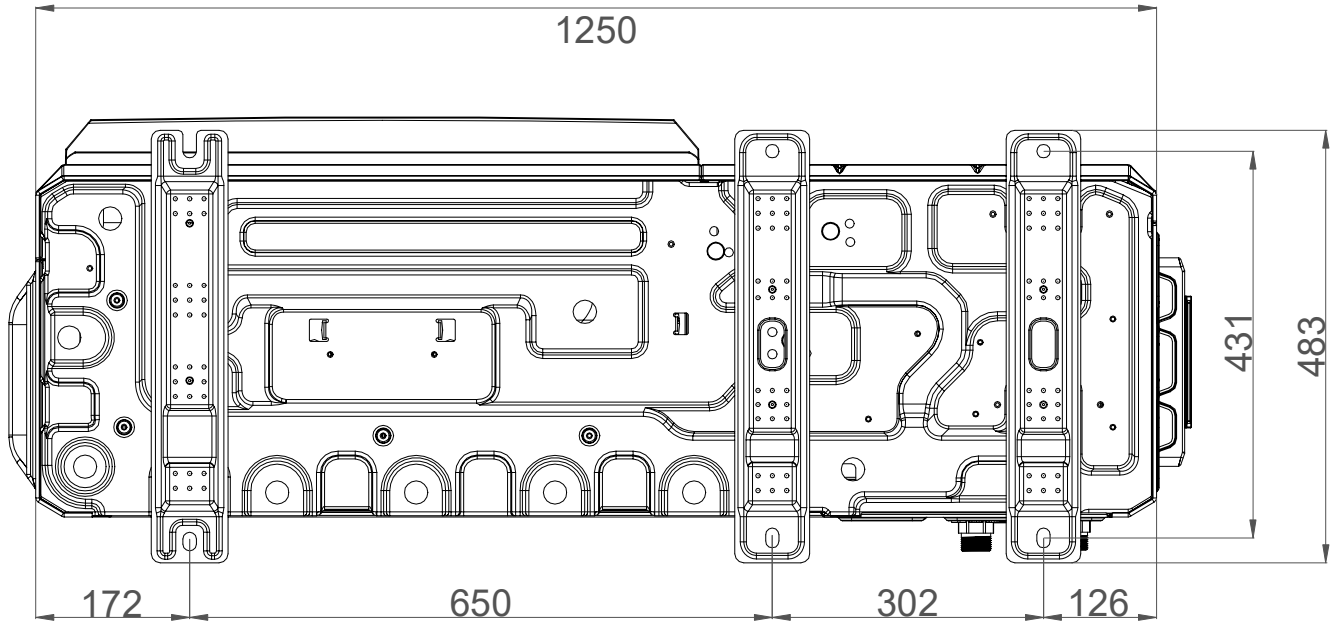

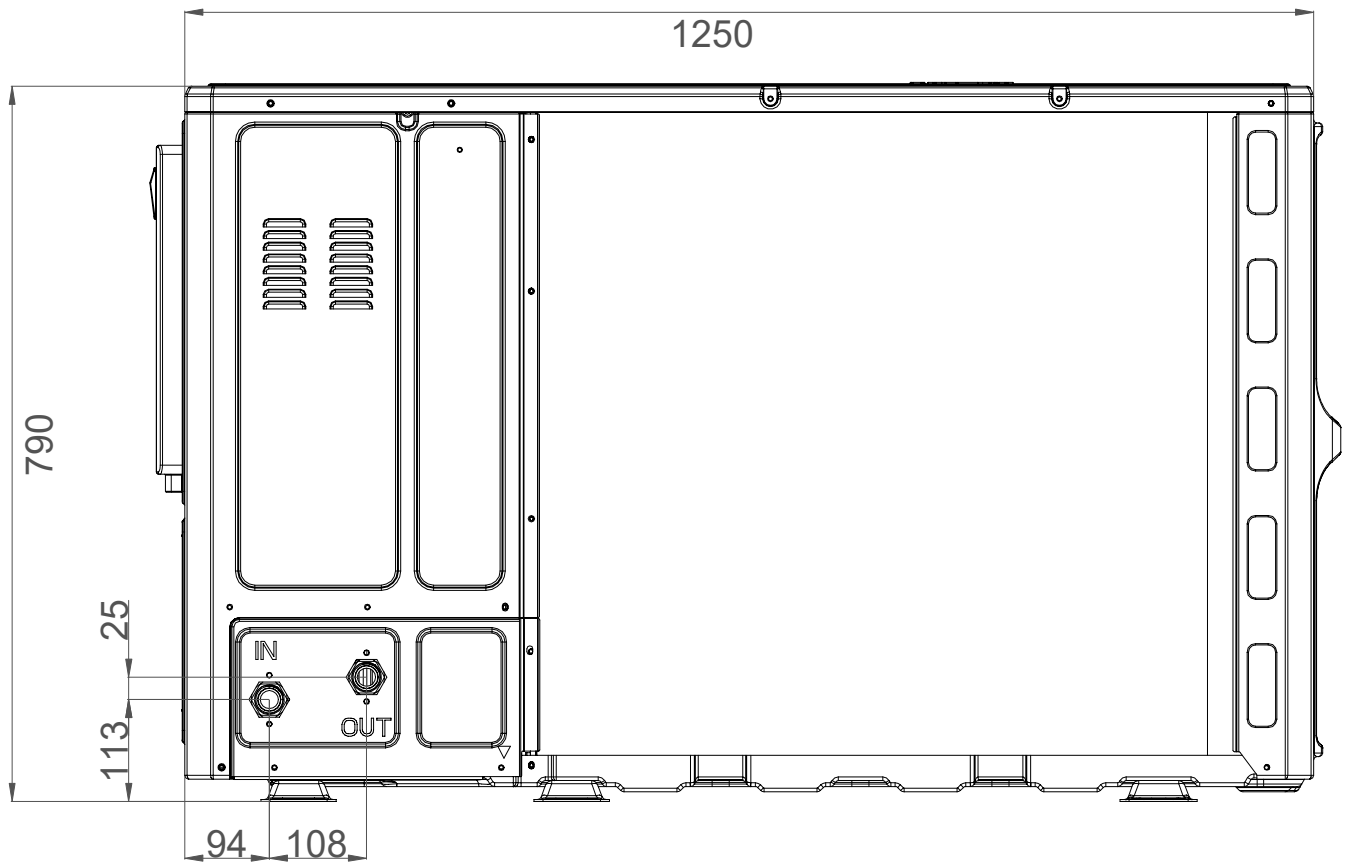
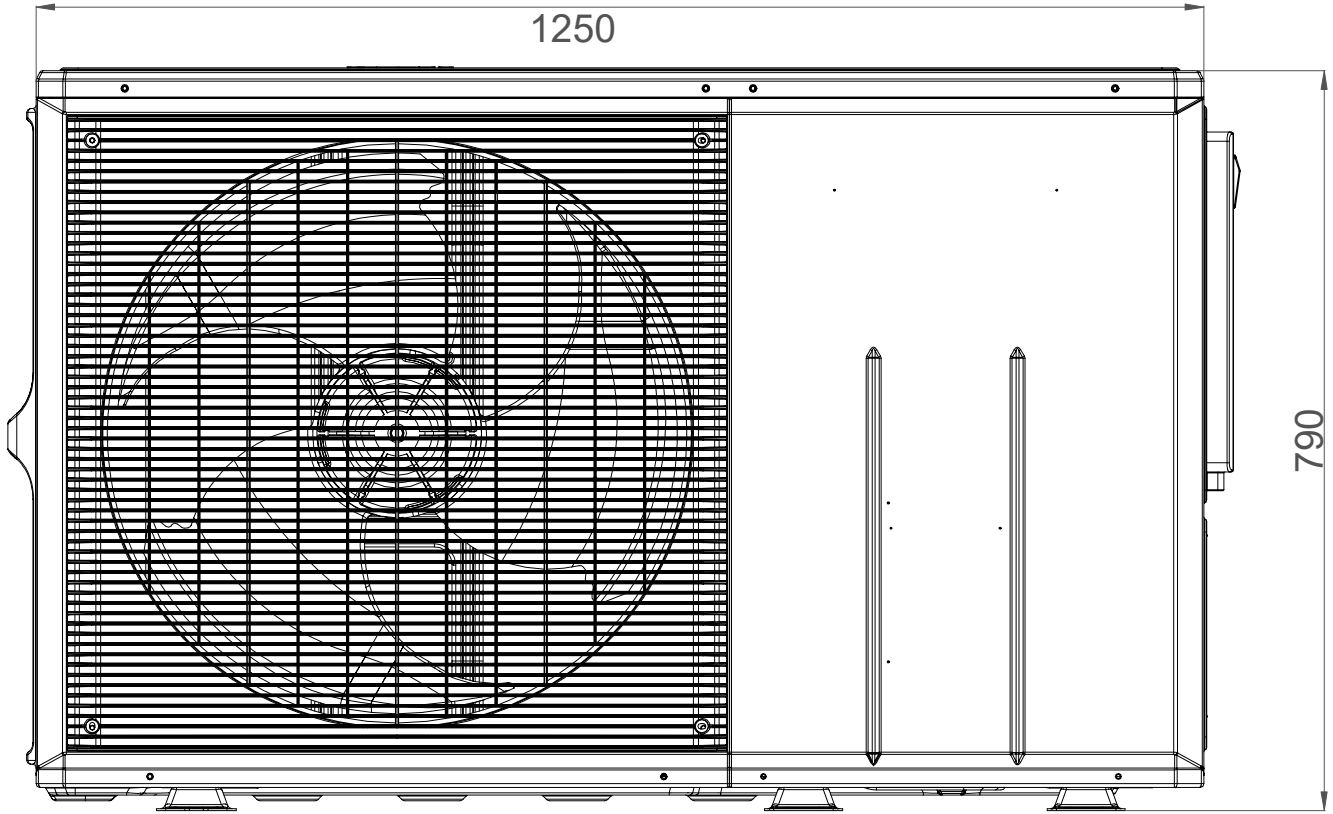

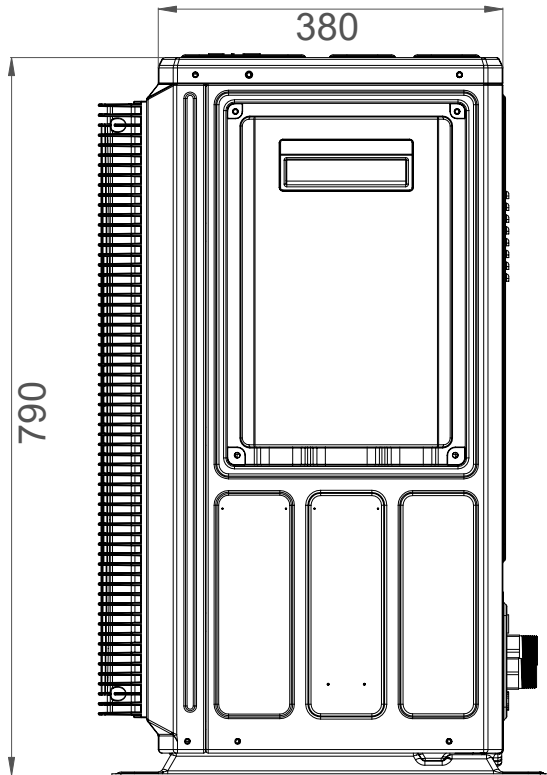

AW122MXGHA AW142MXGHA AW162MXGHA
AW12NMXGHA AW14NMXGHA AW16NMXGHA

Unit: mm

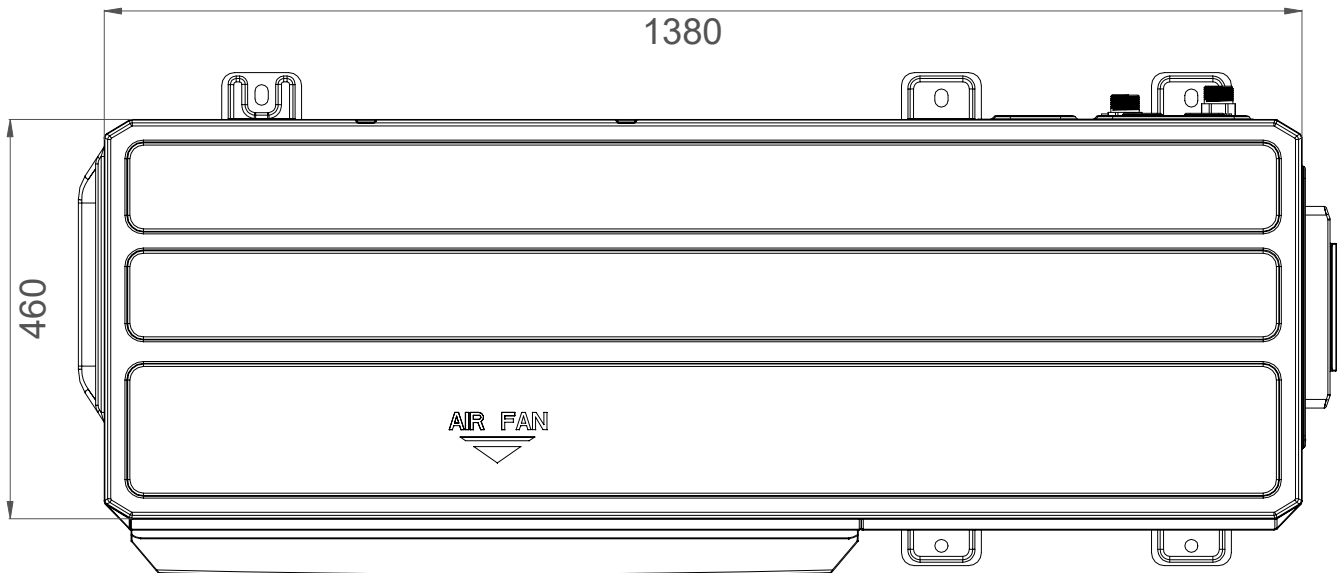
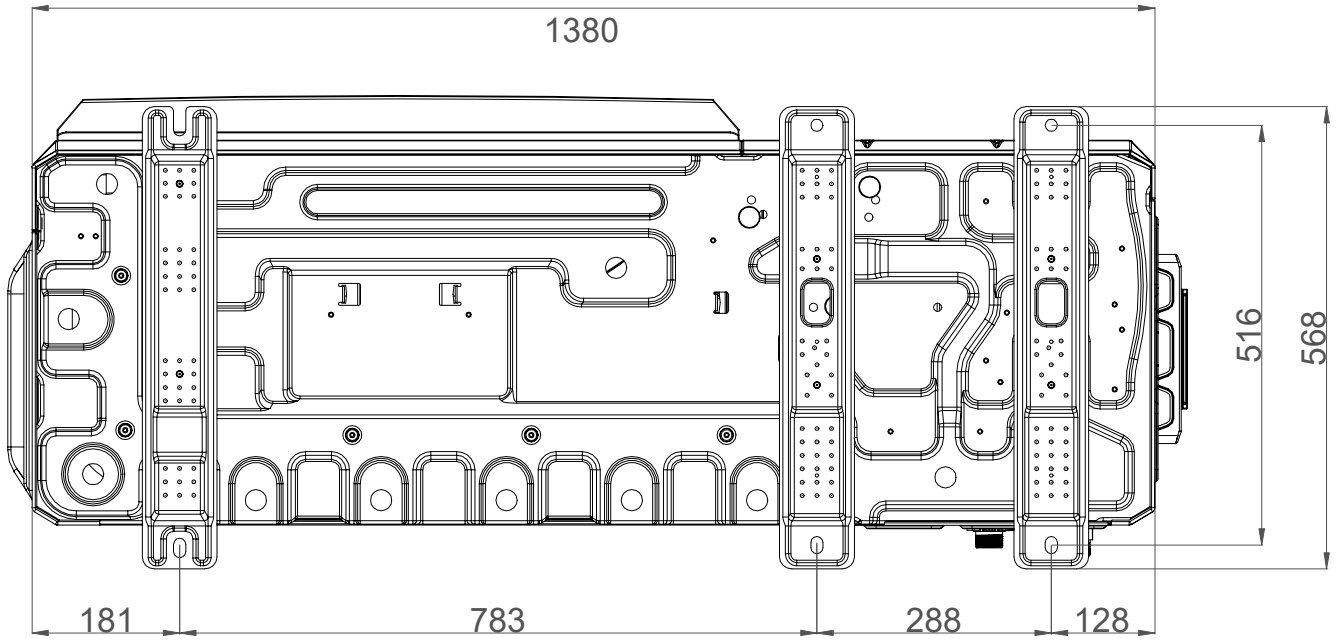

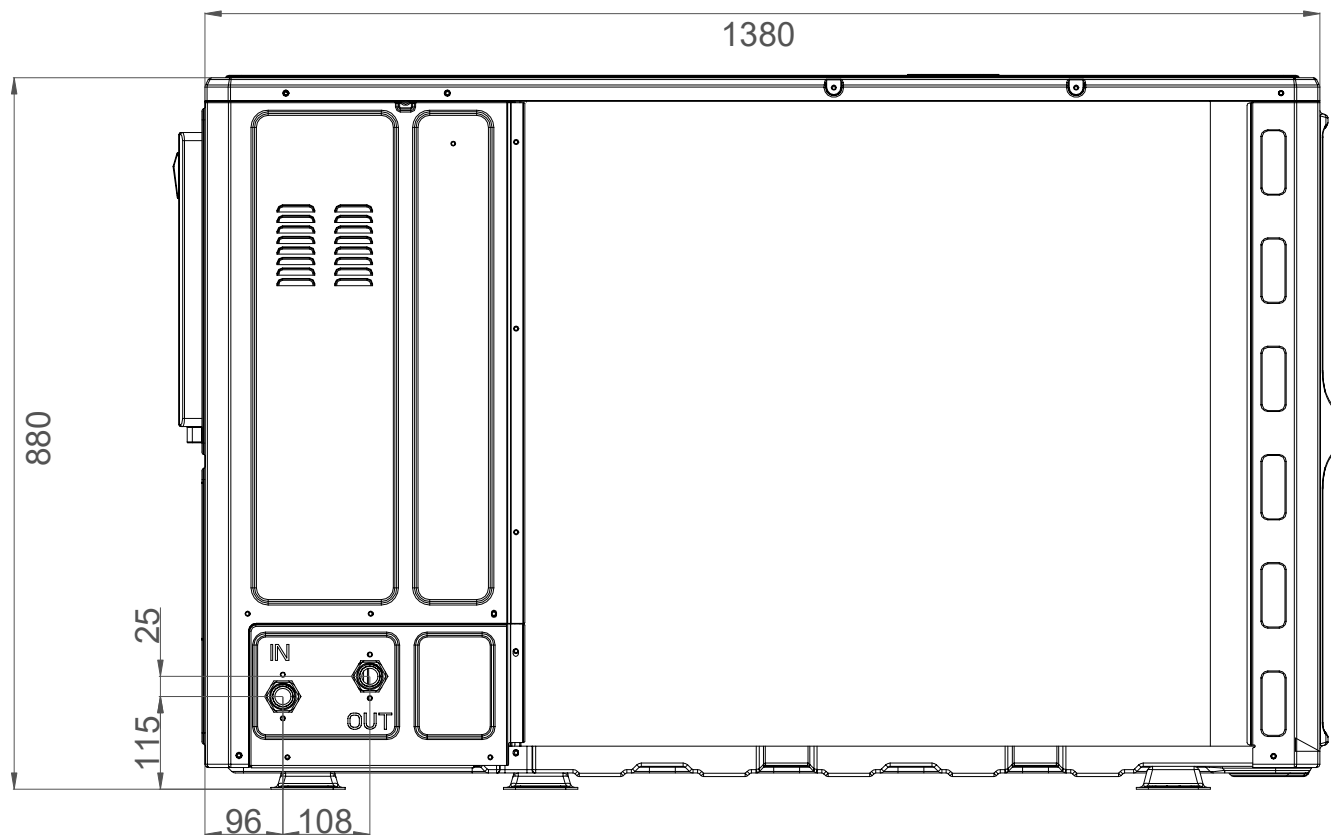
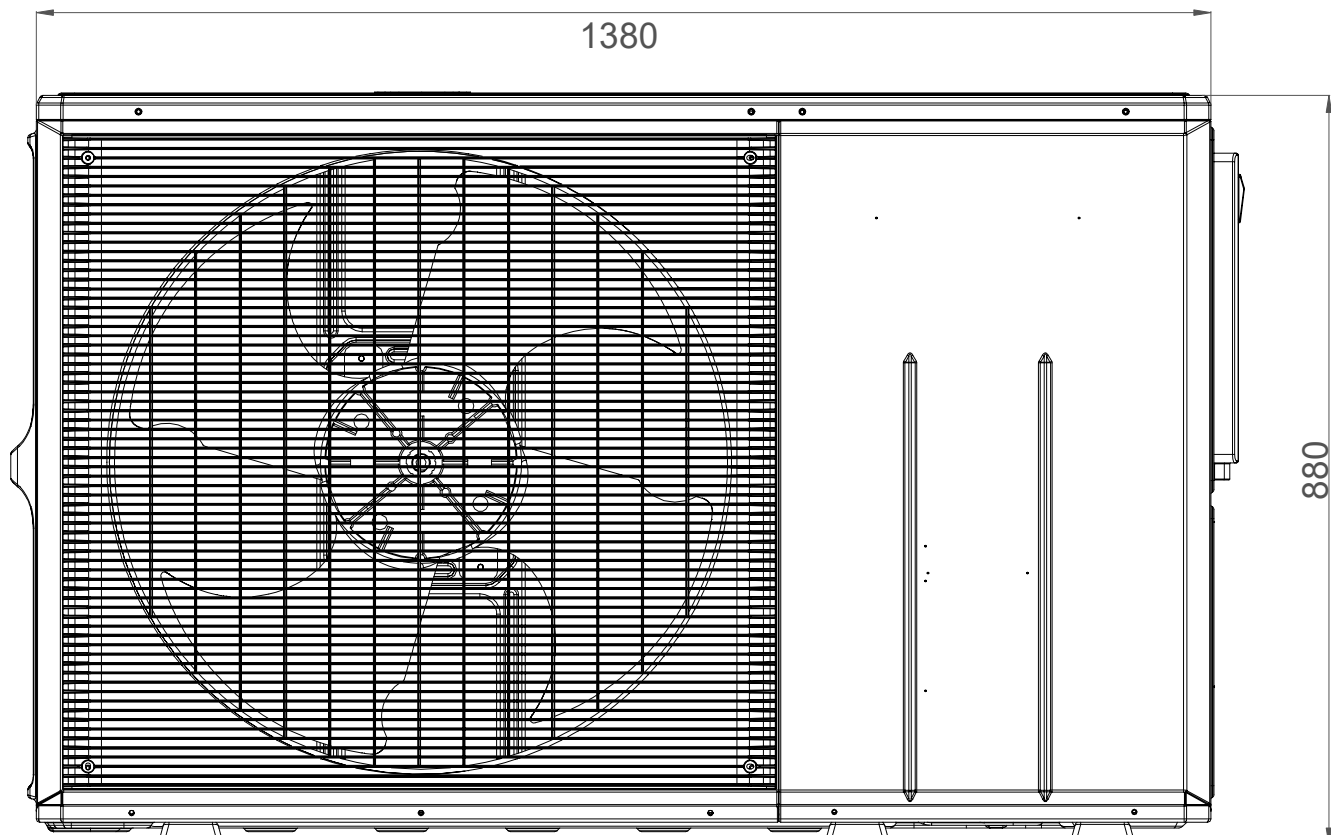

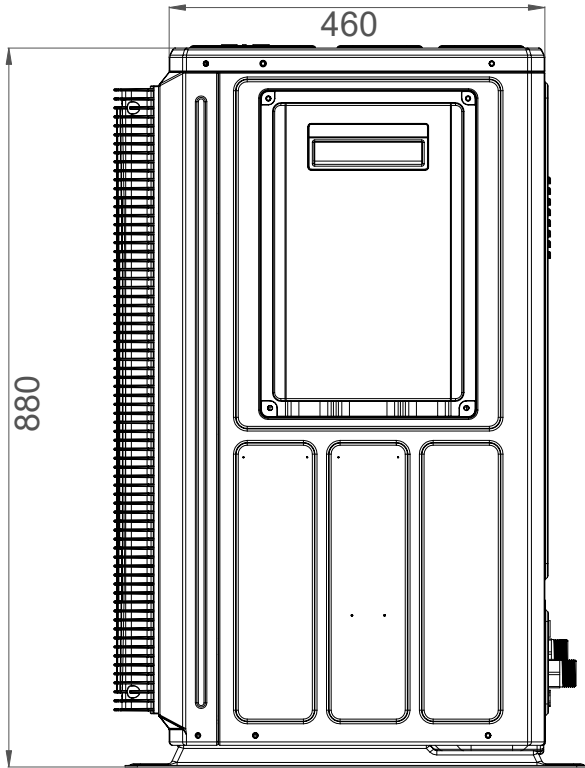

6. Center of Gravity

AW042MUGHA AW062MUGHA AW082MUGHA AW102MUGHA AW10NMUGHA

Unit: mm

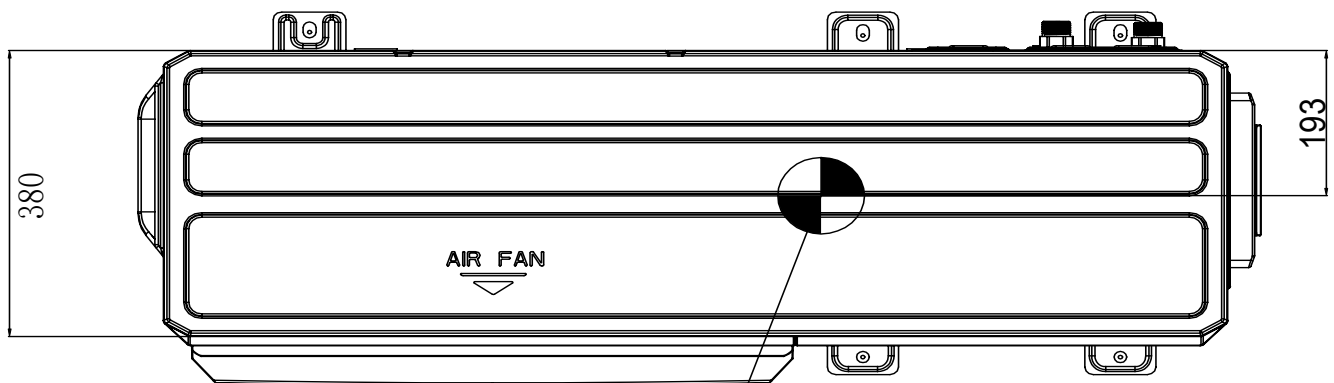
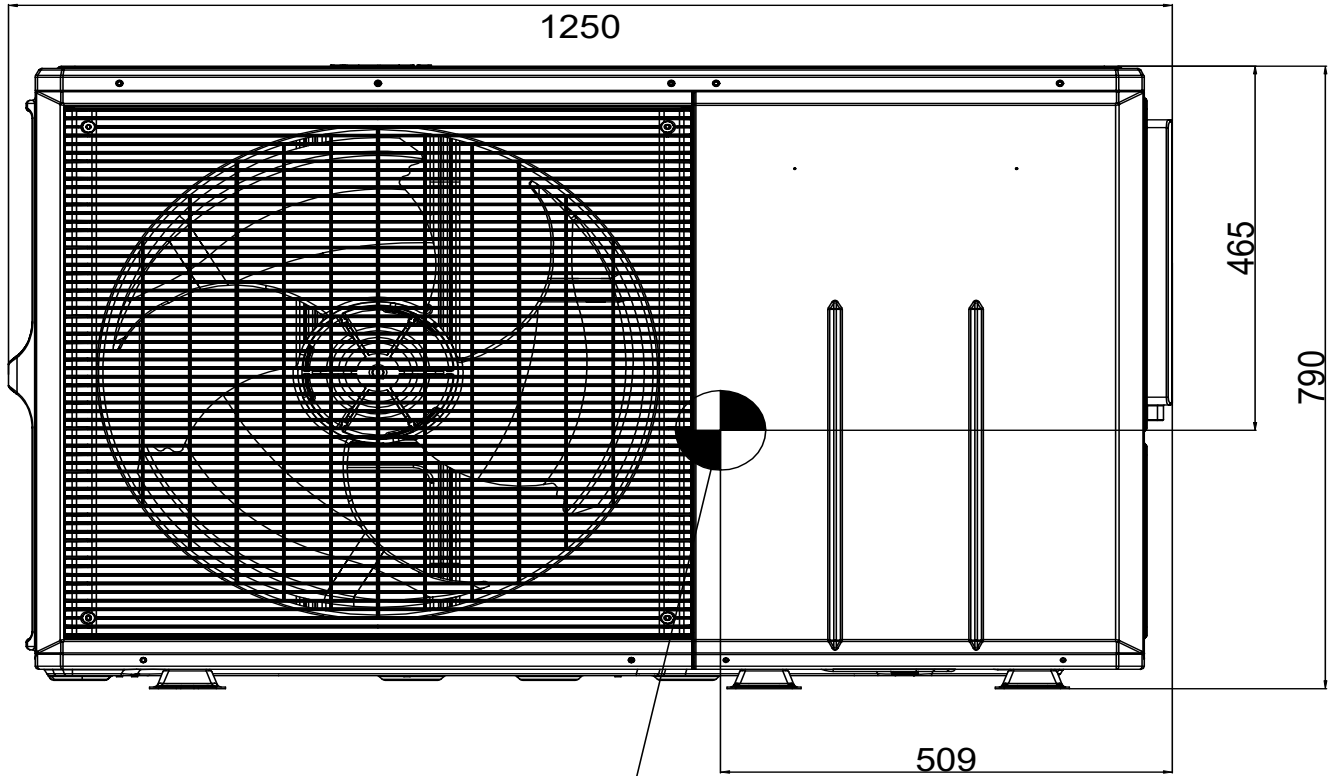

AW122MXGHA AW142MXGHA AW162MXGHA
AW12NMXGHA AW14NMXGHA AW16NMXGHA

Unit: mm

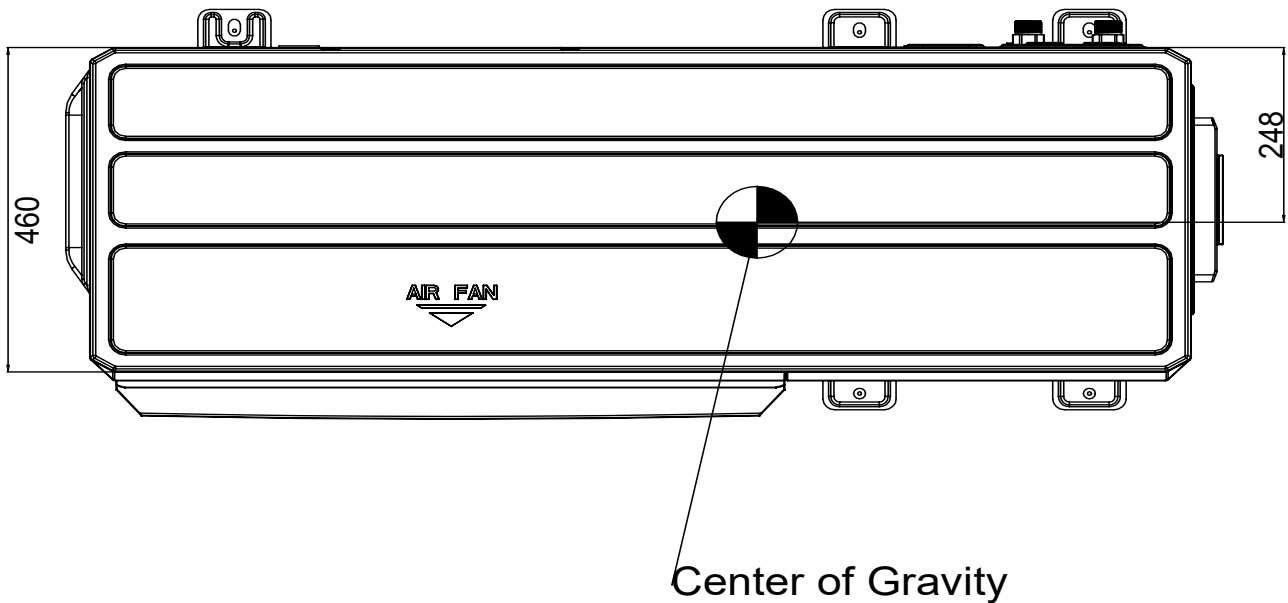
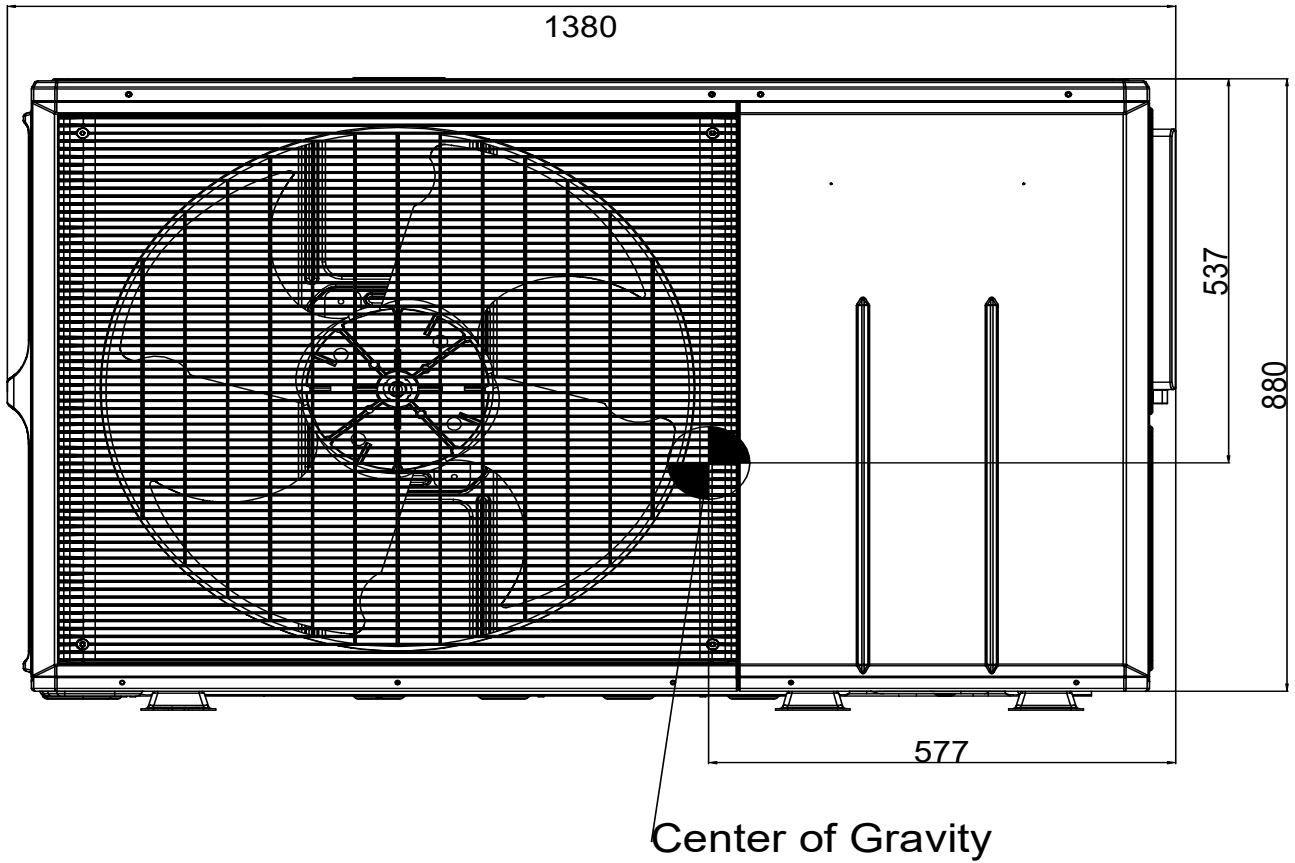

7. Piping Diagrams

Cooling

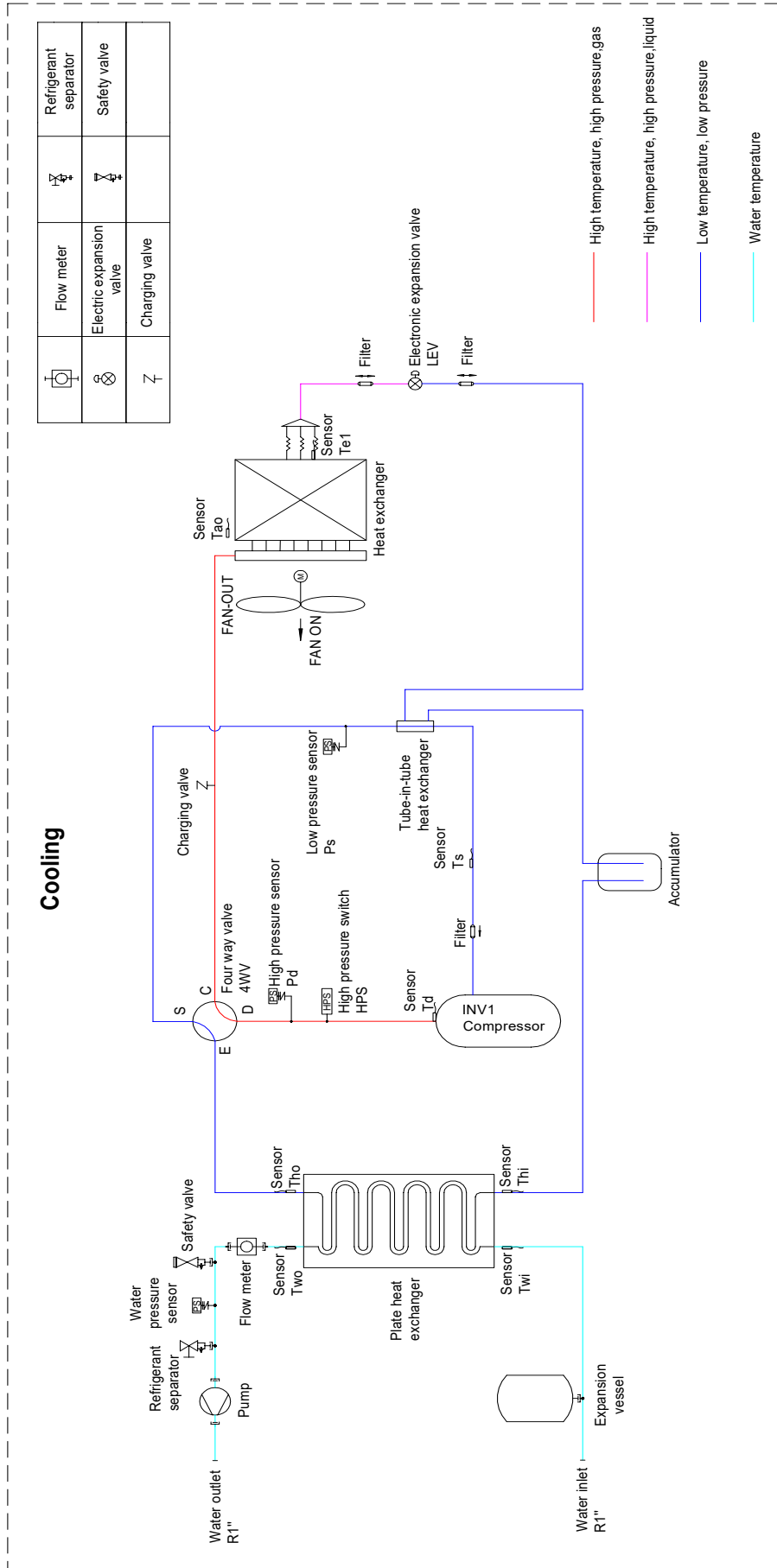

Heating

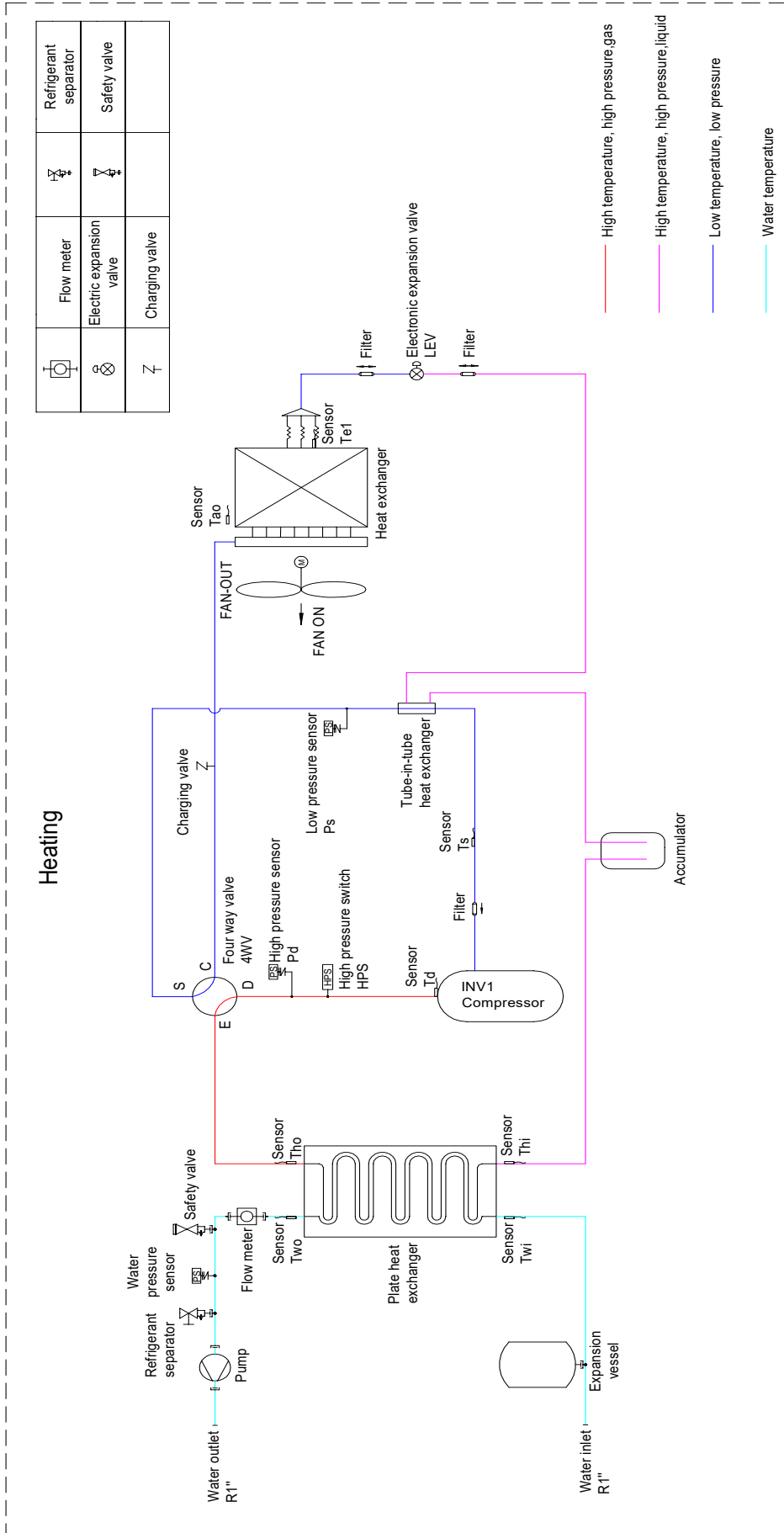

	Flow meter		Refrigerant separator
	Electric expansion valve		Safety valve
	Charging valve		

Part name	Model	abbr.	Function	Characteristics
Compressor	AW042MUGHA AW062MUGHA	Comp.	Capacity control, meet indoor load request by adjusting the frequency	Motor resistance(at 20°C):1.44±5%Ω
	AW082MUGHA AW102MUGHA AW10NMUGHA			Motor resistance(at 20°C):0.88±5%Ω
	AW122MXGHA AW142MXGHA AW12NMXGHA AW14NMXGHA			Motor resistance(at 20°C):0.54±5%Ω
	AW162MXGHA AW16NMXGHA			Motor resistance(at 20°C):0.54±5%Ω
Pressure Sensor	All	Pd	High pressure detection	Pressure range: 0 to 4.15 MPa
		Ps	Low pressure detection	Pressure range: 0 to 1.7 MPa
Pressure Switch	All	Hps	High pressure protection	break:3.3MPa reset:2.65MPa
Electronic Expansion Valve1	AW042MUGHA AW062MUGHA	LEVA	Refrigerant flow control	Ø1.8
	AW082MUGHA AW102MUGHA AW10NMUGHA AW122MXGHA AW142MXGHA AW12NMXGHA AW14NMXGHA			Ø2.4
	AW162MXGHA AW16NMXGHA			Ø3.0
Four Way Valve	AW042MUGHA AW062MUGHA	4WV	Change over between cooling and heating	AC220V, electrified in heat; not electrified in cooling or defrosting
	AW082MUGHA AW102MUGHA AW10NMUGHA			
	AW122MXGHA AW142MXGHA AW12NMXGHA AW14NMXGHA AW162MXGHA AW16NMXGHA			
Liquid Receiver	All	/	Used to storage the refrigerant	Volume:0.3L
Charging Valve	All	/	Used to charge the refrigerant to unit	Ø6.35
Flow Meter	All	/	Detect water flow	5~80 L/min

Part name	Model	abbr.	Function	Characteristics
Pump	AW042MUGHA AW062MUGHA AW082MUGHA AW102MUGHA AW10NMUGHA	Pump	Transport liquid	Pumping head:7.5m
	AW122MXGHA AW142MXGHA AW12NMXGHA AW14NMXGHA AW162MXGHA AW16NMXGHA			Pumping head:12.5m
Expansion Vessel	AW042MUGHA AW062MUGHA AW082MUGHA AW102MUGHA AW10NMUGHA	/	Pressure fluctuation of buffer system	4.5L
	AW122MXGHA AW142MXGHA AW12NMXGHA AW14NMXGHA AW162MXGHA AW16NMXGHA		Pressure fluctuation of buffer system	8L
Filter	All	/	Filter impurities	40 mesh
Refrigerant Separator	All	/	Release refrigerant from the water system	/
Plate Heat Exchanger	All	/	Used to exchange the heat from refrigerant to water	Design pressure of refrigerant side:4.5MPa
Pressure Relief Valve	All	/	Reduce system pressure	Operation pressure:0.3MPa
Air Purge Valve	All	/	Release gas from heating system and water supply pipeline	/
Temp. Sensor	All	Td	Discharge temp. of compressor	R80=50kΩ±3% B25/80=4450K
		Ts	Suction temp. of compressor	R25=10KΩ±3%; B25/50=3700K
		Te	Check frost condition of outdoor heat exchanger	R25=10KΩ±3%; B25/50=3700K
		Tao	Detect ambient temp. set primary setting for fan speed target pressure and PMV open angle	R25=10KΩ±3%; B25/50=3700K
		Thi	Detect the refrigerant inlet temp. of heat exchanger	R25=10KΩ±3%; B25/50=3700K
		Tho	Detect the refrigerant outlet temp. of heat exchanger	R25=10KΩ±3%; B25/50=3700K
		Twi	Detect the water inlet temp. of heat exchanger	R25=10KΩ±3%; B25/50=3700K
		Two	Detect the water outlet temp. of heat exchanger	R25=10KΩ±3%; B25/50=3700K

8. Wiring Diagrams

8.1 Wiring diagram of communication and power cables

Communication cable connection between IDU and ODU (IDU refers to ATW-A03N)

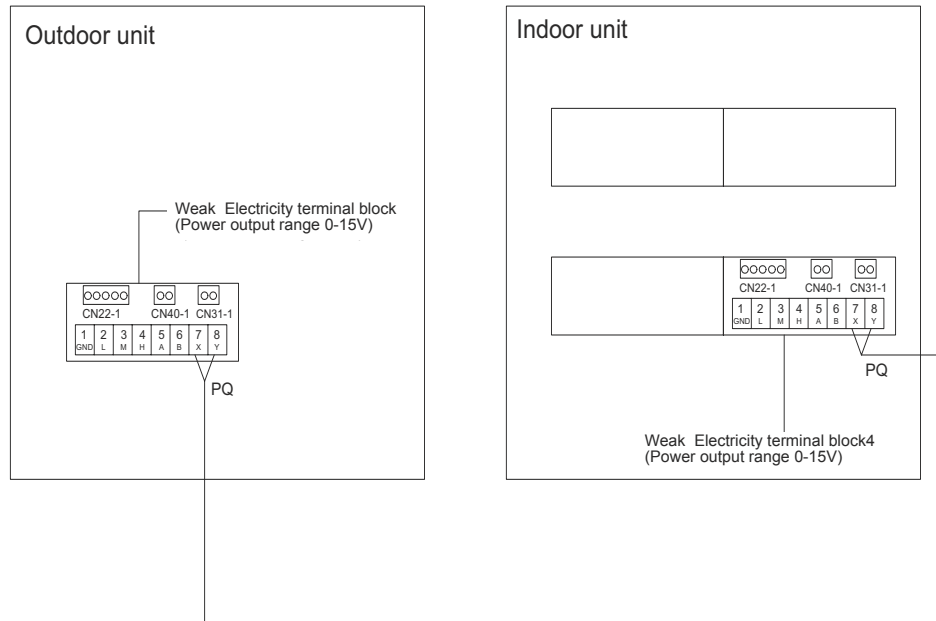

Communication wire to ATW-A03N

Length of Signal Line (m)	Wiring Dimensions
≤1000	0.75mm ² × 2 core shielding line

- The shielding lay of the signal line must be grounded at two side.

Connection of ODU power supply cable

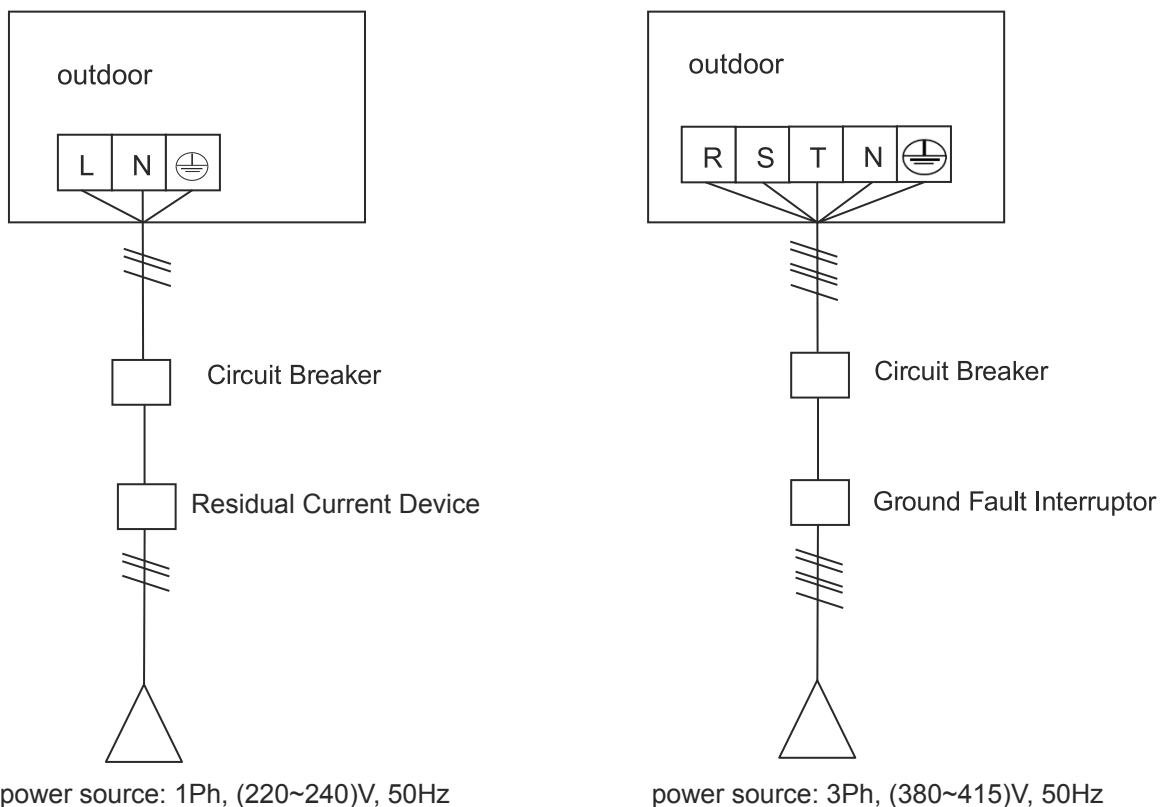

Connection of IDU power supply cable

Wiring instructions

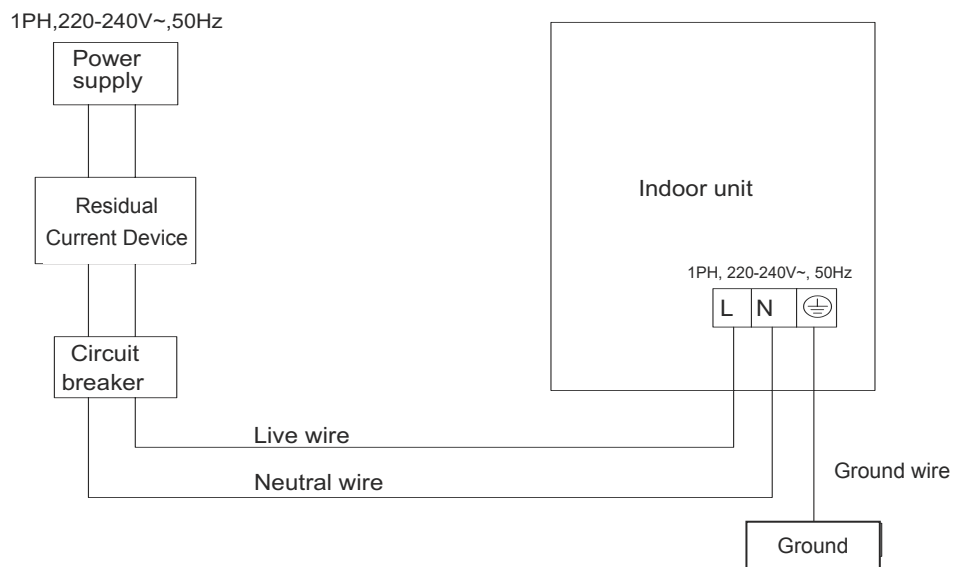

8.2 Wiring diagram of PCB

AW042MUGHA AW062MUGHA

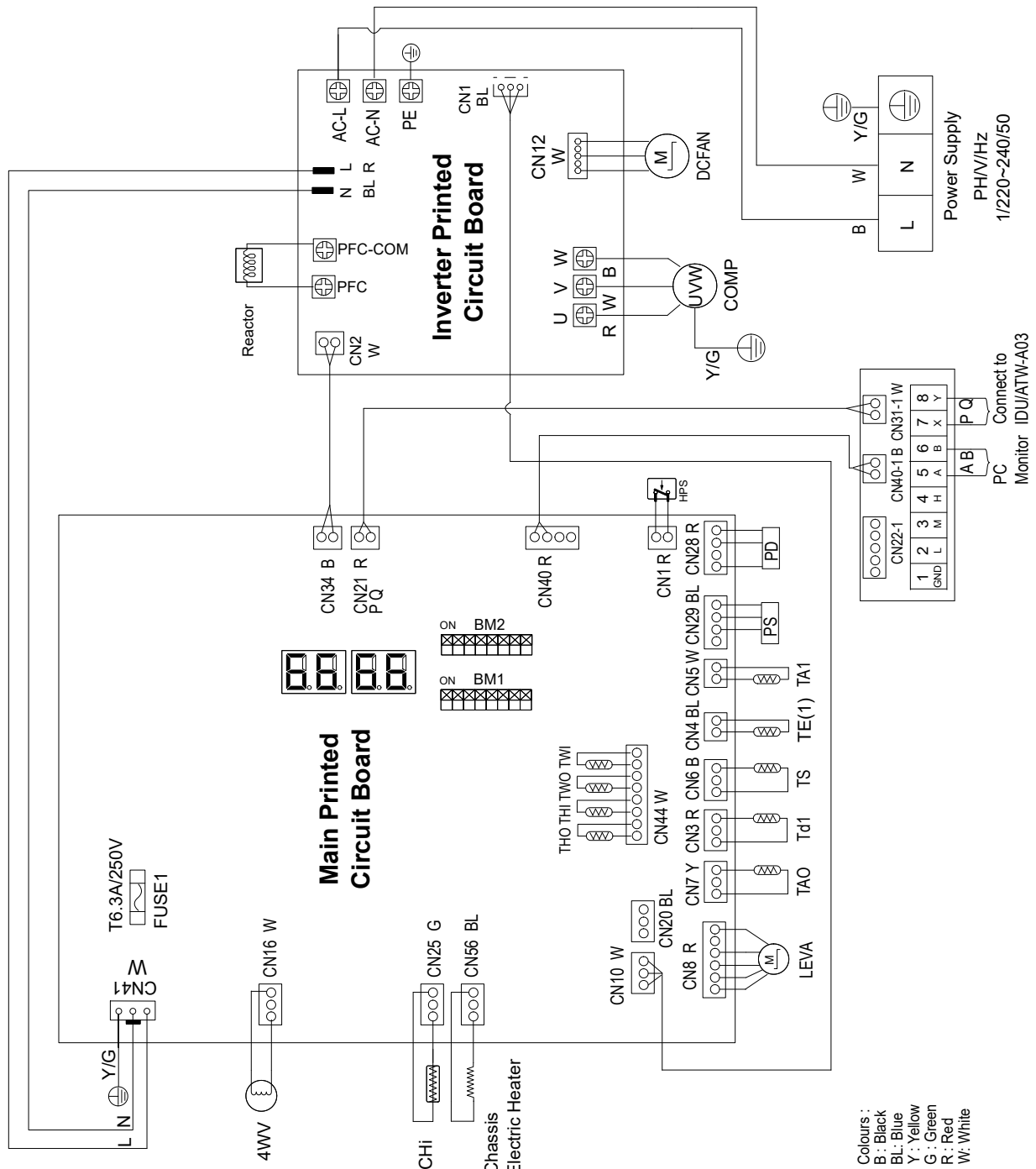

AW082MUGHA AW102MUGHA AW162MXGHA

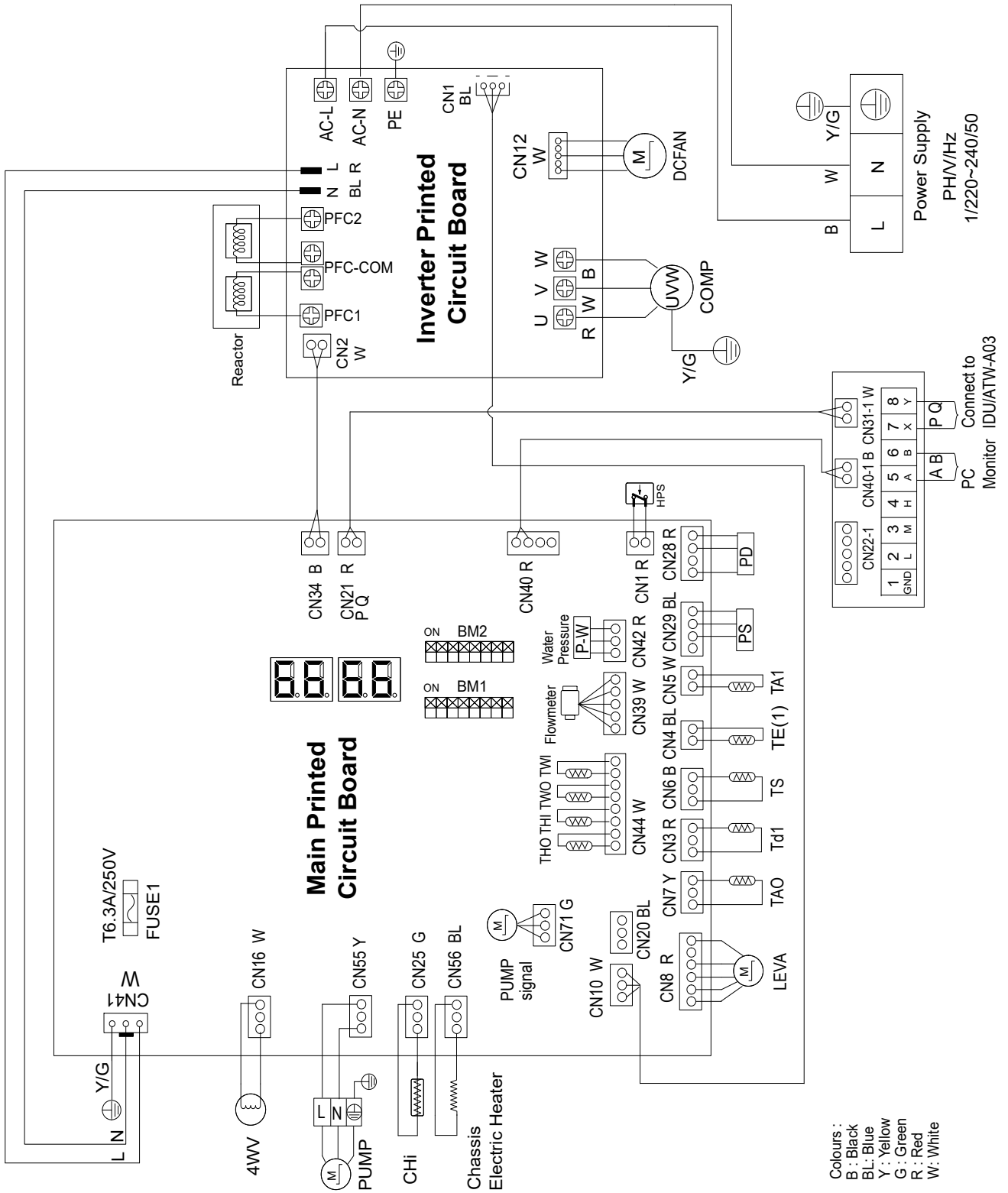

AW122MXGHA AW142MXGHA

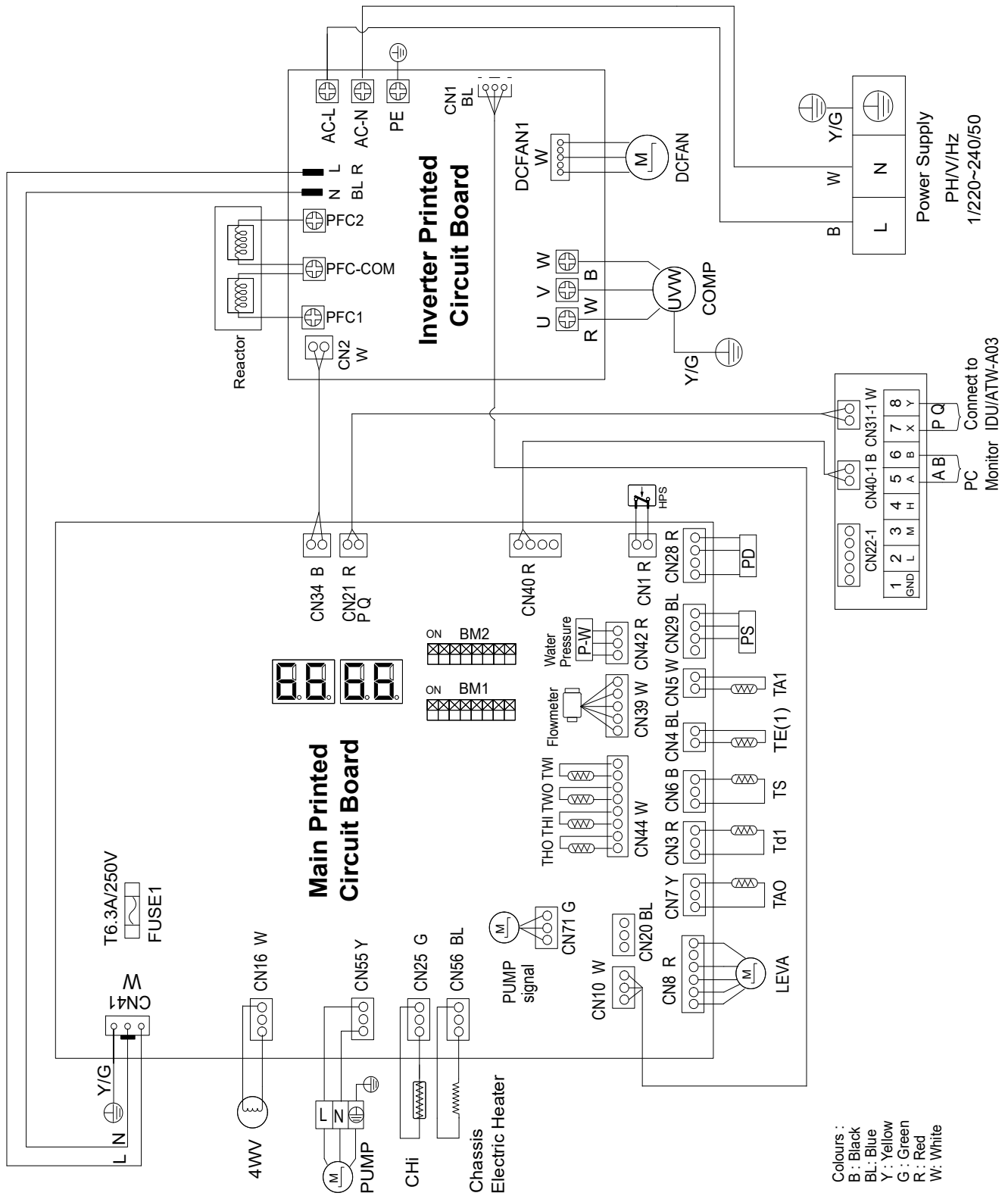

AW10NMUGHA AW12NMXGHA AW14NMXGHA AW16NMXGHA

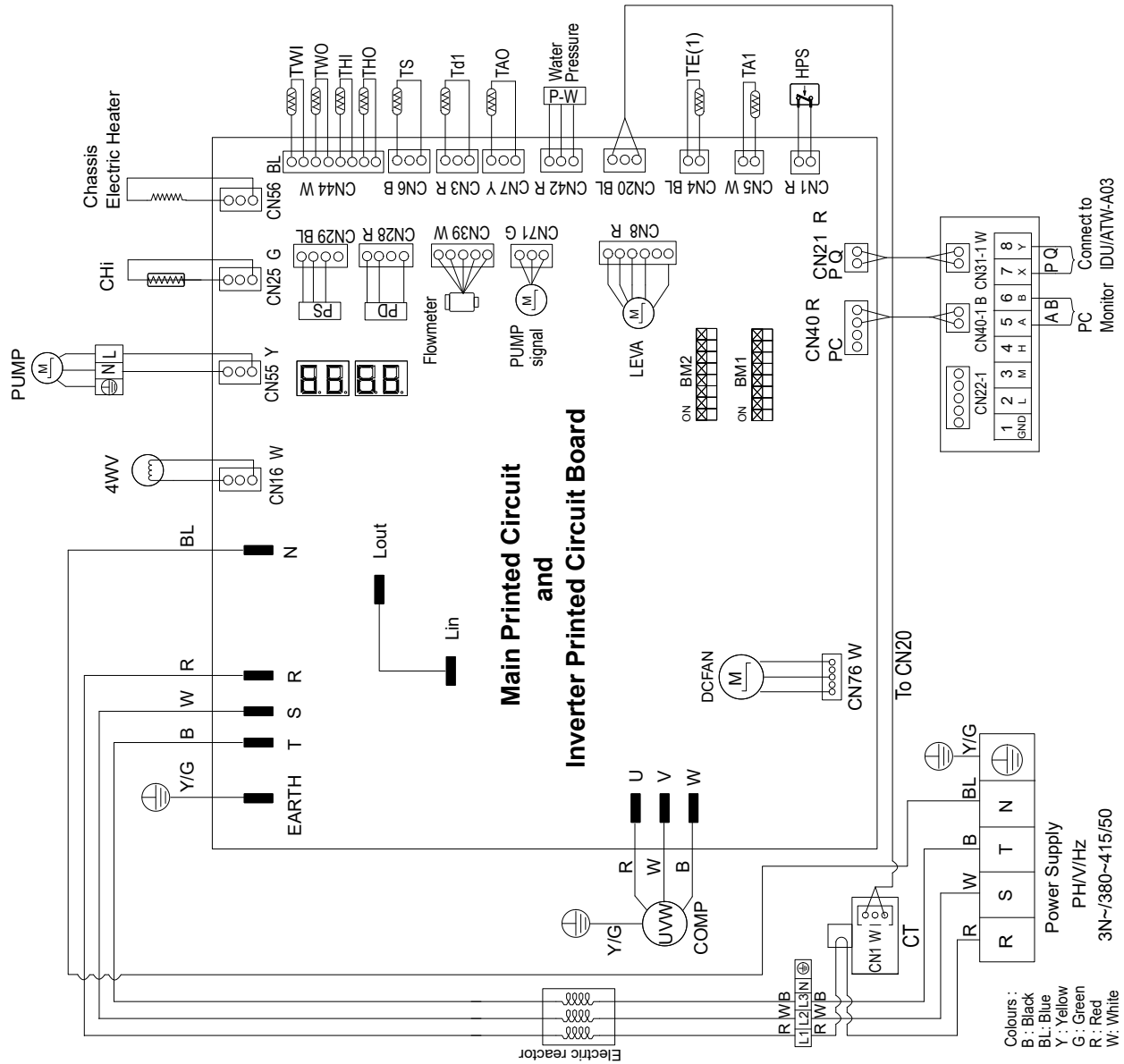

Port	Port Definition	Function Description
CN1	HPS	High Pressure Switch
CN3	Td1	Compressor Discharge Sensor
CN4	TE(1)	Defrost Detection Sensor
CN5	TA1	Internal Temperature Sensor of Electric Control Box
CN6	TS	Compressor Suction Sensor
CN7	TAO	Ambient Temperature Sensor
CN8	LEVA	Electronic Expansion Valve Control
CN10	INV-COM	INV Module Communication Port\C7(Single Phase Unit)
CN16	4WV	Four Way Valve
CN20	CT1	Input Current Detection(Three Phase Unit)
CN21	PQ	Internal and External Communication Wires
CN25	HEATER1	Compressor Crankcase Heater
CN28	PD	High Pressure Sensor
CN29	PS	Low Pressure Sensor
CN34	low-power consumption	Low-Power Consumption\C7(Single Phase Unit)
CN39	FM	Flowmeter
CN40	PC A/B	PC Communication Interface
CN41	Power Input	220V/50Hz Input
CN42	Wateroutlet	Water Pressure Sensor
CN44	TWO	Water Outlet Sensor of Plate Heat Exchanger
	TWI	Water Inlet Sensor of Plate Heat Exchanger
	THI	Liquid Tube of Plate Heat Exchanger
	THO	Gas Tube of Plate Heat Exchanger
CN55	Pump2	Built-in Water Pump Power
CN56	B-HEATER	Anti-Freezing Electric Heater of Chassis
CN71	DCPUMP	Built-in Water Pump Control Signal
CN76	DCFAN	Fan power output

ATW-A03N

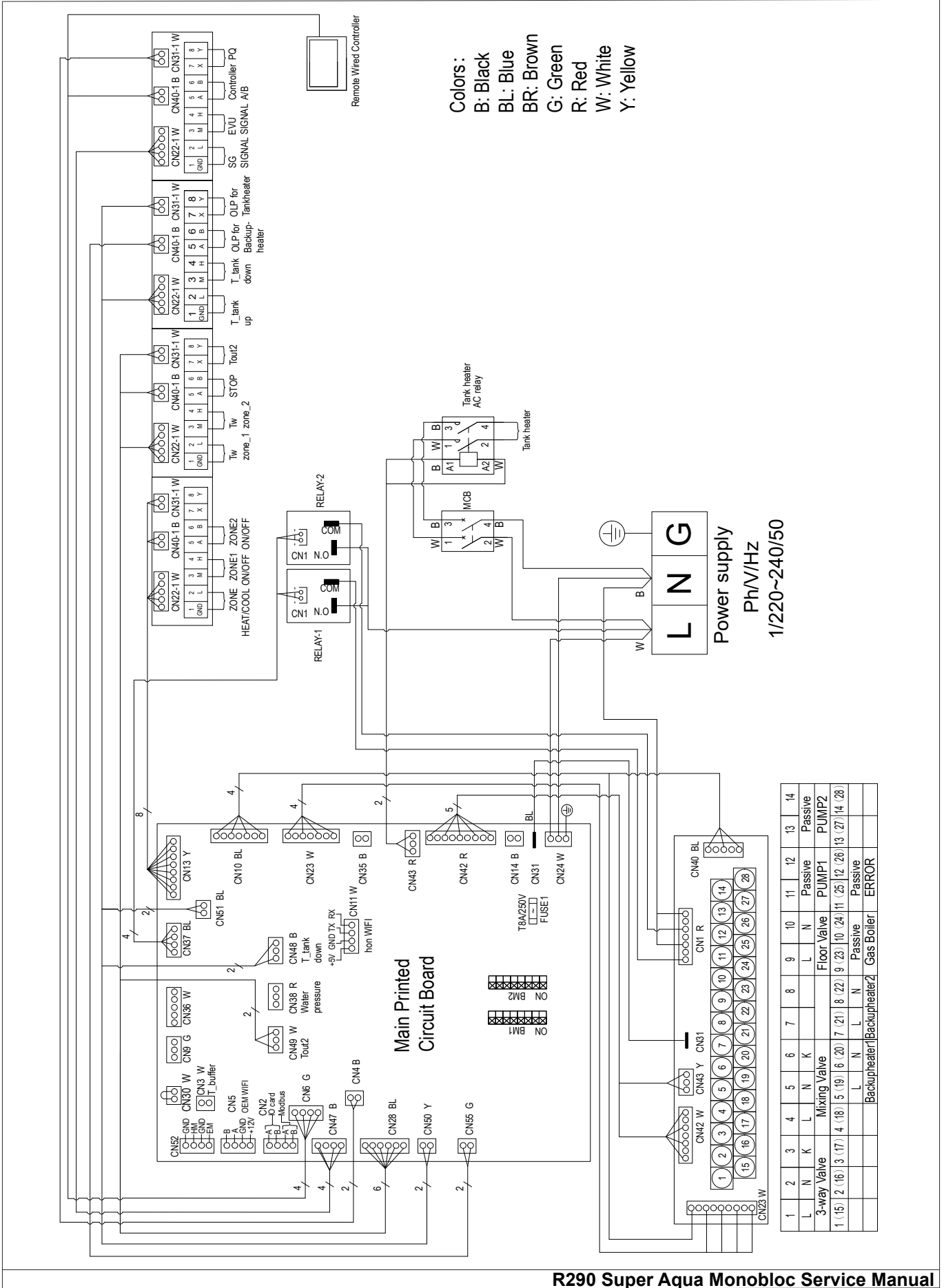

The wires that have already been connected in the factory

Port	Port Definition	Function Description
CN35	PUMP_0	HU Built-in Pump 220V AC Output
CN10	Gas Boiler	Gas Boiler Pump Control Signal Output(220V)
CN16	Antifreeze Heater	Antifreezing Electric Heating of Plate Heat Exchanger Control Signal Output(220V)
CN34	Tz	Outlet Temperature Sensor
CN38	P_w	Water Pressure Sensor
CN36	FM	Flowmeter

The wires that need to be connected on site

Port	Port Definition	Function Description
CN37	PUMP1	Zone1 Pump Control Signal Output(220V)
CN37	PUMP2	Zone2 Pump Control Signal Output(220V)
CN42	3 way valve	Zone1 Three Way Valve Control Output(220V)
CN42	Mixing valve	Zone2 Mixing Valve Control Output(220V)
CN42	Floor Valve	Floor Heating Valve Control Signal Output(220V)
CN43	Tank Heater	DHW Heater Control Signal Output(220V)
CN23	Backupheater1	Auxiliary Heating 1 Control Signal Output(220V)
CN23	Backupheater2	Auxiliary Heating 2 Control Signal Output(220V)
CN10	ERROR	Fault Output Signal(Passive)
CN28	Twzone_1	Zone1 Water Temperature Behind Water Mixing Valve
CN28	Twzone_2	Zone2 Water Temperature Behind Water Mixing Valve
CN3	T_buffer	Buffer Water Tank Temperature Sensor
CN50	T_tank up	Temperature Sensor on Upper Part of Tank
CN48	T_tank down	Temperature Sensor on Lower Part of Tank
CN49	Tout2	Afterheat Temperature Sensor
CN13	ZONE HEAT/COOL	Zone HEAT/COOL Switch Signal
CN13	ZONE1 ON/OFF	Zone1 ON/OFF Switch Signal
CN13	ZONE2 ON/OFF	Zone2 ON/OFF Switch Signal
CN28	STOP	Externally Controlled Stop
CN47	SG SIGNAL	SG READY 1 Signal
CN47	EVU SIGNAL	SG READY 2 Signal
CN6	controller A/B	Wired Controller A/B
CN4	PQ	Indoor Unit Communication With Outdoor Unit
CN2	Modbus	Third Party Agreement
CN2	IO card	The Indoor Unit Communicates With ATW-A03
CN52	EM	Energy Meter Interface
CN52	HM	Heat Meter Interface
CN5	OEM WIFI	TUYA WIFI Interface
CN11	hon WIFI	CANDY WIFI Interface
CN55	OLP for Backupheater	Auxiliary Electric Heater Protection Signal Feedback Port
CN51	OLP for Tankheater	DHW Auxiliary Electric Heater Protection Signal Feedback Port

Wiring instructions of third party control wiring instructions

Type1:

ZONE1

Heating Mode

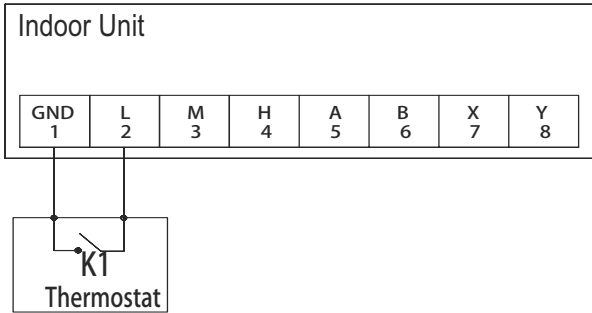

Cooling Mode

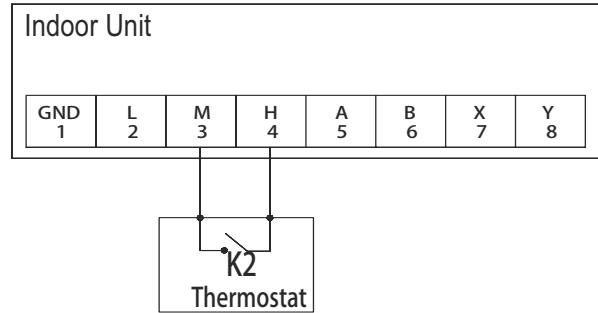

K1: Switch-On represents Heating Mode On; Switch-Off represents Heating Mode Off.

K2: Switch-On represents Cooling Mode On; Switch-Off represents Cooling Mode Off.

K1 and K2 are not allowed to be switched on simultaneously

ZONE2

Heating Mode

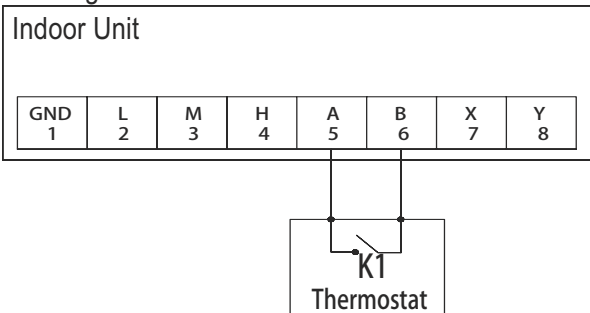

Cooling Mode

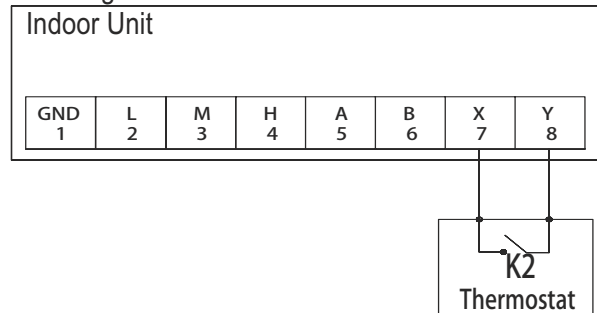

K1: Switch-On represents Cooling Mode On; Switch-Off represents Cooling Mode Off.

K2: Switch-On represents the Heating Mode On; Switch-Off represents Heating Mode Off.

K1 and K2 are not allowed to be switched on simultaneously

Type2:

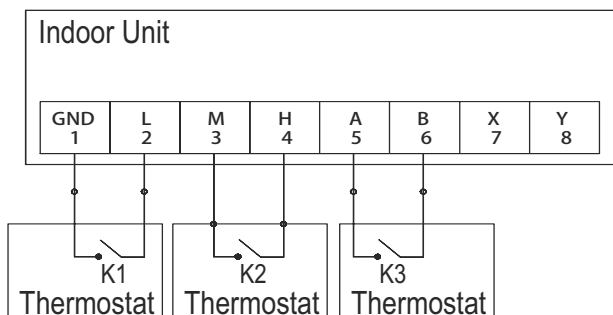

Cooling/Heating Mode ZONE1 ON/OFF ZONE2 ON/OFF

K1: Switch-On represents Cooling Mode ZONE1/ZONE2 On; Switch-Off represents Heating Mode ZONE1/ZONE2 On

K2: Switch-On represents ZONE1 On; Switch-Off represents ZONE1 Off.

K3: Switch-On represents ZONE2 On; Switch-Off represents ZONE2 Off.

Zone Heat/Cool

This interface is the switching of heating and cooling between zone1 and zone2;
Use a two-core cable to enter the electronic control box from the rubber plug hole, connect the lead to the terminal block, press and install with screws.
The other end of the cable is connected to the zone1 and zone2 heating and cooling ports outside the electric cabinet. This control port should be passive and only output on-off signals.

Zone1 On/Off

Use a two-core cable to enter the electronic control box from the rubber plug hole, connect the lead to the terminal block, press and install with screws.

Zone2 On/Off

Use a two-core cable to enter the electronic control box from the rubber plug hole, connect the lead to the terminal block, press and install with screws.

Tw Zone_1

Install the 0150408957 sensor, entering the electronic control box through the rubber plug hole, where the lead is connected to the terminal block, press and install with screws.
The temperature sensing probe of the sensor must be installed in a proper position behind the Zone1 water mixing valve, according to the actual situation on site.

Tw Zone_2

Install the 0150408957 sensor, entering the electronic control box through the rubber plug hole, where the lead is connected to the terminal block, press and install with screws.
The temperature sensing probe of the sensor must be installed in a proper position behind the Zone1 water mixing valve, according to the actual situation on site.

STOP

Use a two-core cable to enter the electronic control box from the rubber plug hole, connect the lead to the terminal block, press and install with screws.
The other end of the cable is connected to the on-off switch control port outside the electrical control box. This control port should be passive, only outputting on-off signals.

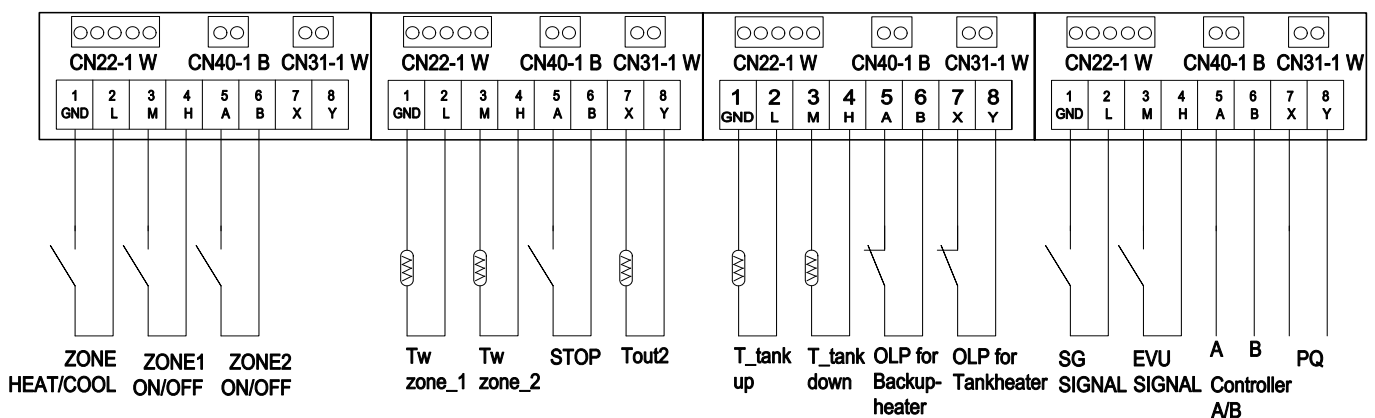

Weak Electricity terminal block interface of internal

Tout2

This interface is the electric auxiliary hot water outlet temperature sensor.

The sensor cable enters the electronic control box from the rubber plug hole, connect the lead to the terminal block, press and install with screws.

According to the actual situation on site, the temperature sensing probe of the sensor is installed at the appropriate position of the electrical auxiliary hot water outlet. It must then be completely wrapped with thermal insulation cotton and firmly fixed with a cable tie.

T_tank up

The sensor cable enters the electronic control box from the rubber plug hole, connect the lead to the terminal block, press and install with screws.

According to the actual situation on site, the temperature sensing probe of the sensor is installed at the temperature detection position of the upper part of the water tank and must be fixed.

T_tank down

The sensor cable enters the electronic control box from the rubber plug hole, connect the lead to the terminal block, press and install with screws.

According to the actual situation on site, the temperature sensing probe of the sensor is installed at the temperature detection position of the upper part of the water tank and must be fixed.

OLP for backup heater (use the same font size for the following text)

Use a two-core cable to enter the electronic control box from the rubber plug hole, connect the lead to the terminal block, press and install with screws.

The other side of the cable is connected to the feedback signal control port of the electric auxiliary thermal protection outside the electrical control box. This control port should be passive, only outputting on-off signals.

OLP for Tankheater

Use a two-core cable to enter the electronic control box from the rubber plug hole, connect the lead to the terminal block, press and install with screws.

The other side of the cable is connected to the feedback signal control port of the electric auxiliary thermal protection outside the electrical control box. This control port should be passive, only outputting on-off signals.

The machine is in normal operation when the two terminals of OLP for backup heater are connected. The machine will stop running when the two terminals are disconnected for electrical auxiliary thermal protection. When this protection is not used, the two terminals should be short-circuited with wires.

SG Signal

Use a two-core cable to enter the electronic control box from the rubber plug hole, connect the lead to the terminal block, press and install with screws.

The other end of the cable is connected to the power grid signal control port outside the electrical cabinet. This control port should be passive, only outputting on-off signals.

EVU Signal

Use a two-core cable to enter the electronic control box from the rubber plug hole, connect the lead to the terminal block, press and install with screws.

The other end of the cable is connected to the power grid signal control port outside the electrical cabinet. This control port should be passive, only outputting on-off signals.

Controller A/B

This interface is a data communication port to the wire controller, this can be used to connect the indoor temperature and humidity meter to the controller.

Use a two-core shielded cable to enter the electronic control box from the rubber plug hole, connect the lead to the terminal block, press and install with screws.

the other end of the cable is connected to the thermometer or wire controller outside of the electrical cabinet. Pay attention to the one-to-one correspondence between terminal A and B, both inside and outside of the electric cabinet.

PQ

Use a two-core shielded cable to enter the electronic control box from the rubber plug hole, connect the lead to the terminal block, press and install with screws. The shielding layer is must be connected to the metal plate for grounding.

The other end of the cable is connected to the PQ terminal in the outdoor machine. Press and install it with screws, the shielding layer is grounded with the metal sheet of the outdoor machine.

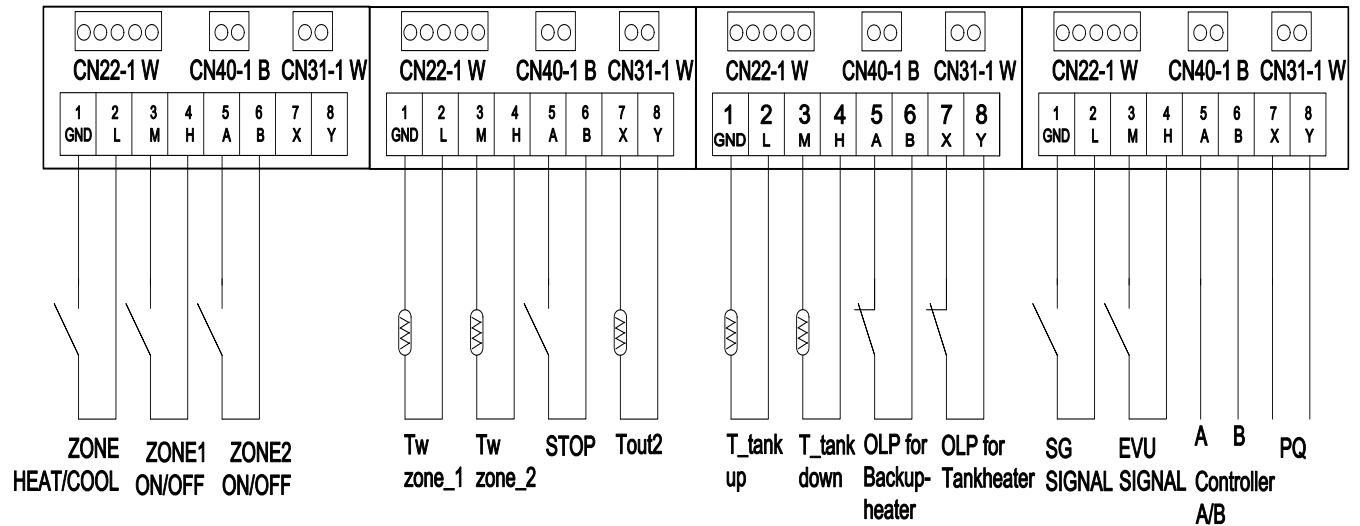

Weak Electricity terminal block interface of internal

3-way Valve

This interface is the 3-way valve control.

When it is necessary to install the 3-way valve, the wiring and terminal connections enter the electrical control box via the rubber plug hole. Wires L, N and K respectfully represent live, neutral and grounding lines. Connect the lead to the terminal block, press and install with screws.

Mixing Valve

This interface is the water mixing valve control

When it is necessary to install the mixing valve, the wiring and terminal connections enter the electrical control box via the rubber plug hole. Wires L, N and K respectfully represent live, neutral and grounding lines. Connect the lead to the terminal block, press and install with screws.

Floor Valve

This interface is the control for the floor heating main valve.

When it is necessary to install the floor heating main valve, the wiring and terminal connections enter the electrical control box via the rubber plug hole. Wires L, N and K respectfully represent live, neutral and grounding lines. Connect the lead to the terminal block, press and install with screws.

PUMP1

This interface is the outdoor AC water pump power supply used by Zone1.

The terminal enters the electrical control box through the rubber plug hole. Wires L and N respectfully represent live and neutral lines.

Connect L and N power supply lines to the terminal block, press and install with screws. The grounding wire of the water pump enters the control box with the power supply line path, which is reliably grounded at the grounding mark.

The voltage between L and N is the rated voltage input by the power terminal block. Power of the selected water pump must not be greater than 180W.

PUMP2

This interface is the outdoor AC water pump power supply used by Zone2.
The terminal enters the electrical control box through the rubber plug hole. Wires L and N respectfully represent live and neutral lines.
Connect L and N power supply lines to the terminal block, press and install with screws. The grounding wire of the water pump enters the control box with the power supply line path, which is reliably grounded at the grounding mark.
The voltage between L and N is the rated voltage input by the power terminal block. Power of the selected water pump must not be greater than 180W.

Backup Heater1

This interface is the electric auxiliary heating 1 switch control.
The terminal enters the electrical control box through the rubber plug hole. Wires L and N respectfully represent live and neutral lines.
The voltage between L and N is the rated voltage input by the computer version. This is a control loop which can only be connected to the secondary control loop, this cannot be directly connected to the auxiliary thermal power supply.

Backup Heater2

This interface is the electric auxiliary heating 2 switch control.

Gas Boiler :

This interface is the gas furnace control opening interface. This interface is a passive contact output port, which only outputs on-off control signals;
Use a two-core cable to penetrate into the electronic control box from the rubber plug hole, and connect the lead to the terminal block and press and install it with screws;
The other end of the cable is connected to the control interface of the gas furnace.

ERROR :

This interface is the fault output signal interface. This interface is a passive contact output port, which only outputs on-off control signals;
Use a two-core cable to penetrate into the electronic control box from the rubber plug hole, and connect the lead to the terminal block and press and install it with screws;
The other end of the cable is connected to the fault input interface outside the electric cabinet.

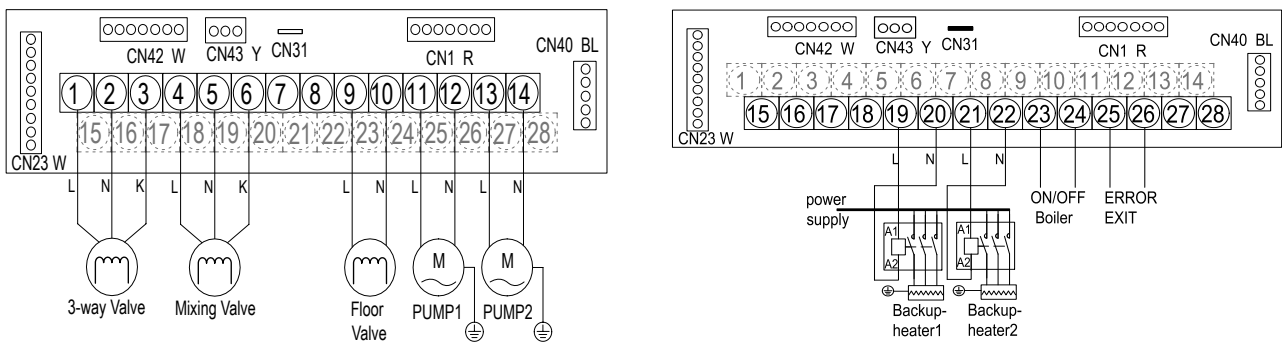

Strong Electricity terminal block interface of internal

Tank Heater

This is interface 2 and 4 on the contactor, which is the main power supply for electric heating in the water tank. Terminals L, N and the grounding wire for electric heating in the water tank enter the electric control box through the rubber plug hole. Power lines L and N are respectively connected to 2 and 4 interfaces of the AC contactor. The grounding wire is reliably grounded at the grounding symbol of the electrical control box. The maximum operating current of the electrical heater used in the water tank must be less than 20A.

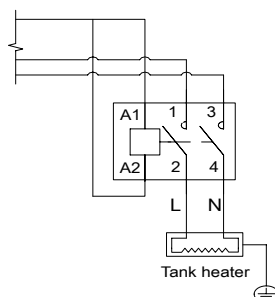

AC contactor interface of internal

CN3

This interface is the buffer water tank temperature sensor. The plug end enters the electrical control box through the rubber plug hole and is inserted into the port CN3 on the PCB. One end of the temperature sensing probe is installed at the corresponding position of the buffer tank in order to detect the temperature.

CN52

The HM interface is heat meter and the EM interface is the electric meter. The heat meter is connected to the HM and GND ports of the PCB CN52, by a two-core cable. The cable enters the electronic control box via the rubber plug hole where the interface must press the lead on the PCB. The electric meter is connected to the HM and GND ports of the PCB CN52, by a two-core cable. The cable enters the electronic control box via the rubber plug hole where the interface must press the lead on the PCB.

CN5

This is the interface for the OEM WIFI. The WIFI module is connected to the CN5 port of the PCB by a four-core cable. The interfaces B, A and GND and a +12V on the PCB should correspond to the interface functions on the WIFI module. The interface on the PCB needs to press the lead.

CN2

The IO card interface is the external wiring valve box interface, which can be connected to ATW-A02. Modbus, which is a third party control interface. Use a two-core cable to enter the electronic control box through the rubber plug hole, connect to A and B ports of the IO card of the PCB, CN2. The other end of the cable is connected with A and B phases of the external wiring valve box. Note that A and B need to correspond to each other. Use a two core cable to enter the electronic control box through the rubber plug hole. Connect it with A and B ports of Modbus at CN2 of the PCB. The other end of the cable is connected with ports A and B phases of a third-party controller. Note that A and B need to correspond to each other. The interface on the PCB needs to press the lead.

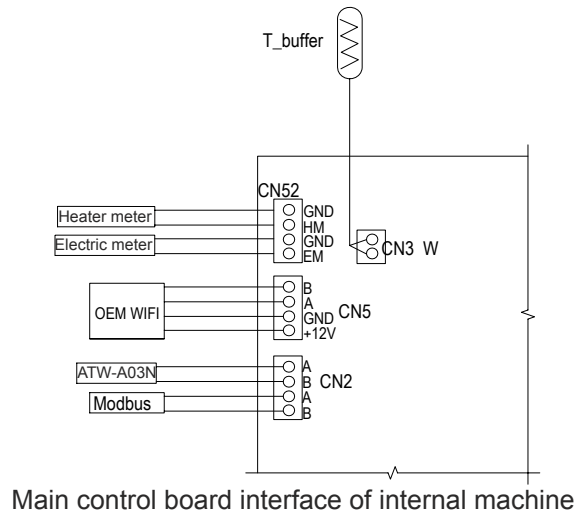

A, B

Use two-core wires to connect and press to the weak current wiring terminal block with screws. Connect the other end to the computer monitor.

P, Q

Use two-core wires with a shielding layer, connect and press to the weak current terminal block with screws. Connect the other end to the PQ wiring terminal of the internal machine or ATW-A03N. The cable shielding layer is grounded with the external machine's sheet metal.

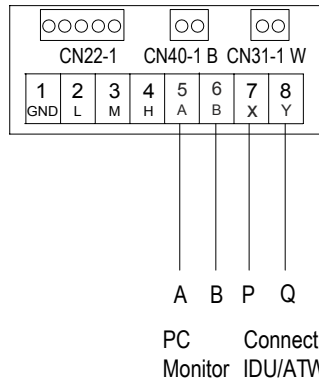

Weak current terminal block interface of external machine

9. Electric Characteristics

Monobloc	Power Supply					MCA (A)	MFA (A)	MSC(A)	OFM	
	Hz	Voltage	Phase	Min	Max				Kw	FLA (A)
AW042MUGHA	50Hz	220-240V	1Ph	198V	264V	13.5	16	2	0.16	1.1
AW062MUGHA	50Hz	220-240V	1Ph	198V	264V	13.5	16	2	0.16	1.1
AW082MUGHA	50Hz	220-240V	1Ph	198V	264V	18.6	20	2	0.16	1.1
AW102MUGHA	50Hz	220-240V	1Ph	198V	264V	18.6	20	2	0.16	1.1
AW122MXGHA	50Hz	220-240V	1Ph	198V	264V	30.6	32	2	0.375	2.3
AW142MXGHA	50Hz	220-240V	1Ph	198V	264V	30.6	32	2	0.375	2.3
AW162MXGHA	50Hz	220-240V	1Ph	198V	264V	34.8	40	2	0.375	2.3
AW10NMUGHA	50Hz	380-415V	3Ph	342V	456.5V	6.2	16	2	0.375	0.8
AW12NMUGHA	50Hz	380-415V	3Ph	342V	456.5V	10.2	16	2	0.375	0.8
AW14NMUGHA	50Hz	380-415V	3Ph	342V	456.5V	10.2	16	2	0.375	0.8
AW16NMUGHA	50Hz	380-415V	3Ph	342V	456.5V	11.6	16	2	0.375	0.8

Remark:

- MCA: Min. Circuit Amps. (A)
- MFA: Max. Fuse Amps. (A)
- MSC: Max. Starting Amps. (A)
- OFM: Outdoor Fan Motor
- FLA: Full Load Amps. (A)
- kW: Rated Motor Output (kW)

10. Capacity Tables

10.1 Cooling capacity

AW042											
Water Out(°C)	5		7		14		18		25		
Ambient Temperature(°C)	Capacity	EER	Capacity	EER	Capacity	EER	Capacity	EER	Capacity	EER	
Max.	10	2701	2.83	3859	4.64	4350	6.04	4631	7.06	4769	7.74
	15	2585	2.66	3822	4.37	4282	5.58	4544	6.43	4464	7.20
	25	2353	2.34	3749	3.92	4145	4.80	4372	5.41	3854	6.12
	35	2121	2.03	3675	3.53	4009	4.18	4200	4.61	3244	5.08
	48	1819	1.67	2021	2.43	2249	3.03	2379	3.44	2451	3.77
Nom.	10	2573	3.24	3675	4.86	4143	6.49	4410	7.73	4542	8.85
	15	2462	3.04	3640	4.58	4078	6.00	4328	7.04	4252	8.22
	25	2241	2.67	3570	4.10	3948	5.17	4164	5.92	3671	7.00
	35	2020	2.32	3500	3.70	3818	4.50	4000	5.05	3089	5.81
	48	1733	1.91	1925	2.54	2142	3.25	2266	3.76	2334	4.31
Mid.	10	1405	3.43	1929	5.45	2175	7.16	2315	8.41	2385	9.33
	15	1344	3.22	1911	5.14	2141	6.61	2272	7.65	2232	8.67
	25	1224	2.82	1874	4.61	2073	5.69	2186	6.43	1927	7.38
	35	1103	2.46	1838	4.16	2005	4.96	2100	5.49	1622	6.12
	48	946	2.02	1011	2.86	1125	3.59	1190	4.09	1225	4.54
Min.	10	675	3.54	965	6.10	1087	7.95	1158	9.29	1216	10.67
	15	646	3.33	956	5.75	1070	7.34	1136	8.46	1138	9.92
	25	588	2.92	937	5.15	1036	6.32	1093	7.11	983	8.44
	35	530	2.54	919	4.65	1002	5.51	1050	6.07	827	7.00
	48	455	2.09	505	3.19	562	3.98	595	4.52	625	5.20

AW062											
Water Out(°C)	5		7		14		18		25		
Ambient Temperature(°C)	Capacity	EER	Capacity	EER	Capacity	EER	Capacity	EER	Capacity	EER	
Max.	10	3859	2.79	5513	4.57	6425	6.00	6946	6.99	7154	7.67
	15	3693	2.63	5460	4.31	6323	5.54	6817	6.37	6696	7.12
	25	3361	2.30	5355	3.86	6121	4.77	6558	5.35	5781	6.06
	35	3030	2.01	5250	3.48	5918	4.15	6300	4.57	4866	5.03
	48	2599	1.65	2888	2.40	3321	3.00	3569	3.40	3676	3.73
Nom.	10	3675	3.19	5250	4.79	6119	6.45	6615	7.66	6813	8.76
	15	3517	3.00	5200	4.52	6022	5.96	6492	6.97	6378	8.14
	25	3201	2.63	5100	4.05	5829	5.13	6246	5.86	5506	6.93
	35	2886	2.29	5000	3.65	5636	4.47	6000	5.00	4634	5.75
	48	2475	1.88	2750	2.51	3163	3.23	3399	3.73	3501	4.27
Mid.	10	2007	3.38	2756	5.38	3212	7.11	3473	8.32	3577	9.24
	15	1920	3.17	2730	5.07	3162	6.56	3408	7.58	3348	8.58
	25	1748	2.79	2678	4.54	3060	5.65	3279	6.37	2891	7.30
	35	1575	2.43	2625	4.10	2959	4.92	3150	5.43	2433	6.06
	48	1351	1.99	1444	2.82	1661	3.56	1784	4.05	1838	4.50
Min.	10	965	3.49	1378	6.02	1606	7.90	1736	9.20	1824	10.57
	15	923	3.28	1365	5.68	1581	7.29	1704	8.38	1708	9.82
	25	840	2.88	1339	5.08	1530	6.27	1640	7.04	1474	8.36
	35	757	2.51	1313	4.58	1480	5.46	1575	6.01	1241	6.93
	48	650	2.06	722	3.15	830	3.95	892	4.48	937	5.14

AW082											
Water Out(°C)		5		7		14		18		25	
Ambient Temperature(°C)		Capacity	EER	Capacity	EER	Capacity	EER	Capacity	EER	Capacity	EER
Max.	10	5248	2.64	7497	4.32	8251	5.64	8682	6.64	8943	7.28
	15	5022	2.48	7426	4.08	8123	5.21	8521	6.05	8371	6.77
	25	4571	2.18	7283	3.65	7865	4.49	8198	5.08	7226	5.76
	35	4121	1.90	7140	3.29	7608	3.91	7875	4.34	6082	4.78
	48	3534	1.56	3927	2.26	4267	2.83	4461	3.23	4595	3.55
Nom.	10	4998	3.02	7140	4.53	7858	6.06	8269	7.27	8517	8.32
	15	4783	2.84	7072	4.27	7736	5.60	8115	6.62	7972	7.74
	25	4354	2.49	6936	3.83	7491	4.83	7808	5.57	6882	6.58
	35	3924	2.17	6800	3.45	7245	4.21	7500	4.75	5793	5.46
	48	3366	1.78	3740	2.37	4064	3.04	4249	3.54	4376	4.05
Mid.	10	2729	3.19	3749	5.09	4126	6.68	4341	7.91	4471	8.78
	15	2612	3.00	3713	4.80	4061	6.17	4260	7.20	4185	8.15
	25	2377	2.63	3641	4.30	3933	5.32	4099	6.05	3613	6.94
	35	2143	2.29	3570	3.87	3804	4.64	3938	5.16	3041	5.76
	48	1838	1.88	1964	2.66	2133	3.35	2231	3.85	2298	4.27
Min.	10	1312	3.30	1874	5.69	2063	7.42	2171	8.74	2280	10.04
	15	1256	3.10	1856	5.36	2031	6.86	2130	7.96	2135	9.33
	25	1143	2.72	1821	4.80	1966	5.91	2049	6.69	1843	7.94
	35	1030	2.37	1785	4.33	1902	5.15	1969	5.71	1551	6.59
	48	884	1.95	982	2.98	1067	3.72	1115	4.25	1172	4.89

AW102/10N											
Water Out(°C)		5		7		14		18		25	
Ambient Temperature(°C)		Capacity	EER	Capacity	EER	Capacity	EER	Capacity	EER	Capacity	EER
Max.	10	6560	2.49	9371	4.07	10406	5.20	10997	6.01	11327	6.59
	15	6278	2.34	9282	3.84	10244	4.80	10793	5.47	10603	6.13
	25	5714	2.05	9104	3.44	9918	4.14	10384	4.60	9154	5.21
	35	5151	1.79	8925	3.10	9593	3.60	9975	3.93	7704	4.33
	48	4418	1.47	4909	2.13	5381	2.60	5651	2.93	5820	3.21
Nom.	10	6248	2.84	8925	4.27	9911	5.59	10474	6.58	10788	7.54
	15	5979	2.67	8840	4.02	9756	5.16	10279	6.00	10098	7.00
	25	5442	2.34	8670	3.60	9446	4.45	9890	5.04	8718	5.96
	35	4905	2.04	8500	3.25	9136	3.88	9500	4.30	7337	4.94
	48	4208	1.68	4675	2.23	5125	2.80	5382	3.21	5543	3.67
Mid.	10	3411	3.01	4686	4.79	5203	6.16	5499	7.16	5664	7.94
	15	3265	2.83	4641	4.52	5122	5.69	5396	6.52	5301	7.38
	25	2971	2.48	4552	4.05	4959	4.90	5192	5.48	4577	6.28
	35	2678	2.16	4463	3.65	4797	4.27	4988	4.67	3852	5.21
	48	2297	1.77	2454	2.51	2690	3.09	2825	3.48	2910	3.87
Min.	10	1640	3.11	2343	5.36	2602	6.84	2749	7.91	2888	9.09
	15	1570	2.92	2321	5.05	2561	6.32	2698	7.20	2704	8.45
	25	1429	2.56	2276	4.53	2480	5.44	2596	6.06	2334	7.19
	35	1288	2.23	2231	4.08	2398	4.74	2494	5.17	1965	5.96
	48	1104	1.83	1227	2.81	1345	3.43	1413	3.85	1484	4.42



AW122/12N											
Water Out(°C)		5		7		14		18		25	
Ambient Temperature(°C)		Capacity	EER	Capacity	EER	Capacity	EER	Capacity	EER	Capacity	EER
Max.	10	7718	2.56	11025	4.20	12481	5.42	13313	6.29	13712	6.90
	15	7386	2.41	10920	3.96	12285	5.01	13065	5.73	12835	6.41
	25	6723	2.11	10710	3.55	11894	4.31	12570	4.82	11081	5.46
	35	6060	1.84	10500	3.20	11502	3.75	12075	4.11	9326	4.53
	48	5198	1.51	5775	2.20	6453	2.72	6840	3.06	7046	3.36
Nom.	10	7350	2.93	10500	4.40	11886	5.83	12679	6.89	13059	7.89
	15	7034	2.75	10400	4.15	11700	5.38	12443	6.27	12224	7.33
	25	6403	2.42	10200	3.71	11327	4.64	11972	5.28	10553	6.24
	35	5771	2.10	10000	3.35	10955	4.04	11500	4.50	8882	5.17
	48	4950	1.73	5500	2.30	6146	2.92	6515	3.35	6710	3.84
Mid.	10	4013	3.10	5513	4.94	6240	6.42	6656	7.49	6856	8.31
	15	3841	2.91	5460	4.66	6143	5.93	6533	6.82	6417	7.73
	25	3496	2.56	5355	4.17	5947	5.11	6285	5.73	5540	6.57
	35	3151	2.23	5250	3.76	5751	4.45	6038	4.89	4663	5.46
	48	2703	1.83	2888	2.59	3227	3.22	3420	3.65	3523	4.05
Min.	10	1929	3.21	2756	5.52	3120	7.13	3328	8.28	3497	9.51
	15	1846	3.01	2730	5.21	3071	6.59	3266	7.54	3273	8.84
	25	1681	2.64	2678	4.66	2973	5.67	3143	6.34	2826	7.52
	35	1515	2.30	2625	4.21	2876	4.94	3019	5.41	2378	6.24
	48	1299	1.89	1444	2.89	1613	3.57	1710	4.03	1797	4.63

AW142/14N											
Water Out(°C)		5		7		14		18		25	
Ambient Temperature(°C)		Capacity	EER	Capacity	EER	Capacity	EER	Capacity	EER	Capacity	EER
Max.	10	9261	2.45	13230	4.01	14756	5.17	15628	6.01	16097	6.59
	15	8863	2.30	13104	3.78	14525	4.77	15337	5.47	15067	6.13
	25	8067	2.02	12852	3.39	14064	4.11	14756	4.60	13008	5.21
	35	7272	1.76	12600	3.05	13602	3.58	14175	3.93	10948	4.33
	48	6237	1.44	6930	2.10	7630	2.59	8030	2.93	8271	3.21
Nom.	10	8820	2.80	12600	4.20	14053	5.56	14884	6.58	15330	7.54
	15	8441	2.63	12480	3.96	13834	5.13	14607	6.00	14350	7.00
	25	7683	2.31	12240	3.55	13394	4.42	14054	5.04	12388	5.96
	35	6925	2.01	12000	3.20	12955	3.85	13500	4.30	10427	4.94
	48	5940	1.65	6600	2.20	7267	2.78	7648	3.21	7877	3.67
Mid.	10	4816	2.96	6615	4.72	7378	6.12	7814	7.16	8048	7.94
	15	4609	2.78	6552	4.45	7263	5.65	7669	6.52	7534	7.38
	25	4195	2.44	6426	3.98	7032	4.87	7378	5.48	6504	6.28
	35	3781	2.13	6300	3.59	6801	4.24	7088	4.67	5474	5.21
	48	3243	1.75	3465	2.47	3815	3.07	4015	3.48	4136	3.87
Min.	10	2315	3.06	3308	5.28	3689	6.80	3907	7.91	4105	9.09
	15	2216	2.88	3276	4.98	3631	6.28	3834	7.20	3842	8.45
	25	2017	2.53	3213	4.46	3516	5.41	3689	6.06	3317	7.19
	35	1818	2.20	3150	4.02	3401	4.71	3544	5.17	2792	5.96
	48	1559	1.80	1733	2.76	1908	3.41	2008	3.85	2109	4.42

AW162/16N											
Water Out(°C)	5		7		14		18		25		
Ambient Temperature(°C)	Capacity	EER	Capacity	EER	Capacity	EER	Capacity	EER	Capacity	EER	
Max.	10	10805	2.37	15435	3.88	17031	4.88	17943	5.59	18481	6.13
	15	10340	2.23	15288	3.66	16765	4.51	17610	5.09	17299	5.70
	25	9412	1.96	14994	3.28	16234	3.88	16942	4.28	14935	4.85
	35	8483	1.70	14700	2.96	15702	3.38	16275	3.65	12570	4.02
	48	7277	1.40	8085	2.03	8807	2.45	9220	2.72	9496	2.99
Nom.	10	10290	2.71	14700	4.07	16220	5.25	17089	6.13	17601	7.01
	15	9848	2.55	14560	3.84	15967	4.85	16771	5.58	16475	6.51
	25	8964	2.24	14280	3.44	15461	4.18	16136	4.69	14224	5.54
	35	8079	1.95	14000	3.10	14955	3.64	15500	4.00	11972	4.60
	48	6930	1.60	7700	2.13	8388	2.63	8781	2.98	9044	3.41
Mid.	10	5618	2.87	7718	4.57	8516	5.79	8972	6.66	9241	7.39
	15	5377	2.70	7644	4.31	8383	5.34	8805	6.06	8650	6.87
	25	4894	2.37	7497	3.86	8117	4.60	8471	5.10	7467	5.84
	35	4411	2.06	7350	3.48	7851	4.01	8138	4.35	6285	4.85
	48	3784	1.69	4043	2.39	4404	2.90	4610	3.24	4748	3.60
Min.	10	2701	2.97	3859	5.11	4258	6.43	4486	7.36	4713	8.45
	15	2585	2.79	3822	4.82	4191	5.93	4402	6.70	4411	7.86
	25	2353	2.45	3749	4.32	4058	5.11	4236	5.63	3808	6.69
	35	2121	2.13	3675	3.89	3926	4.45	4069	4.81	3205	5.55
	48	1819	1.75	2021	2.68	2202	3.22	2305	3.58	2422	4.12

10.2 Heating capacity

Water Out(°C) Ambient Temperature(°C)	AW042																												
	20		25		30		35		40		45		50		55		60		65		70		75		80				
	Capacity	COP	Capacity	COP	Capacity	COP	Capacity	COP	Capacity	COP	Capacity	COP	Capacity	COP	Capacity	COP	Capacity	COP	Capacity	COP	Capacity	COP	Capacity	COP	Capacity	COP			
-25	2465	2.17	2449	2.07	2433	1.96	2417	1.86	2153	1.74	1889	1.61	1626	1.49	1362	1.36	1225	1.23	1087	1.12	—	—	—	—	—	—	—	—	
-20	3003	2.66	2984	2.56	2964	2.45	2944	2.34	2653	2.17	2362	2.00	2071	1.83	1780	1.65	1590	1.47	1399	1.36	1209	1.16	—	—	—	—	—	—	
-15	3542	3.16	3519	3.04	3495	2.93	3472	2.82	3154	2.60	2836	2.39	2517	2.17	2199	1.95	1955	1.71	1711	1.58	1468	1.32	—	—	—	—	—	—	
-10	4080	3.65	4053	3.53	4027	3.42	4000	3.30	3654	3.04	3309	2.77	2963	2.51	2617	2.24	2320	1.94	2023	1.77	1727	1.47	1430	1.19	—	—	—	—	
-7	4153	3.95	4122	3.83	4091	3.71	4060	3.59	3762	3.30	3464	3.01	3166	2.71	2868	2.42	2540	2.09	2211	1.88	1882	1.56	1553	1.25	1224	1.01	—	—	
-2	4274	4.44	4236	4.32	4198	4.19	4160	4.07	3942	3.73	3723	3.39	3505	3.05	3287	2.72	2905	2.33	2523	2.04	2141	1.68	1759	1.34	1377	1.02	—	—	
2	4371	4.84	4327	4.71	4284	4.58	4240	4.46	4085	4.08	3931	3.70	3776	3.33	3622	2.95	3197	2.52	2772	2.16	2348	1.77	1923	1.41	1499	1.06	—	—	
7	4492	5.34	4441	5.20	4391	5.07	4340	4.94	4265	4.51	4190	4.09	4115	3.67	4040	3.25	3562	2.76	3085	2.30	2607	1.88	2129	1.48	1651	1.11	—	—	
12	4613	5.45	4555	5.31	4498	5.17	4440	5.04	4226	4.47	4012	3.91	3798	3.34	3584	2.78	3228	2.40	2872	2.05	2516	1.73	2160	1.44	1804	1.16	—	—	
15	4685	5.52	4624	5.38	4562	5.23	4500	5.10	4317	4.54	4135	3.98	3952	3.42	3769	2.86	3394	2.47	3020	2.11	2645	1.78	2270	1.47	1896	1.18	—	—	
20	4807	5.64	4738	5.49	4669	5.34	4600	5.20	4470	4.64	4339	4.09	4209	3.54	4078	2.99	3672	2.57	3266	2.19	2860	1.84	2454	1.52	2048	1.22	—	—	
25	—	—	4852	5.60	4776	5.44	4700	5.29	4622	4.75	4544	4.20	4465	3.65	4387	3.11	3950	2.67	3513	2.27	3075	1.90	2638	1.57	—	—	—	—	
30	—	—	—	—	4883	5.55	4800	5.39	4774	4.85	4748	4.31	4722	3.76	4696	3.22	4228	2.76	3759	2.34	3291	1.96	—	—	—	—	—	—	
35	—	—	—	—	—	—	4900	5.49	4926	4.95	4953	4.41	4979	3.87	5005	3.33	4312	2.35	3797	1.85	—	—	—	—	—	—	—	—	
-25	2280	2.26	2244	2.16	2208	2.06	2171	1.96	1966	1.83	1760	1.70	1554	1.57	1349	1.44	1210	1.31	1071	1.20	—	—	—	—	—	—	—	—	—
-20	2580	2.86	2539	2.74	2498	2.63	2457	2.51	2284	2.32	2110	2.12	1936	1.93	1763	1.73	1568	1.56	1373	1.46	1179	1.25	—	—	—	—	—	—	—
-15	2880	3.46	2834	3.32	2789	3.19	2743	3.07	2801	2.81	2460	2.55	2319	2.29	2177	2.03	1927	1.82	1676	1.70	1426	1.44	—	—	—	—	—	—	—
-10	3180	4.05	3130	3.90	3079	3.76	3029	3.62	2919	3.30	2810	2.98	2701	2.65	2591	2.33	2285	2.07	1979	1.91	1673	1.61	1367	1.31	—	—	—	—	—
-7	3360	4.41	3307	4.25	3253	4.10	3200	3.95	3110	3.59	3020	3.23	2930	2.87	2840	2.51	2500	2.22	2161	2.03	1821	1.70	1482	1.38	1142	1.06	—	—	—
-2	3660	5.01	3602	4.83	3544	4.67	3486	4.50	3428	4.08	3370	3.66	3312	3.23	3254	2.81	2859	2.47	2484	2.21	2069	1.85	1673	1.49	1278	1.13	—	—	—
2	3900	5.48	3838	5.30	3776	5.12	3714	4.95	3882	4.47	3650	4.00	3618	3.52	3586	3.05	3146	2.67	2706	2.34	2286	1.95	1826	1.57	1387	1.18	—	—	—
7	4200	6.08	4133	5.88	4067	5.69	4000	5.50	4000	4.96	4000	4.43	4000	3.89	4000	3.35	3504	2.92	3009	2.50	2513	2.08	2018	1.66	1522	1.25	—	—	—
12	4288	6.10	4219	5.91	4151	5.72	4083	5.54	4097	5.00	4111	4.47	4125	3.93	4139	3.40	3643	2.96	3147	2.54	2650	2.12	2154	1.71	1658	1.31	—	—	—
15	4340	6.11	4271	5.92	4202	5.74	4133	5.56	4156	5.03	4178	4.49	4200	3.96	4222	3.42	3726	2.99	3229	2.56	2733	2.15	2236	1.74	1740	1.34	—	—	—
20	4428	6.13	4357	5.95	4287	5.77	4217	5.60	4253	5.06	4289	4.53	4325	4.00	4361	3.46	3864	3.03	3367	2.60	2870	2.18	2373	1.78	1875	1.39	—	—	—
25	—	—	4443	5.97	4372	5.80	4300	5.63	4350	5.10	4400	4.57	4450	4.04	4500	3.51	4002	3.06	3504	2.63	3007	2.22	2509	1.82	—	—	—	—	—
30	—	—	—	—	4456	5.83	4383	5.67	4447	5.14	4511	4.61	4575	4.08	4639	3.55	4141	3.10	3642	2.67	3144	2.26	—	—	—	—	—	—	—
35	—	—	—	—	—	—	4467	5.70	4544	5.17	4622	4.64	4700	4.11	4778	3.58	4223	2.63	3679	2.11	—	—	—	—	—	—	—	—	—

Max.

Nom.

Water Out(°C) Ambient Temperature(°C)		AW042																											
		20		25		30		35		40		45		50		55		60		65		70		75		80			
		Capacity	COP	Capacity	COP	Capacity	COP	Capacity	COP	Capacity	COP	Capacity	COP	Capacity	COP	Capacity	COP	Capacity	COP	Capacity	COP	Capacity	COP	Capacity	COP	Capacity	COP		
Mid.	-25	1150	2.23	1134	2.15	1117	2.06	1101	1.98	987	1.87	873	1.77	759	1.67	645	1.57	580	1.48	515	1.43	—	—	—	—	—	—	—	—
	-20	1283	2.71	1262	2.61	1242	2.51	1221	2.40	1119	2.26	1016	2.12	914	1.98	812	1.83	729	1.72	646	1.70	564	1.56	—	—	—	—	—	—
	-15	1415	3.19	1390	3.07	1366	2.95	1341	2.83	1250	2.65	1160	2.47	1069	2.28	978	2.10	878	1.96	777	1.94	677	1.77	—	—	—	—	—	—
	-10	1547	3.67	1519	3.53	1490	3.40	1461	3.26	1382	3.04	1303	2.81	1224	2.59	1145	2.36	1027	2.20	909	2.15	790	1.95	672	1.74	—	—	—	—
	-7	1627	3.96	1595	3.81	1564	3.66	1533	3.52	1461	3.27	1389	3.02	1317	2.77	1246	2.52	1116	2.34	987	2.27	858	2.06	729	1.82	600	1.57	—	—
	-2	1759	4.44	1724	4.27	1688	4.11	1653	3.95	1593	3.66	1533	3.37	1473	3.07	1413	2.78	1265	2.58	1118	2.45	971	2.21	824	1.95	677	1.67	—	—
	2	1865	4.83	1826	4.64	1787	4.47	1749	4.29	1698	3.97	1647	3.64	1597	3.32	1546	2.99	1385	2.77	1223	2.59	1062	2.33	901	2.05	739	1.75	—	—
	7	1997	5.31	1954	5.10	1912	4.91	1869	4.72	1830	4.36	1791	3.99	1752	3.62	1713	3.25	1534	3.01	1355	2.74	1175	2.46	996	2.16	817	1.84	—	—
	12	2130	5.57	2083	5.36	2036	5.15	1989	4.95	1961	4.57	1934	4.19	1907	3.82	1880	3.44	1683	3.17	1486	2.89	1289	2.58	1091	2.26	894	1.91	—	—
	15	2209	5.73	2160	5.50	2110	5.29	2061	5.08	2041	4.70	2020	4.31	2000	3.93	1980	3.54	1772	3.26	1564	2.97	1357	2.65	1149	2.31	941	1.96	—	—
20	2341	5.98	2288	5.75	2234	5.52	2181	5.30	2172	4.90	2164	4.51	2155	4.11	2147	3.71	1921	3.41	1696	3.09	1470	2.76	1244	2.40	1018	2.02	—	—	
25	—	—	2416	5.98	2358	5.74	2301	5.51	2304	5.10	2307	4.69	2311	4.28	2314	3.86	2070	3.54	1827	3.21	1583	2.85	1340	2.48	—	—	—	—	
30	—	—	—	—	2482	5.96	2421	5.72	2436	5.29	2451	4.86	2466	4.44	2481	4.01	2219	3.67	1958	3.32	1696	2.94	—	—	—	—	—	—	
35	—	—	—	—	—	—	—	2540	5.92	2567	5.47	2594	5.03	2621	4.59	2648	4.14	2264	3.12	1978	2.62	—	—	—	—	—	—	—	
-25	598	2.37	586	2.30	574	2.24	563	2.17	502	2.07	442	1.97	381	1.88	320	1.78	289	1.71	257	1.69	—	—	—	—	—	—	—	—	
-20	665	3.02	652	2.93	639	2.84	625	2.75	572	2.58	518	2.41	464	2.24	410	2.07	368	1.97	326	1.99	283	1.85	—	—	—	—	—	—	
-15	733	3.67	718	3.55	703	3.44	688	3.32	641	3.08	594	2.84	547	2.60	500	2.35	447	2.23	394	2.26	341	2.08	—	—	—	—	—	—	
-10	801	4.31	784	4.17	768	4.04	751	3.90	711	3.59	670	3.27	630	2.96	589	2.64	526	2.49	462	2.49	399	2.28	335	2.05	—	—	—	—	
-7	841	4.70	824	4.55	806	4.40	789	4.25	752	3.89	716	3.53	680	3.17	643	2.81	573	2.65	503	2.62	434	2.39	364	2.14	294	1.85	—	—	
-2	909	5.35	890	5.17	871	5.00	852	4.83	822	4.39	792	3.96	763	3.53	733	3.10	652	2.91	572	2.81	491	2.56	411	2.28	330	1.95	—	—	
2	963	5.86	943	5.67	922	5.48	902	5.29	878	4.80	853	4.31	829	3.82	805	3.33	716	3.11	627	2.95	538	2.68	449	2.37	360	2.03	—	—	
7	1031	6.51	1009	6.29	987	6.08	965	5.87	947	5.30	929	4.74	912	4.18	894	3.62	795	3.38	695	3.11	596	2.81	496	2.48	396	2.11	—	—	
12	1098	6.79	1075	6.56	1051	6.34	1027	6.13	1017	5.54	1006	4.96	995	4.38	984	3.80	874	3.54	764	3.25	653	2.94	543	2.58	433	2.18	—	—	
15	1139	6.95	1114	6.72	1090	6.50	1065	6.28	1058	5.68	1051	5.09	1045	4.49	1038	3.90	921	3.63	805	3.33	688	3.00	572	2.64	455	2.22	—	—	
20	1207	7.21	1180	6.98	1154	6.75	1128	6.52	1128	5.90	1128	5.29	1128	4.67	1128	4.06	1000	3.77	873	3.46	746	3.11	619	2.72	492	2.29	—	—	
25	—	—	1246	7.22	1219	6.99	1191	6.75	1197	6.12	1204	5.48	1211	4.84	1217	4.20	1079	3.90	942	3.57	804	3.20	666	2.80	—	—	—	—	
30	—	—	—	—	1283	7.22	1254	6.98	1267	6.32	1280	5.66	1294	5.00	1307	4.34	1158	4.02	1010	3.67	882	3.29	—	—	—	—	—	—	
35	—	—	—	—	—	—	1316	7.20	1336	6.51	1356	5.83	1376	5.15	1397	4.46	1182	3.42	1020	2.90	—	—	—	—	—	—	—	—	

Water Out(°C) Ambient Temperature(°C)		AW062																			
		20	25	30	35	40	45	50	55	60	65	70	75	80							
		Capacity	COP	Capacity	COP	Capacity	COP	Capacity	COP	Capacity	COP	Capacity	COP	Capacity	COP						
Max.	-25	3805	2.16	3780	2.05	3755	1.95	3730	1.84	3316	1.70	2903	1.57	2489	1.44	2075	1.30	1865	1.17	1654	1.04
	-20	4576	2.68	4546	2.57	4517	2.46	4487	2.35	4039	2.16	3592	1.98	3145	1.80	2698	1.61	2406	1.43	2114	1.28
	-15	5348	3.20	5313	3.09	5278	2.97	5243	2.85	4763	2.62	4282	2.39	3801	2.16	3320	1.93	2947	1.69	2574	1.52
	-10	6120	3.72	6080	3.60	6040	3.48	6000	3.36	5486	3.08	4972	2.80	4457	2.52	3943	2.24	3489	1.95	3034	1.73
	-7	6288	4.04	6241	3.91	6193	3.78	6146	3.66	5689	3.35	5231	3.04	4774	2.73	4317	2.43	3813	2.10	3310	1.86
	-2	6569	4.56	6509	4.42	6449	4.29	6389	4.17	6027	3.81	5664	3.45	5302	3.09	4939	2.74	4355	2.36	3770	2.06
	2	6794	4.97	6724	4.84	6654	4.70	6584	4.57	6297	4.18	6011	3.78	5724	3.38	5437	2.99	4788	2.57	4138	2.21
	7	7074	5.50	6992	5.35	6910	5.21	6828	5.08	6636	4.63	6444	4.19	6252	3.74	6060	3.30	5329	2.83	4598	2.39
	12	7355	5.68	7260	5.53	7166	5.38	7071	5.24	6604	4.62	6138	4.00	5671	3.38	5205	2.76	4688	2.43	4171	2.11
	15	7523	5.79	7421	5.63	7319	5.48	7217	5.34	6780	4.71	6342	4.09	5905	3.47	5468	2.85	4924	2.51	4381	2.18
20	7804	5.97	7689	5.81	7575	5.65	7460	5.49	7072	4.87	6683	4.25	6294	3.62	5906	3.00	5318	2.64	4730	2.30	
25	—	—	7958	5.98	7831	5.81	7704	5.65	7364	5.02	7024	4.40	6684	3.77	6344	3.14	5711	2.77	5079	2.41	
30	—	—	—	—	8086	5.98	7947	5.81	7656	5.18	7364	4.54	7073	3.91	6781	3.28	6105	2.89	5428	2.51	
35	—	—	—	—	—	—	8191	5.96	7948	5.32	7705	4.69	7462	4.05	7219	3.41	6227	2.45	5483	1.98	
-25	3535	2.23	3479	2.12	3423	2.01	3367	1.90	3039	1.76	2711	1.63	2383	1.49	2055	1.35	1842	1.22	1629	1.07	
-20	3967	2.81	3904	2.68	3841	2.56	3778	2.44	3501	2.24	3225	2.05	2948	1.85	2671	1.66	2374	1.47	2076	1.32	
-15	4399	3.38	4329	3.25	4260	3.11	4190	2.98	3964	2.72	3739	2.47	3513	2.21	3288	1.96	2905	1.72	2522	1.55	
-10	4831	3.96	4755	3.81	4678	3.66	4601	3.52	4427	3.20	4253	2.89	4078	2.58	3904	2.26	3437	1.98	2969	1.76	
-7	5090	4.30	5010	4.15	4929	3.99	4848	3.84	4704	3.49	4561	3.14	4417	2.80	4274	2.45	3755	2.13	3237	1.88	
-2	5522	4.88	5435	4.71	5347	4.54	5259	4.38	5167	3.97	5075	3.57	4983	3.16	4890	2.75	4287	2.38	3684	2.07	
2	5868	5.34	5775	5.16	5682	4.98	5589	4.81	5537	4.36	5486	3.90	5435	3.45	5384	3.00	4712	2.58	4041	2.22	
7	6300	5.91	6200	5.72	6100	5.53	6000	5.35	6000	4.84	6000	4.33	6000	3.81	6000	3.30	5244	2.84	4488	2.39	
12	6563	6.05	6458	5.86	6354	5.68	6250	5.50	6229	4.96	6208	4.42	6188	3.88	6167	3.35	5415	2.88	4664	2.44	
15	6720	6.14	6613	5.95	6507	5.76	6400	5.58	6367	5.03	6333	4.48	6300	3.92	6267	3.37	5518	2.91	4770	2.47	
20	6983	6.27	6872	6.08	6761	5.90	6650	5.72	6596	5.15	6542	4.57	6488	3.99	6433	3.42	5690	2.96	4947	2.52	
25	—	—	7130	6.21	7015	6.03	6900	5.86	6825	5.26	6750	4.66	6675	4.06	6600	3.46	5862	3.00	5124	2.56	
30	—	—	—	—	7269	6.16	7150	5.99	7054	5.37	6958	4.75	6863	4.12	6767	3.50	6034	3.04	5301	2.61	
35	—	—	—	—	—	—	7400	6.12	7283	5.48	7167	4.83	7050	4.18	6933	3.54	6154	2.59	5354	2.06	
		Capacity	COP	Capacity	COP	Capacity	COP	Capacity	COP	Capacity	COP	Capacity	COP	Capacity	COP	Capacity	COP	Capacity	COP	Capacity	COP
		1874	1.34	2027	1.05	2219	1.13	2411	1.20	2526	1.24	2621	1.24	2718	1.30	2815	1.35	2912	1.40	3009	1.45
		1682	0.91	1874	0.99	2027	1.05	2219	1.13	2411	1.20	2526	1.24	2621	1.24	2718	1.30	2815	1.35	2912	1.40

AW062																												
Water Out(°C) Ambient Temperature(°C)	20		25		30		35		40		45		50		55		60		65		70		75		80			
	Capacity	COP	Capacity	COP	Capacity	COP	Capacity	COP	Capacity	COP	Capacity	COP	Capacity	COP	Capacity	COP	Capacity	COP	Capacity	COP	Capacity	COP	Capacity	COP	Capacity	COP		
-25	1812	2.25	1785	2.16	1759	2.08	1733	1.99	1544	1.87	1355	1.74	1165	1.62	976	1.50	878	1.40	780	1.33	—	—	—	—	—	—	—	—
-20	2046	2.78	2013	2.70	1980	2.61	1946	2.53	1763	2.34	1580	2.14	1396	1.95	1213	1.76	1089	1.65	966	1.59	843	1.45	—	—	—	—	—	—
-15	2281	3.32	2240	3.23	2200	3.14	2160	3.06	1982	2.80	1805	2.54	1627	2.29	1450	2.03	1301	1.90	1152	1.84	1003	1.67	—	—	—	—	—	—
-10	2515	3.85	2468	3.77	2420	3.68	2373	3.59	2201	3.27	2030	2.94	1858	2.62	1687	2.30	1512	2.15	1338	2.07	1164	1.88	990	1.68	—	—	—	—
-7	2656	4.17	2604	4.09	2553	4.00	2501	3.91	2333	3.55	2165	3.19	1997	2.82	1829	2.46	1639	2.30	1450	2.20	1260	2.00	1071	1.78	881	1.54	—	—
-2	2891	4.71	2832	4.62	2773	4.53	2714	4.44	2552	4.01	2390	3.59	2228	3.16	2066	2.73	1851	2.55	1636	2.41	1421	2.19	1206	1.95	991	1.69	—	—
2	3078	5.14	3014	5.05	2949	4.96	2885	4.87	2727	4.39	2570	3.91	2413	3.42	2255	2.94	2020	2.75	1785	2.57	1550	2.34	1314	2.08	1079	1.80	—	—
7	3313	5.67	3241	5.58	3170	5.49	3098	5.40	2946	4.85	2795	4.31	2643	3.76	2492	3.21	2231	3.00	1971	2.76	1710	2.51	1450	2.24	1189	1.93	—	—
12	3548	5.99	3469	5.87	3390	5.75	3311	5.63	3166	5.08	3020	4.52	2874	3.97	2729	3.42	2443	3.19	2157	2.95	1871	2.68	1585	2.38	1299	2.05	—	—
15	3688	6.17	3605	6.04	3522	5.90	3439	5.77	3297	5.21	3155	4.65	3013	4.09	2871	3.54	2570	3.30	2269	3.05	1967	2.77	1666	2.46	1365	2.13	—	—
20	3923	6.47	3833	6.31	3743	6.14	3652	5.98	3516	5.42	3380	4.85	3244	4.29	3108	3.73	2781	3.48	2455	3.21	2128	2.92	1801	2.60	1475	2.24	—	—
25	—	—	—	—	—	—	—	—	—	—	—	—	—	—	—	—	—	—	—	—	—	—	—	—	—	—	—	—
30	—	—	—	—	—	—	—	—	—	—	—	—	—	—	—	—	—	—	—	—	—	—	—	—	—	—	—	—
35	—	—	—	—	—	—	—	—	—	—	—	—	—	—	—	—	—	—	—	—	—	—	—	—	—	—	—	—
-25	941	2.39	923	2.33	904	2.26	886	2.19	786	2.07	685	1.94	585	1.82	485	1.69	437	1.62	389	1.57	—	—	—	—	—	—	—	—
-20	1061	3.11	1040	3.04	1019	2.97	997	2.90	901	2.67	805	2.44	709	2.22	612	1.99	549	1.89	486	1.87	423	1.73	—	—	—	—	—	—
-15	1181	3.82	1157	3.75	1133	3.67	1109	3.60	1017	3.27	924	2.94	832	2.61	740	2.28	662	2.17	583	2.15	505	1.98	—	—	—	—	—	—
-10	1301	4.53	1274	4.46	1247	4.38	1220	4.31	1132	3.87	1044	3.44	955	3.01	867	2.58	774	2.44	681	2.41	587	2.21	494	1.99	—	—	—	—
-7	1373	4.96	1345	4.88	1316	4.81	1287	4.73	1201	4.23	1115	3.74	1029	3.25	944	2.75	841	2.61	739	2.55	637	2.35	534	2.11	432	1.83	—	—
-2	1493	5.68	1462	5.59	1430	5.51	1399	5.43	1317	4.84	1235	4.24	1153	3.64	1071	3.05	954	2.88	836	2.78	719	2.55	601	2.29	484	1.98	—	—
2	1589	6.25	1556	6.16	1522	6.08	1488	5.99	1409	5.32	1330	4.64	1252	3.96	1173	3.29	1043	3.10	914	2.95	784	2.70	655	2.42	525	2.10	—	—
7	1709	6.96	1673	6.87	1636	6.79	1600	6.70	1525	5.92	1450	5.14	1375	4.36	1300	3.58	1156	3.38	1011	3.15	866	2.88	722	2.58	577	2.23	—	—
12	1829	7.30	1790	7.19	1750	7.07	1711	6.96	1640	6.16	1569	5.37	1499	4.58	1428	3.79	1268	3.57	1108	3.33	949	3.05	789	2.73	629	2.36	—	—
15	1901	7.49	1860	7.37	1819	7.24	1778	7.10	1709	6.30	1641	5.50	1573	4.70	1504	3.90	1335	3.68	1167	3.43	998	3.15	829	2.82	660	2.43	—	—
20	2021	7.81	1977	7.65	1933	7.50	1889	7.34	1825	6.53	1760	5.72	1696	4.90	1632	4.09	1448	3.86	1264	3.60	1080	3.30	896	2.95	712	2.55	—	—
25	—	—	—	—	—	—	—	—	—	—	—	—	—	—	—	—	—	—	—	—	—	—	—	—	—	—	—	—
30	—	—	—	—	—	—	—	—	—	—	—	—	—	—	—	—	—	—	—	—	—	—	—	—	—	—	—	—
35	—	—	—	—	—	—	—	—	—	—	—	—	—	—	—	—	—	—	—	—	—	—	—	—	—	—	—	—



Water Out(°C) Ambient Temperature(°C)	20		25		30		35		40		45		50		55		60		65		70		75		80		
	Capacity	COP	Capacity	COP	Capacity	COP	Capacity	COP	Capacity	COP	Capacity	COP	Capacity	COP	Capacity	COP	Capacity	COP	Capacity	COP	Capacity	COP	Capacity	COP	Capacity	COP	
-25	5144	2.16	5111	2.08	5077	1.99	5043	1.91	4395	1.80	3747	1.69	3099	1.57	2451	1.46	2198	1.35	1946	0.97	—	—	—	—	—	—	—
-20	6149	2.69	6109	2.59	6069	2.50	6029	2.41	5353	2.24	4677	2.08	4000	1.91	3324	1.75	2956	1.59	2587	1.24	2219	1.07	—	—	—	—	—
-15	7155	3.21	7108	3.11	7061	3.01	7014	2.91	6310	2.69	5606	2.47	4902	2.25	4198	2.03	3713	1.82	3229	1.50	2745	1.27	—	—	—	—	—
-10	8160	3.74	8107	3.62	8053	3.51	8000	3.40	7268	3.13	6535	2.86	5803	2.59	5071	2.32	4471	2.06	3870	1.74	3270	1.46	2670	1.19	—	—	—
-7	8385	4.05	8321	3.93	8258	3.82	8195	3.70	7545	3.40	6895	3.10	6245	2.79	5595	2.49	4925	2.20	4255	1.87	3586	1.57	2916	1.28	2246	1.03	—
-2	8759	4.58	8679	4.45	8599	4.32	8519	4.20	8006	3.84	7494	3.49	6981	3.13	6468	2.77	5882	2.44	4997	2.09	4111	1.74	3325	1.41	2540	1.07	—
2	9058	4.99	8965	4.86	8872	4.73	8779	4.60	8376	4.20	7973	3.80	7570	3.40	7167	3.00	6288	2.62	5410	2.25	4532	1.87	3653	1.50	2775	1.14	—
7	9432	5.52	9323	5.38	9213	5.24	9103	5.10	8838	4.65	8572	4.19	8306	3.74	8040	3.28	7046	2.86	6051	2.44	5057	2.03	4063	1.62	3069	1.22	—
12	9806	5.70	9680	5.55	9554	5.40	9428	5.26	8769	4.62	8109	3.98	7450	3.34	6791	2.70	6105	2.41	5419	2.12	4734	1.84	4048	1.56	3362	1.29	—
15	10031	5.81	9895	5.65	9759	5.50	9623	5.35	9006	4.72	8389	4.08	7772	3.44	7155	2.80	6432	2.50	5709	2.20	4985	1.91	4262	1.62	3539	1.33	—
20	10405	5.98	10252	5.82	10100	5.66	9947	5.51	9401	4.87	8855	4.24	8309	3.60	7763	2.96	6977	2.64	6191	2.32	5405	2.01	4619	1.70	3833	1.40	—
25	—	—	10610	5.99	10441	5.82	10272	5.66	9797	5.03	9322	4.39	8846	3.75	8371	3.12	7522	2.77	6673	2.43	5824	2.10	4975	1.78	—	—	—
30	—	—	—	—	10782	5.98	10596	5.82	10192	5.18	9788	4.54	9384	3.90	8979	3.26	8067	2.90	7156	2.54	6244	2.19	—	—	—	—	—
35	—	—	—	—	—	—	10921	5.97	10587	5.33	10254	4.69	9921	4.04	9587	3.40	8229	2.46	7227	2.01	—	—	—	—	—	—	—
-25	4790	2.23	4714	2.14	4638	2.05	4562	1.97	4029	1.85	3496	1.74	2963	1.62	2430	1.51	2175	1.40	1919	1.01	—	—	—	—	—	—	—
-20	5354	2.81	5269	2.70	5184	2.60	5099	2.49	4650	2.32	4200	2.15	3750	1.98	3300	1.80	2925	1.64	2549	1.29	2173	1.09	—	—	—	—	—
-15	5918	3.38	5824	3.26	5731	3.14	5637	3.02	5270	2.79	4904	2.56	4537	2.33	4171	2.10	3674	1.88	3178	1.55	2682	1.30	—	—	—	—	—
-10	6482	3.96	6380	3.82	6277	3.68	6174	3.55	5891	3.26	5607	2.97	5324	2.68	5041	2.39	4424	2.12	3808	1.79	3191	1.49	2574	1.20	—	—	—
-7	6821	4.30	6713	4.15	6604	4.01	6496	3.87	6263	3.54	6030	3.22	5796	2.90	5563	2.57	4874	2.27	4185	1.93	3496	1.60	2807	1.28	2118	0.96	—
-2	7385	4.88	7268	4.71	7150	4.55	7033	4.40	6883	4.02	6733	3.63	6583	3.25	6433	2.87	5624	2.51	4815	2.14	4005	1.77	3196	1.41	2387	1.04	—
2	7836	5.34	7712	5.16	7587	4.99	7463	4.82	7380	4.39	7296	3.96	7213	3.53	7130	3.10	6224	2.70	5318	2.31	4413	1.90	3507	1.50	2601	1.11	—
7	8400	5.91	8267	5.72	8133	5.53	8000	5.35	8000	4.86	8000	4.38	8000	3.89	8000	3.40	6974	2.95	5948	2.50	4922	2.06	3895	1.62	2869	1.18	—
12	8750	6.05	8611	5.86	8472	5.68	8333	5.50	8306	4.98	8278	4.47	8250	3.96	8222	3.45	7205	2.99	6188	2.55	5171	2.11	4154	1.68	3137	1.26	—
15	8960	6.14	8818	5.95	8676	5.76	8533	5.58	8489	5.06	8444	4.53	8400	4.00	8356	3.47	7344	3.02	6333	2.57	5321	2.14	4310	1.71	3298	1.30	—
20	9310	6.27	9162	6.08	9014	5.90	8867	5.72	8794	5.17	8722	4.62	8650	4.07	8578	3.52	7576	3.06	6573	2.62	5571	2.19	4569	1.77	3566	1.36	—
25	—	—	9507	6.21	9353	6.03	9200	5.86	9100	5.29	9000	4.71	8900	4.14	8800	3.56	7807	3.10	6814	2.66	5821	2.23	4828	1.82	—	—	—
30	—	—	—	—	9692	6.16	9533	5.99	9406	5.40	9278	4.80	9150	4.20	9022	3.60	8038	3.14	7054	2.70	6071	2.28	—	—	—	—	—
35	—	—	—	—	—	—	9867	6.12	9711	5.50	9556	4.88	9400	4.26	9244	3.65	8199	2.67	7125	2.13	—	—	—	—	—	—	—

Max.

Nom.

Water Out(°C) Ambient Temperature(°C)		AW082																															
		20	25	30	35	40	45	50	55	60	65	70	75	80																			
		Capacity	COP	Capacity	COP	Capacity	COP	Capacity	COP	Capacity	COP	Capacity	COP	Capacity	COP																		
Mid.	-25	2456	2.25	2421	2.18	2386	2.11	2350	2.04	2048	1.92	1746	1.81	1443	1.70	1141	1.58	1026	1.51	911	1.21	—	—	—	—								
	-20	2766	2.79	2721	2.71	2677	2.64	2632	2.57	2341	2.38	2050	2.20	1759	2.01	1468	1.83	1318	1.73	1167	1.50	1016	1.40	—	—	—	—						
	-15	3076	3.33	3022	3.25	2967	3.17	2913	3.10	2634	2.84	2355	2.58	2075	2.32	1796	2.07	1610	1.96	1423	1.77	1236	1.64	—	—	—	—						
	-10	3386	3.87	3322	3.79	3258	3.71	3195	3.63	2927	3.30	2659	2.97	2391	2.64	2124	2.31	1901	2.18	1679	2.02	1457	1.87	1235	1.70	—	—	—	—				
	-7	3572	4.19	3502	4.11	3433	4.03	3363	3.95	3103	3.57	2842	3.20	2581	2.83	2320	2.45	2077	2.32	1833	2.16	1589	2.00	1345	1.82	1102	1.60	—	—	—	—		
	-2	3881	4.73	3803	4.65	3724	4.56	3645	4.48	3396	4.03	3146	3.58	2897	3.14	2648	2.69	2369	2.55	2089	2.39	1810	2.20	1530	2.00	1251	1.76	—	—	—	—		
	2	4129	5.16	4043	5.07	3956	4.99	3870	4.90	3630	4.40	3390	3.89	3150	3.39	2910	2.89	2602	2.73	2294	2.56	1986	2.36	1678	2.13	1370	1.87	—	—	—	—		
	7	4439	5.70	4343	5.61	4247	5.52	4151	5.43	3923	4.86	3695	4.28	3466	3.70	3238	3.13	2894	2.95	2550	2.76	2206	2.54	1863	2.29	1519	2.01	—	—	—	—		
	12	4749	6.01	4643	5.89	4538	5.78	4433	5.66	4216	5.08	3999	4.50	3782	3.93	3565	3.35	3186	3.16	2806	2.95	2427	2.71	2047	2.44	1668	2.13	—	—	—	—		
	15	4935	6.19	4824	6.06	4713	5.92	4602	5.79	4392	5.21	4182	4.63	3972	4.06	3762	3.48	3361	3.28	2960	3.06	2559	2.81	2158	2.53	1757	2.20	—	—	—	—		
20	5244	6.49	5124	6.32	5004	6.16	4883	6.00	4685	5.42	4486	4.84	4288	4.26	4090	3.68	3653	3.47	3216	3.23	2780	2.96	2343	2.66	1906	2.32	—	—	—	—			
25	—	—	5424	6.58	5294	6.39	5164	6.20	4978	5.62	4791	5.04	4604	4.46	4417	3.88	3945	3.65	3473	3.40	3000	3.11	2528	2.79	—	—	—	—	—	—			
30	—	—	—	—	5585	6.61	5446	6.39	5271	5.81	5095	5.22	4920	4.64	4745	4.06	4237	3.82	3729	3.55	3221	3.25	—	—	—	—	—	—	—	—			
35	—	—	—	—	—	—	—	5727	6.57	5564	5.99	5400	5.40	5236	4.82	5073	4.24	4322	3.25	3766	2.81	—	—	—	—	—	—	—	—	—	—		
Min.	-25	1276	2.39	1251	2.34	1226	2.28	1201	2.22	1043	2.10	885	1.97	726	1.85	568	1.73	511	1.67	455	1.43	—	—	—	—	—	—	—	—	—	—		
	-20	1434	3.11	1406	3.05	1377	2.99	1349	2.92	1197	2.69	1046	2.46	895	2.24	744	2.01	666	1.93	588	1.77	511	1.67	—	—	—	—	—	—	—	—		
	-15	1593	3.83	1560	3.76	1528	3.70	1496	3.63	1352	3.29	1207	2.96	1063	2.62	919	2.28	821	2.19	722	2.07	623	1.95	—	—	—	—	—	—	—	—	—	
	-10	1751	4.55	1715	4.48	1679	4.41	1643	4.33	1506	3.89	1369	3.45	1232	3.00	1095	2.56	975	2.45	866	2.35	736	2.20	616	2.01	—	—	—	—	—	—	—	
	-7	1846	4.98	1808	4.91	1770	4.83	1731	4.76	1598	4.25	1466	3.74	1333	3.23	1200	2.72	1068	2.60	936	2.50	804	2.34	671	2.14	539	1.90	—	—	—	—	—	—
	-2	2005	5.70	1963	5.62	1921	5.54	1878	5.46	1753	4.85	1627	4.23	1502	3.62	1376	3.00	1223	2.86	1069	2.75	916	2.56	763	2.33	610	2.06	—	—	—	—	—	—
	2	2132	6.28	2087	6.19	2041	6.11	1996	6.03	1876	5.32	1756	4.62	1636	3.92	1516	3.22	1346	3.07	1176	2.93	1006	2.72	836	2.47	666	2.18	—	—	—	—	—	—
	7	2290	6.99	2241	6.91	2192	6.82	2143	6.73	2031	5.92	1918	5.11	1805	4.30	1692	3.50	1501	3.33	1310	3.14	1119	2.91	928	2.64	736	2.31	—	—	—	—	—	—
	12	2449	7.33	2396	7.21	2343	7.10	2291	6.98	2185	6.17	2079	5.35	1973	4.54	1868	3.72	1656	3.54	1443	3.33	1231	3.08	1019	2.79	807	2.44	—	—	—	—	—	—
	15	2544	7.52	2489	7.39	2434	7.26	2379	7.13	2277	6.31	2176	5.49	2075	4.67	1973	3.85	1748	3.66	1524	3.44	1299	3.18	1074	2.88	849	2.51	—	—	—	—	—	—
20	2703	7.83	2644	7.68	2585	7.52	2526	7.36	2432	6.53	2337	5.70	2243	4.88	2149	4.05	1903	3.85	1657	3.61	1411	3.34	1166	3.02	920	2.63	—	—	—	—	—	—	
25	—	—	2798	7.95	2736	7.76	2673	7.58	2586	6.74	2499	5.91	2412	5.07	2324	4.23	2058	4.02	1791	3.78	1524	3.49	1257	3.15	—	—	—	—	—	—	—	—	
30	—	—	—	—	2887	8.00	2820	7.79	2740	6.94	2660	6.10	2580	5.25	2500	4.41	2212	4.18	1924	3.93	1637	3.62	—	—	—	—	—	—	—	—	—	—	
35	—	—	—	—	—	—	2968	7.98	2895	7.13	2822	6.28	2749	5.43	2676	4.57	2256	4.57	1944	3.10	—	—	—	—	—	—	—	—	—	—	—	—	—

Water Out(°C) Ambient Temperature(°C)		20		25		30		35		40		45		50		55		60		65		70		75		80			
		Capacity	COP	Capacity	COP	Capacity	COP	Capacity	COP	Capacity	COP	Capacity	COP	Capacity	COP	Capacity	COP	Capacity	COP	Capacity	COP	Capacity	COP	Capacity	COP	Capacity	COP		
Max.		-25	6609	2.12	6566	2.05	6522	1.98	6479	1.91	5622	1.82	4764	1.72	3907	1.63	3050	1.53	2736	1.44	2422	0.99	—	—	—	—	—	—	
		-20	7806	2.62	7755	2.54	7704	2.46	7653	2.38	6777	2.23	5902	2.09	5027	1.94	4151	1.80	3692	1.65	3233	1.26	2775	1.08	—	—	—	—	—
		-15	9003	3.11	8944	3.02	8885	2.93	8826	2.84	7933	2.65	7040	2.45	6146	2.26	5253	2.06	4649	1.87	4045	1.51	3441	1.28	—	—	—	—	—
		-10	10200	3.61	10133	3.51	10067	3.41	10000	3.31	9089	3.07	8177	2.82	7266	2.58	6354	2.33	5606	2.08	4857	1.74	4108	1.47	3359	1.19	—	—	—
		-7	10481	3.91	10402	3.80	10322	3.70	10243	3.59	9436	3.32	8629	3.04	7822	2.76	7015	2.49	6179	2.21	5343	1.87	4507	1.57	3671	1.27	2835	1.02	—
		-2	10948	4.41	10849	4.29	10749	4.17	10649	4.06	10016	3.73	9383	3.41	8750	3.08	8117	2.75	7136	2.43	6155	2.07	5174	1.73	4193	1.39	3212	1.06	—
		2	11323	4.81	11206	4.68	11090	4.56	10974	4.43	10480	4.07	9986	3.70	9492	3.33	8998	2.97	7901	2.60	6804	2.22	5707	1.85	4610	1.48	3513	1.12	—
		7	11790	5.30	11653	5.17	11516	5.03	11379	4.90	11059	4.48	10740	4.07	10420	3.65	10100	3.23	8858	2.81	7616	2.40	6374	1.99	5132	1.59	3890	1.20	—
		12	12258	5.47	12100	5.33	11943	5.19	11785	5.05	10874	4.42	9963	3.78	9052	3.15	8142	2.52	7366	2.26	6591	2.00	5816	1.75	5041	1.51	4266	1.26	—
		15	12639	5.57	12369	5.42	12198	5.28	12028	5.14	11164	4.50	10301	3.87	9437	3.24	8573	2.60	7757	2.33	6941	2.07	6124	1.81	5308	1.55	4492	1.30	—
20	13006	5.73	12816	5.58	12625	5.43	12434	5.28	11648	4.64	10863	4.01	10078	3.37	9292	2.73	8407	2.45	7523	2.17	6638	1.89	5753	1.62	4868	1.36	—		
25	—	—	13263	5.73	13051	5.58	12840	5.42	12133	4.78	11425	4.14	10718	3.50	10011	2.86	9058	2.56	8105	2.26	7151	1.97	6198	1.69	—	—	—		
30	—	—	—	—	13477	5.72	13245	5.56	12617	4.91	11988	4.27	11359	3.62	10730	2.97	9708	2.66	8687	2.35	7665	2.05	—	—	—	—	—		
35	—	—	—	—	—	—	13651	5.70	13101	5.05	12550	4.39	12000	3.74	11449	3.08	9903	2.26	8774	1.86	—	—	—	—	—	—	—		
Nom.		-25	6180	2.18	6082	2.11	5984	2.03	5886	1.96	5169	1.86	4453	1.76	3736	1.66	3019	1.56	2702	1.46	2384	1.00	—	—	—	—	—	—	
		-20	6855	2.72	6746	2.63	6637	2.54	6529	2.45	5924	2.29	5319	2.13	4715	1.97	4110	1.81	3642	1.67	3173	1.27	2704	1.08	—	—	—	—	—
		-15	7530	3.26	7410	3.15	7291	3.04	7171	2.94	6679	2.72	6186	2.51	5694	2.29	5201	2.07	4581	1.88	3962	1.51	3342	1.27	—	—	—	—	—
		-10	8205	3.80	8075	3.67	7945	3.55	7814	3.43	7434	3.15	7053	2.88	6672	2.60	6292	2.33	5521	2.08	4751	1.74	3980	1.45	3210	1.17	—	—	—
		-7	8610	4.12	8473	3.99	8337	3.85	8200	3.73	7887	3.41	7573	3.10	7260	2.79	6946	2.48	6085	2.21	5224	1.86	4363	1.55	3502	1.24	2641	0.93	—
		-2	9285	4.66	9138	4.51	8990	4.36	8843	4.22	8641	3.85	8440	3.48	8238	3.11	8037	2.74	7025	2.41	6013	2.06	5001	1.71	3989	1.36	2977	1.01	—
		2	9825	5.10	9669	4.93	9513	4.77	9357	4.61	9245	4.19	9133	3.78	9021	3.36	8909	2.94	7777	2.58	6644	2.20	5511	1.82	4378	1.45	3245	1.07	—
		7	10500	5.64	10333	5.45	10167	5.27	10000	5.10	10000	4.63	10000	4.15	10000	3.68	10000	3.20	8716	2.79	7433	2.37	6149	1.96	4865	1.55	3581	1.14	—
		12	10838	5.77	10764	5.59	10690	5.41	10617	5.24	10382	4.74	10347	4.24	10313	3.74	10278	3.24	9006	2.83	7734	2.41	6461	2.01	5189	1.60	3917	1.20	—
		15	11200	5.85	11022	5.67	10844	5.49	10667	5.32	10611	4.81	10556	4.30	10500	3.78	10444	3.27	9179	2.85	7914	2.44	6649	2.03	5384	1.63	4119	1.24	—
20	11638	5.97	11453	5.80	11268	5.62	11083	5.46	10993	4.92	10903	4.38	10813	3.85	10722	3.31	9469	2.89	8215	2.48	6962	2.07	5708	1.68	4455	1.30	—		
25	—	—	11883	5.92	11692	5.75	11500	5.59	11375	5.03	11250	4.47	11125	3.91	11000	3.35	9758	2.93	8516	2.51	7274	2.11	6033	1.73	—	—	—		
30	—	—	—	—	12115	5.88	11917	5.71	11757	5.13	11597	4.55	11438	3.97	11278	3.39	10048	2.96	8817	2.55	7587	2.15	—	—	—	—	—		
35	—	—	—	—	—	—	12333	5.84	12139	5.23	11944	4.63	11750	4.03	11556	3.43	10248	2.52	8905	2.01	—	—	—	—	—	—	—		

Water Out(°C) Ambient Temperature(°C)		20		25		30		35		40		45		50		55		60		65		70		75		80				
		Capacity	COP	Capacity	COP	Capacity	COP	Capacity	COP	Capacity	COP	Capacity	COP	Capacity	COP	Capacity	COP	Capacity	COP	Capacity	COP	Capacity	COP	Capacity	COP	Capacity	COP			
Mid.		-25	3173	2.20	3128	2.17	3082	2.14	3036	2.12	2628	2.05	2220	1.98	1811	1.91	1403	1.84	1263	1.80	1124	1.23	—	—	—	—	—	—		
		-20	3553	2.71	3496	2.68	3438	2.64	3381	2.60	2983	2.45	2586	2.31	2189	2.16	1791	2.01	1612	1.96	1433	1.50	1253	1.40	—	—	—	—	—	
		-15	3932	3.23	3863	3.18	3794	3.14	3726	3.09	3339	2.86	2952	2.64	2566	2.41	2179	2.18	1960	2.11	1742	1.75	1523	1.63	—	—	—	—	—	
		-10	4312	3.74	4231	3.69	4151	3.63	4070	3.58	3694	3.27	3318	2.96	2943	2.66	2567	2.35	2309	2.26	2051	1.97	1793	1.84	1535	1.68	—	—	—	
		-7	4540	4.05	4452	3.99	4364	3.93	4277	3.87	3907	3.51	3538	3.16	3169	2.81	2799	2.46	2518	2.36	2236	2.10	1955	1.95	1673	1.79	1391	1.60	—	
		-2	4920	4.56	4820	4.49	4721	4.42	4621	4.35	4263	3.92	3904	3.49	3546	3.06	3187	2.63	2866	2.51	2545	2.30	2224	2.14	1903	1.95	1582	1.74	—	
		2	5223	4.97	5115	4.90	5006	4.82	4897	4.74	4547	4.25	4197	3.75	3847	3.26	3498	2.77	3145	2.63	2792	2.45	2440	2.27	2087	2.08	1735	1.85	—	
		7	5603	5.49	5463	5.40	5362	5.32	5241	5.23	4902	4.66	4563	4.08	4224	3.51	3885	2.94	3493	2.79	3102	2.62	2710	2.43	2318	2.22	1926	1.97	—	
		12	5983	5.77	5851	5.66	5718	5.55	5586	5.44	5258	4.86	4930	4.28	4601	3.70	4273	3.12	3842	2.96	3411	2.78	2979	2.58	2548	2.35	2117	2.09	—	
		15	6211	5.94	6071	5.81	5932	5.69	5793	5.56	5471	4.97	5149	4.39	4828	3.81	4506	3.23	4051	3.06	3596	2.87	3141	2.66	2686	2.43	2231	2.16	—	
		20	6590	6.22	6439	6.06	6288	5.90	6137	5.75	5826	5.16	5516	4.57	5205	3.98	4894	3.40	4399	3.22	3905	3.02	3411	2.80	2916	2.54	2422	2.26	—	
		25	—	—	6807	6.30	6644	6.11	6482	5.93	6182	5.34	5882	4.74	5582	4.15	5282	3.55	4748	3.36	4214	3.15	3680	2.92	3147	2.65	—	—	—	
		30	—	—	—	—	—	7001	6.32	6826	6.10	6537	5.50	6248	4.90	5959	4.30	5670	3.70	5096	3.50	4523	3.28	3950	3.04	—	—	—	—	—
		35	—	—	—	—	—	—	—	7171	6.27	6892	5.66	6614	5.06	6336	4.45	6057	3.84	5198	2.98	4568	2.59	—	—	—	—	—	—	—
		-25	1648	2.34	1616	2.32	1584	2.29	1552	2.26	1338	2.17	1125	2.09	912	2.00	698	1.91	630	1.88	561	1.45	—	—	—	—	—	—	—	
-20	1842	3.03	1806	2.99	1769	2.96	1732	2.92	1526	2.72	1319	2.52	1113	2.32	906	2.12	814	2.07	722	1.76	630	1.67	—	—	—	—	—			
-15	2037	3.72	1995	3.67	1954	3.63	1913	3.58	1713	3.27	1513	2.96	1314	2.65	1114	2.34	999	2.27	883	2.04	767	1.92	—	—	—	—	—			
-10	2231	4.40	2185	4.35	2139	4.29	2093	4.24	1900	3.82	1708	3.39	1515	2.97	1322	2.55	1183	2.47	1044	2.29	905	2.15	766	1.99	—	—	—			
-7	2347	4.81	2299	4.75	2250	4.70	2201	4.63	2013	4.15	1824	3.66	1636	3.17	1447	2.68	1294	2.58	1141	2.42	987	2.28	834	2.10	681	1.89	—			
-2	2542	5.50	2488	5.43	2435	5.36	2381	5.29	2200	4.69	2018	4.09	1837	3.49	1655	2.89	1478	2.78	1302	2.64	1125	2.47	948	2.27	771	2.04	—			
2	2697	6.05	2640	5.97	2583	5.90	2526	5.82	2350	5.13	2174	4.44	1998	3.75	1822	3.06	1626	2.94	1430	2.79	1235	2.61	1039	2.40	843	2.15	—			
7	2891	6.73	2829	6.65	2768	6.57	2706	6.48	2537	5.68	2368	4.88	2199	4.08	2030	3.27	1811	3.13	1591	2.97	1372	2.78	1153	2.55	933	2.27	—			
12	3085	7.04	3019	6.93	2953	6.82	2886	6.71	2724	5.90	2562	5.08	2400	4.27	2238	3.46	1995	3.31	1752	3.13	1509	2.93	1267	2.68	1024	2.39	—			
15	3202	7.22	3133	7.09	3064	6.97	2994	6.84	2836	6.02	2679	5.20	2521	4.38	2363	3.56	2106	3.40	1849	3.22	1592	3.01	1335	2.76	1078	2.45	—			
20	3396	7.51	3322	7.36	3248	7.21	3175	7.06	3024	6.22	2873	5.39	2722	4.56	2571	3.72	2290	3.56	2010	3.37	1729	3.14	1449	2.88	1168	2.56	—			
25	—	—	—	—	—	3512	7.61	3433	7.43	3355	7.25	3211	6.41	3067	5.56	2923	4.72	2779	3.87	2475	3.70	2171	3.50	1867	3.26	1563	2.98	—		
30	—	—	—	—	—	—	—	3618	7.64	3535	7.44	3398	6.59	3261	5.73	3124	4.87	2987	4.01	2659	3.83	2332	3.62	2004	3.38	—	—	—		
35	—	—	—	—	—	—	—	—	—	3716	7.62	3585	6.75	3455	5.88	3325	5.01	3195	4.14	2713	3.25	2355	2.86	—	—	—	—	—		



Water Out(°C) Ambient Temperature(°C)		AW122/AW12N																											
		20		25		30		35		40		45		50		55		60		65		70		75		80			
		Capacity	COP	Capacity	COP	Capacity	COP	Capacity	COP	Capacity	COP	Capacity	COP	Capacity	COP	Capacity	COP	Capacity	COP	Capacity	COP	Capacity	COP	Capacity	COP	Capacity	COP	Capacity	COP
-25		7395	2.05	7347	1.98	7298	1.91	7250	1.84	6549	1.75	5948	1.66	5148	1.57	4447	1.48	4007	1.38	3567	1.13	—	—	—	—	—	—	—	—
-20		9010	2.51	8951	2.42	8892	2.34	8833	2.27	8017	2.14	7200	2.01	6384	1.88	5567	1.75	4984	1.60	4402	1.36	3820	1.17	—	—	—	—	—	—
-15		10625	2.96	10566	2.87	10486	2.78	10417	2.69	9484	2.52	8552	2.36	7619	2.19	6687	2.02	5962	1.83	5237	1.57	4513	1.35	—	—	—	—	—	—
-10		12240	3.41	12180	3.31	12080	3.22	12000	3.12	10952	2.91	9903	2.71	8855	2.50	7807	2.29	6940	2.05	6073	1.78	5205	1.51	4338	1.25	—	—	—	—
-7		12577	3.68	12482	3.58	12387	3.48	12292	3.38	11339	3.15	10386	2.92	9432	2.68	8479	2.45	7526	2.18	6574	1.90	5621	1.61	4688	1.33	3716	1.05	—	—
-2		13138	4.14	13018	4.02	12899	3.91	12779	3.81	11984	3.53	11189	3.26	10394	2.99	9599	2.72	8504	2.40	7409	2.08	6314	1.76	5219	1.44	4124	1.13	—	—
2		13587	4.50	13447	4.38	13308	4.26	13168	4.15	12500	3.85	11832	3.54	11163	3.24	10495	2.94	9286	2.58	8077	2.23	6868	1.87	5659	1.53	4450	1.19	—	—
7		14148	4.95	13984	4.82	13820	4.70	13655	4.57	13145	4.23	12635	3.89	12125	3.55	11615	3.21	10264	2.80	8912	2.40	7561	2.01	6210	1.63	4859	1.26	—	—
12		14710	5.16	14520	5.02	14331	4.89	14142	4.76	13156	4.26	12171	3.76	11186	3.26	10200	2.76	9214	2.46	8227	2.17	7240	1.88	6253	1.60	5267	1.33	—	—
15		15046	5.28	14842	5.14	14638	5.00	14434	4.87	13496	4.37	12558	3.86	11620	3.36	10682	2.86	9648	2.54	8614	2.24	7580	1.94	6546	1.65	5512	1.37	—	—
20		15608	5.49	15379	5.34	15150	5.19	14921	5.05	14062	4.54	13203	4.03	12344	3.53	11485	3.02	10372	2.68	9259	2.35	8146	2.04	7033	1.73	5920	1.43	—	—
25		—	—	15915	5.54	15661	5.39	15408	5.24	14628	4.72	13848	4.20	13068	3.69	12289	3.17	11096	2.81	9904	2.46	8712	2.13	7520	1.80	—	—	—	—
30		—	—	—	—	16173	5.58	15894	5.42	15194	4.90	14493	4.37	13792	3.84	13092	3.31	11821	2.93	10549	2.57	9278	2.21	—	—	—	—	—	—
35		—	—	—	—	—	—	16381	5.61	15760	5.07	15138	4.53	14516	3.99	13895	3.45	12057	2.49	10655	2.03	—	—	—	—	—	—	—	—
-25		6840	2.14	6731	2.06	6623	1.99	6514	1.91	5986	1.81	5459	1.71	4931	1.61	4403	1.51	3953	1.41	3503	1.15	—	—	—	—	—	—	—	—
-20		7740	2.69	7617	2.59	7494	2.50	7371	2.41	6907	2.25	6442	2.10	5977	1.94	5512	1.79	4910	1.63	4308	1.38	3706	1.18	—	—	—	—	—	—
-15		8640	3.23	8503	3.12	8366	3.01	8229	2.91	7827	2.70	7425	2.49	7023	2.28	6621	2.07	5867	1.86	5113	1.59	4359	1.35	—	—	—	—	—	—
-10		9540	3.78	9389	3.65	9237	3.53	9086	3.41	8747	3.14	8408	2.88	8069	2.61	7730	2.35	6824	2.08	5918	1.80	5012	1.51	4106	1.22	—	—	—	—
-7		10080	4.11	9920	3.97	9760	3.84	9600	3.70	9299	3.41	8998	3.11	8696	2.81	8395	2.52	7398	2.22	6401	1.92	5404	1.60	4407	1.29	3410	0.99	—	—
-2		10980	4.65	10806	4.50	10631	4.35	10457	4.20	10219	3.85	9981	3.50	9742	3.15	9504	2.80	8355	2.45	7206	2.10	6057	1.75	4908	1.40	3759	1.06	—	—
2		11700	5.09	11514	4.92	11329	4.76	11143	4.60	10955	4.21	10767	3.81	10579	3.42	10391	3.02	9120	2.63	7850	2.25	6579	1.86	5308	1.48	4038	1.12	—	—
7		12600	5.64	12400	5.45	12200	5.27	12000	5.10	11875	4.65	11750	4.20	11625	3.75	11500	3.30	10077	2.85	8655	2.42	7232	2.00	5809	1.58	4387	1.18	—	—
12		13350	5.87	13067	5.65	12783	5.44	12500	5.24	12330	4.77	12160	4.29	11990	3.82	11819	3.35	10403	2.90	8986	2.47	7569	2.05	6153	1.64	4736	1.24	—	—
15		13800	6.01	13467	5.77	13133	5.54	12800	5.32	12603	4.83	12406	4.35	12208	3.86	12011	3.37	10598	2.92	9185	2.49	7772	2.08	6358	1.67	4945	1.28	—	—
20		14550	6.23	14133	5.96	13717	5.70	13300	5.46	13058	4.95	12815	4.44	12573	3.93	12331	3.42	10923	2.97	9516	2.54	8109	2.12	6702	1.72	5294	1.34	—	—
25		—	—	14800	6.15	14300	5.86	13800	5.59	13513	5.05	13225	4.52	12938	3.99	12650	3.46	11249	3.01	9847	2.58	8446	2.17	7045	1.77	—	—	—	—
30		—	—	—	—	14883	6.02	14300	5.71	13967	5.16	13635	4.61	13302	4.05	12969	3.50	11574	3.05	10179	2.62	8783	2.21	—	—	—	—	—	—
35		—	—	—	—	—	—	14800	5.84	14422	5.26	14044	4.69	13667	4.11	13289	3.54	11806	2.59	10280	2.07	—	—	—	—	—	—	—	—

Max.

Nom.

Water Out(°C) Ambient Temperature(°C)		20		25		30		35		40		45		50		55		60		65		70		75		80			
		Capacity	COP	Capacity	COP	Capacity	COP	Capacity	COP	Capacity	COP	Capacity	COP	Capacity	COP	Capacity	COP	Capacity	COP	Capacity	COP	Capacity	COP	Capacity	COP	Capacity	COP		
Mid.		-25	3500	2.15	3449	2.07	3399	1.99	3348	1.91	3039	1.82	2730	1.72	2421	1.63	2111	1.53	1902	1.46	1693	1.44	—	—	—	—	—	—	
		-20	3978	2.65	3913	2.55	3848	2.45	3783	2.36	3474	2.22	3166	2.08	2857	1.94	2548	1.80	2293	1.70	2038	1.69	1784	1.58	—	—	—	—	—
		-15	4456	3.15	4377	3.03	4298	2.91	4218	2.80	3910	2.61	3601	2.43	3293	2.24	2984	2.06	2684	1.95	2383	1.92	2083	1.79	—	—	—	—	—
		-10	4935	3.65	4841	3.51	4747	3.37	4654	3.24	4345	3.01	4037	2.78	3729	2.55	3420	2.32	3074	2.19	2729	2.15	2383	1.99	2037	1.82	—	—	—
		-7	5222	3.95	5119	3.80	5017	3.65	4915	3.50	4607	3.25	4298	2.99	3990	2.73	3682	2.47	3309	2.34	2936	2.28	2562	2.11	2189	1.92	1816	1.70	—
		-2	5700	4.45	5583	4.28	5467	4.11	5350	3.95	5042	3.64	4734	3.34	4426	3.04	4119	2.74	3700	2.58	3281	2.48	2862	2.29	2443	2.08	2024	1.84	—
		2	6083	4.85	5954	4.66	5826	4.48	5698	4.30	5390	3.96	5083	3.62	4775	3.28	4468	2.94	4012	2.78	3557	2.64	3101	2.44	2646	2.21	2191	1.95	—
		7	6561	5.35	6418	5.14	6276	4.94	6133	4.74	5826	4.36	5519	3.97	5211	3.59	4904	3.21	4403	3.03	3902	2.83	3401	2.61	2900	2.36	2399	2.08	—
		12	7039	5.66	6882	5.44	6725	5.22	6568	5.01	6261	4.61	5954	4.21	5647	3.82	5340	3.42	4794	3.22	4247	3.01	3700	2.77	3154	2.50	2607	2.19	—
		15	7326	5.84	7161	5.61	6995	5.38	6829	5.17	6523	4.76	6216	4.36	5909	3.95	5602	3.54	5028	3.34	4454	3.11	3880	2.86	3306	2.58	2732	2.26	—
		20	7804	6.14	7624	5.89	7445	5.65	7265	5.42	6958	5.00	6651	4.58	6345	4.16	6038	3.74	5419	3.52	4799	3.28	4180	3.01	3560	2.71	2940	2.37	—
		25	—	—	8088	6.16	7894	5.92	7700	5.67	7394	5.24	7087	4.81	6781	4.37	6475	3.94	5809	3.70	5144	3.44	4479	3.15	3814	2.83	—	—	—
30	—	—	—	—	—	8344	6.17	8135	5.92	7829	5.47	7523	5.02	7217	4.57	6911	4.12	6200	3.87	5489	3.59	4779	3.29	—	—	—	—	—	
35	—	—	—	—	—	—	—	8570	6.16	8264	5.69	7959	5.23	7653	4.76	7347	4.30	6324	3.29	5544	2.84	—	—	—	—	—	—	—	
Min.		-25	1818	2.29	1782	2.21	1747	2.13	1711	2.06	1545	1.95	1379	1.84	1213	1.73	1047	1.63	946	1.55	844	1.53	—	—	—	—	—	—	
		-20	2063	2.96	2021	2.86	1980	2.76	1939	2.66	1775	2.48	1611	2.30	1447	2.11	1283	1.93	1154	1.84	1025	1.82	895	1.78	—	—	—	—	—
		-15	2307	3.63	2280	3.50	2213	3.38	2166	3.26	2004	3.00	1842	2.75	1680	2.49	1518	2.24	1362	2.14	1205	2.10	1048	2.08	—	—	—	—	—
		-10	2552	4.30	2499	4.15	2447	4.00	2394	3.86	2234	3.53	2074	3.20	1914	2.87	1754	2.55	1570	2.43	1386	2.40	1201	2.34	1017	2.16	—	—	—
		-7	2699	4.70	2643	4.53	2587	4.37	2530	4.22	2372	3.84	2213	3.47	2054	3.10	1895	2.73	1694	2.60	1494	2.58	1293	2.47	1092	2.27	892	2.03	—
		-2	2944	5.37	2882	5.18	2820	4.99	2758	4.81	2601	4.37	2444	3.92	2287	3.48	2131	3.03	1903	2.89	1674	2.86	1446	2.66	1218	2.44	990	2.17	—
		2	3140	5.90	3073	5.69	3006	5.49	2940	5.29	2785	4.79	2629	4.29	2474	3.78	2319	3.28	2069	3.12	1819	3.02	1569	2.81	1318	2.57	1068	2.28	—
		7	3385	6.57	3312	6.34	3240	6.11	3167	5.89	3014	5.32	2861	4.74	2708	4.16	2555	3.59	2277	3.41	1999	3.22	1721	2.99	1444	2.72	1166	2.40	—
		12	3630	6.90	3551	6.66	3473	6.43	3395	6.20	3243	5.60	3092	5.00	2941	4.40	2790	3.80	2485	3.61	2180	3.40	1874	3.15	1569	2.86	1264	2.52	—
		15	3776	7.09	3695	6.85	3613	6.61	3531	6.38	3381	5.77	3231	5.15	3081	4.54	2931	3.92	2610	3.73	2288	3.50	1966	3.25	1645	2.95	1323	2.59	—
		20	4021	7.41	3934	7.16	3846	6.91	3759	6.67	3611	6.03	3463	5.40	3315	4.76	3167	4.12	2818	3.91	2468	3.67	2119	3.40	1770	3.08	1421	2.69	—
		25	—	—	—	—	—	4173	7.45	4079	7.20	3986	6.96	3840	6.29	3694	5.63	3548	4.97	3403	4.30	3026	4.08	2649	3.83	2272	3.54	1895	3.20
30	—	—	—	—	—	—	—	4313	7.48	4213	7.23	4070	6.54	3926	5.85	3782	5.16	3638	4.48	3234	4.24	2829	3.98	2425	3.67	—	—	—	
35	—	—	—	—	—	—	—	—	—	4441	7.49	4299	6.78	4157	6.07	4015	5.35	3874	4.64	3298	3.61	2858	3.14	—	—	—	—	—	



Water Out(°C) Ambient Temperature(°C)		AW142/AW14N																			
		20	25	30	35	40	45	50	55	60	65	70	75	80							
-25	Capacity	8628	8571	8515	8458	1.76	7685	6912	1.58	6139	1.48	5366	1.39	4827	1.29	4289	1.17	—	—	—	—
	COP	1.99	1.92	1.84	1.84	2.27	10306	2.18	8482	1.92	7570	1.79	6658	1.66	5953	1.51	5248	1.39	4543	1.20	—
-20	Capacity	10512	10443	10374	10306	2.18	9394	8482	1.92	7570	1.79	6658	1.66	5953	1.51	5248	1.39	4543	1.20	—	—
	COP	2.43	2.35	2.27	2.27	2.43	11102	2.69	10051	2.27	9001	2.10	7950	1.93	7078	1.74	6206	1.59	5334	1.36	—
-15	Capacity	12396	12315	12234	12153	2.60	11102	10051	2.27	9001	2.10	7950	1.93	7078	1.74	6206	1.59	5334	1.36	—	—
	COP	2.87	2.78	2.69	2.69	3.02	12810	2.81	11621	2.61	10431	2.41	9242	2.20	8203	1.96	7165	1.78	6126	1.51	5088
-10	Capacity	14280	14187	14093	14000	3.02	12810	11621	2.61	10431	2.41	9242	2.20	8203	1.96	7165	1.78	6126	1.51	5088	1.25
	COP	3.31	3.21	3.11	3.11	3.27	13260	3.04	12179	2.82	11098	2.59	10017	2.37	8879	2.10	7740	1.88	6602	1.60	5463
-7	Capacity	14673	14562	14451	14341	3.27	13260	12179	2.82	11098	2.59	10017	2.37	8879	2.10	7740	1.88	6602	1.60	5463	1.32
	COP	3.58	3.47	3.37	3.37	3.43	14009	3.43	13109	3.16	12209	2.90	11309	2.64	10004	2.32	8699	2.05	7394	1.73	6088
-2	Capacity	15328	15188	15048	14909	3.69	14009	13109	3.16	12209	2.90	11309	2.64	10004	2.32	8699	2.05	7394	1.73	6088	1.42
	COP	4.02	3.90	3.79	3.79	4.02	14808	3.73	13853	3.44	13098	3.15	12343	2.86	10904	2.50	9466	2.18	8027	1.84	6589
2	Capacity	15852	15689	15526	15363	4.02	14808	13853	3.44	13098	3.15	12343	2.86	10904	2.50	9466	2.18	8027	1.84	6589	1.49
	COP	4.37	4.25	4.13	4.13	4.44	15357	4.11	14783	3.79	14209	3.46	13635	3.13	12030	2.73	10424	2.34	8819	1.96	7214
7	Capacity	16506	16315	16123	15931	4.44	15357	14783	3.79	14209	3.46	13635	3.13	12030	2.73	10424	2.34	8819	1.96	7214	1.58
	COP	4.81	4.68	4.56	4.56	4.62	15499	4.16	14499	3.71	13500	3.26	12500	2.80	11213	2.48	9927	2.17	8640	1.86	7354
12	Capacity	17161	16940	16720	16499	4.62	15499	14499	3.71	13500	3.26	12500	2.80	11213	2.48	9927	2.17	8640	1.86	7354	1.56
	COP	5.01	4.87	4.74	4.74	4.72	15903	4.27	14966	3.81	14030	3.35	13093	2.89	11743	2.56	10393	2.23	9043	1.91	7692
15	Capacity	17554	17316	17078	16840	4.72	15903	14966	3.81	14030	3.35	13093	2.89	11743	2.56	10393	2.23	9043	1.91	7692	1.60
	COP	5.13	4.99	4.85	4.85	4.90	16576	4.44	15745	3.97	14913	3.51	14082	3.04	12626	2.68	11169	2.34	9713	2.00	8257
20	Capacity	18209	17942	17675	17408	4.90	16576	15745	3.97	14913	3.51	14082	3.04	12626	2.68	11169	2.34	9713	2.00	8257	1.67
	COP	5.33	5.18	5.04	5.04	5.08	17249	4.61	16523	4.13	15797	3.66	15071	3.19	13508	2.80	11946	2.43	10384	2.08	8822
25	Capacity	—	18568	18272	17975	5.08	17249	16523	4.13	15797	3.66	15071	3.19	13508	2.80	11946	2.43	10384	2.08	8822	1.73
	COP	—	5.38	5.23	5.23	5.27	17922	4.78	17301	4.29	16680	3.81	16059	3.32	14391	2.92	12723	2.53	11054	2.15	—
30	Capacity	—	—	18868	18543	5.27	17922	17301	4.29	16680	3.81	16059	3.32	14391	2.92	12723	2.53	11054	2.15	—	—
	COP	—	—	—	—	—	18596	4.95	18080	4.45	17564	3.95	17048	3.45	14679	2.48	12850	2.00	—	—	—
35	Capacity	—	—	—	19111	5.45	18596	18080	4.45	17564	3.95	17048	3.45	14679	2.48	12850	2.00	—	—	—	—
	COP	—	—	—	—	—	19111	5.45	18080	4.45	17564	3.95	17048	3.45	14679	2.48	12850	2.00	—	—	—
-25	Capacity	7980	7853	7727	7600	1.89	7023	6446	1.58	5869	1.47	5292	1.35	4753	1.24	4213	1.23	—	—	—	—
	COP	2.07	1.98	1.89	1.89	2.13	8094	2.13	7587	1.97	7081	1.81	6575	1.64	5859	1.49	5144	1.45	4429	1.24	—
-20	Capacity	9030	8887	8743	8600	2.29	8094	7587	1.97	7081	1.81	6575	1.64	5859	1.49	5144	1.45	4429	1.24	—	—
	COP	2.60	2.50	2.39	2.39	2.57	9164	2.57	8729	2.36	8293	2.14	7857	1.93	6966	1.73	6076	1.65	5185	1.40	—
-15	Capacity	10080	9920	9760	9600	2.79	9164	8729	2.36	8293	2.14	7857	1.93	6966	1.73	6076	1.65	5185	1.40	—	—
	COP	3.13	3.01	2.90	2.90	3.01	10235	3.01	9870	2.75	9505	2.48	9140	2.22	8073	1.97	7007	1.84	5941	1.55	4875
-10	Capacity	11130	10953	10777	10600	3.28	10235	9870	2.75	9505	2.48	9140	2.22	8073	1.97	7007	1.84	5941	1.55	4875	1.26
	COP	3.66	3.53	3.40	3.40	3.57	10877	3.28	10555	2.98	10232	2.69	9909	2.39	8738	2.11	7566	1.94	6395	1.63	5223
-7	Capacity	11760	11573	11387	11200	3.57	10877	10555	2.98	10232	2.69	9909	2.39	8738	2.11	7566	1.94	6395	1.63	5223	1.33
	COP	3.98	3.84	3.71	3.71	3.72	11948	3.72	11696	3.37	11444	3.03	11192	2.68	9845	2.35	8498	2.11	7151	1.76	5804
-2	Capacity	12810	12607	12403	12200	4.06	11948	11696	3.37	11444	3.03	11192	2.68	9845	2.35	8498	2.11	7151	1.76	5804	1.42
	COP	4.51	4.36	4.21	4.21	4.46	12804	4.07	12609	3.68	12413	3.30	12218	2.91	10730	2.55	9243	2.23	7755	1.86	6268
2	Capacity	13650	13433	13217	13000	4.46	12804	12609	3.68	12413	3.30	12218	2.91	10730	2.55	9243	2.23	7755	1.86	6268	1.50
	COP	4.94	4.77	4.61	4.61	4.95	13875	4.51	13750	4.08	13625	3.64	13500	3.20	11837	2.79	10174	2.38	8511	1.98	6848
7	Capacity	14700	14467	14233	14000	4.95	13875	13750	4.08	13625	3.64	13500	3.20	11837	2.79	10174	2.38	8511	1.98	6848	1.59
	COP	5.47	5.29	5.12	5.12	5.09	14406	4.63	14229	4.16	14052	3.70	13875	3.24	12218	2.83	10561	2.42	8904	2.02	7247
12	Capacity	15575	15244	14914	14683	5.09	14406	14229	4.16	14052	3.70	13875	3.24	12218	2.83	10561	2.42	8904	2.02	7247	1.63
	COP	5.70	5.49	5.28	5.28	5.17	14725	4.69	14517	4.22	14308	3.74	14100	3.27	12447	2.85	10793	2.45	9140	2.05	7486
15	Capacity	16100	15711	15322	14933	5.17	14725	14517	4.22	14308	3.74	14100	3.27	12447	2.85	10793	2.45	9140	2.05	7486	1.66
	COP	5.83	5.60	5.38	5.38	5.30	15256	4.80	14996	4.30	14735	3.81	14475	3.31	12828	2.89	11180	2.48	9533	2.09	7885
20	Capacity	16975	16489	16003	15517	5.30	15256	14996	4.30	14735	3.81	14475	3.31	12828	2.89	11180	2.48	9533	2.09	7885	1.70
	COP	6.04	5.79	5.54	5.54	5.42	15788	4.90	15475	4.39	15163	3.87	14850	3.35	13209	2.93	11567	2.52	9926	2.12	8284
25	Capacity	—	17267	16683	16100	5.42	15788	15475	4.39	15163	3.87	14850	3.35	13209	2.93	11567	2.52	9926	2.12	8284	1.74
	COP	—	5.97	5.69	5.69	5.54	16319	5.01	15954	4.47	15590	3.93	15225	3.39	13589	2.96	11954	2.55	10318	2.16	—
30	Capacity	—	—	17364	16683	5.54	16319	15954	4.47	15590	3.93	15225	3.39	13589	2.96	11954	2.55	10318	2.16	—	—
	COP	—	—	—	—	—	17267	5.66	16433	4.55	16017	3.99	15600	3.43	13861	2.52	12074	2.02	—	—	—
35	Capacity	—	—	—	17267	5.66	16850	16433	4.55	16017	3.99	15600	3.43	13861	2.52	12074	2.02	—	—	—	—
	COP	—	—	—	—	—	—	—	—	—	—	—	—	—	—	—	—	—	—	—	—

Max.

Nom.

Water Out(°C) Ambient Temperature(°C)		AW142/AW14N																			
		20	25	30	35	40	45	50	55	60	65	70	75	80							
		Capacity	COP	Capacity	COP	Capacity	COP	Capacity	COP	Capacity	COP	Capacity	COP	Capacity	COP	Capacity	COP				
Mid.	-25	4083	2.08	4024	2.00	3965	1.93	3906	1.85	3572	1.77	3239	1.68	2905	1.59	2571	1.51	2311	1.43	2050	1.41
	-20	4641	2.56	4565	2.47	4490	2.38	4414	2.28	4087	2.16	3761	2.03	3435	1.91	3108	1.78	2787	1.69	2466	1.67
	-15	5199	3.05	5107	2.94	5014	2.82	4922	2.71	4602	2.55	4283	2.38	3964	2.22	3645	2.06	3264	1.94	2882	1.98
	-10	5757	3.54	5648	3.40	5539	3.27	5429	3.14	5117	2.94	4806	2.74	4494	2.53	4182	2.33	3740	2.20	3298	2.15
	-7	6092	3.83	5973	3.68	5853	3.54	5734	3.40	5426	3.17	5119	2.95	4812	2.72	4504	2.49	4026	2.35	3547	2.32
	-2	6650	4.32	6514	4.15	6378	3.99	6242	3.83	5941	3.56	5641	3.30	5341	3.03	5041	2.77	4502	2.60	3963	2.51
	2	7096	4.71	6947	4.52	6797	4.35	6648	4.17	6353	3.88	6059	3.58	5765	3.28	5471	2.99	4883	2.81	4296	2.66
	7	7654	5.20	7488	4.99	7322	4.79	7155	4.60	6869	4.27	6582	3.93	6295	3.60	6008	3.26	5360	3.06	4712	2.84
	12	8212	5.49	8029	5.28	7846	5.07	7663	4.86	7384	4.51	7104	4.16	6824	3.82	6545	3.47	5836	3.25	5128	3.01
	15	8547	5.67	8354	5.44	8161	5.23	7968	5.02	7693	4.66	7417	4.30	7142	3.94	6867	3.59	6122	3.36	5377	3.10
	20	9105	5.96	8895	5.72	8685	5.49	8475	5.26	8208	4.89	7940	4.52	7672	4.15	7404	3.78	6599	3.53	5793	3.26
	25	—	—	9436	5.98	9210	5.74	8983	5.51	8723	5.12	8462	4.73	8201	4.35	7941	3.96	7075	3.69	6209	3.40
	30	—	—	—	—	9734	5.99	9491	5.74	9238	5.34	8984	4.94	8731	4.54	8478	4.13	7551	3.85	6625	3.54
	35	—	—	—	—	—	—	9998	5.97	9753	5.56	9507	5.14	9261	4.72	9015	4.30	7702	3.27	6691	2.80
	-25	2121	2.21	2079	2.14	2038	2.06	1997	1.99	1816	1.89	1636	1.79	1456	1.69	1276	1.59	1149	1.52	1022	1.50
-20	2406	2.86	2358	2.76	2310	2.67	2262	2.57	2088	2.41	1914	2.24	1740	2.08	1565	1.91	1403	1.82	1240	1.78	
-15	2692	3.51	2637	3.39	2582	3.27	2527	3.16	2359	2.92	2191	2.69	2023	2.46	1855	2.23	1656	2.12	1458	2.11	
-10	2978	4.16	2916	4.02	2854	3.88	2793	3.74	2631	3.44	2469	3.15	2307	2.85	2145	2.55	1910	2.42	1676	2.41	
-7	3149	4.55	3083	4.39	3018	4.24	2952	4.09	2794	3.75	2635	3.42	2477	3.08	2319	2.74	2063	2.61	1806	2.58	
-2	3435	5.20	3362	5.02	3290	4.84	3217	4.67	3065	4.27	2913	3.87	2761	3.47	2608	3.06	2316	2.91	2024	2.89	
2	3663	5.73	3585	5.52	3507	5.33	3430	5.14	3282	4.68	3135	4.23	2988	3.78	2840	3.32	2519	3.15	2199	3.05	
7	3949	6.38	3864	6.15	3780	5.93	3695	5.72	3554	5.20	3413	4.68	3271	4.16	3130	3.64	2773	3.45	2416	3.23	
12	4235	6.70	4143	6.47	4052	6.24	3960	6.02	3825	5.48	3690	4.93	3555	4.39	3420	3.85	3027	3.64	2634	3.40	
15	4406	6.89	4310	6.65	4215	6.42	4120	6.19	3988	5.64	3857	5.08	3725	4.52	3594	3.96	3179	3.74	2765	3.49	
20	4692	7.19	4589	6.95	4487	6.71	4385	6.48	4260	5.90	4134	5.31	4009	4.73	3883	4.15	3433	3.91	2983	3.65	
25	—	—	4868	7.23	4759	6.99	4650	6.75	4531	6.14	4412	5.54	4293	4.93	4173	4.32	3687	4.07	3201	3.79	
30	—	—	—	—	5031	7.26	4916	7.01	4802	6.38	4689	5.75	4576	5.12	4463	4.48	3941	4.22	3419	3.92	
35	—	—	—	—	—	—	5181	7.27	5074	6.61	4967	5.95	4860	5.30	4753	4.64	4020	3.59	3453	3.10	

Water Out(°C) Ambient Temperature(°C)		AW162/AW16N																											
		20	25	30	35	40	45	50	55	60	65	70	75	80															
		Capacity	COP	Capacity	COP	Capacity	COP	Capacity	COP	Capacity	COP	Capacity	COP	Capacity	COP														
Mid.	-25	4416	2.01	4353	1.96	4289	1.91	4226	1.86	3990	1.80	3753	1.74	3516	1.68	3280	1.62	2945	1.58	2611	1.55	—	—	—	—				
	-20	4921	2.40	4842	2.33	4763	2.27	4684	2.20	4435	2.10	4186	2.00	3938	1.89	3689	1.79	3321	1.73	2953	1.72	2585	1.71	—	—	—	—		
	-15	5426	2.80	5332	2.71	5237	2.62	5142	2.54	4881	2.40	4620	2.25	4359	2.11	4098	1.96	3696	1.89	3295	1.85	2894	1.80	—	—	—	—		
	-10	5931	3.20	5821	3.09	5710	2.98	5600	2.88	5327	2.69	5053	2.51	4780	2.32	4507	2.13	4072	2.05	3638	1.99	3203	1.96	2768	1.80	—	—	—	—
	-7	6235	3.43	6115	3.31	5995	3.19	5875	3.08	5594	2.87	5313	2.66	5033	2.45	4752	2.24	4297	2.15	3843	2.09	3388	2.02	2934	1.86	2479	1.68	—	—
	-2	6740	3.83	6604	3.69	6468	3.55	6333	3.42	6040	3.17	5747	2.91	5454	2.66	5161	2.41	4673	2.31	4185	2.28	3697	2.13	3209	1.96	2721	1.77	—	—
	2	7144	4.15	6996	3.99	6847	3.84	6699	3.69	6396	3.40	6094	3.12	5791	2.83	5488	2.54	4974	2.43	4459	2.36	3944	2.21	3429	2.04	2915	1.85	—	—
	7	7649	4.54	7485	4.37	7321	4.19	7157	4.03	6842	3.70	6527	3.37	6212	3.04	5897	2.72	5349	2.59	4801	2.45	4253	2.30	3705	2.13	3157	1.93	—	—
	12	8154	4.77	7975	4.59	7795	4.40	7615	4.23	7288	3.87	6961	3.52	6634	3.17	6306	2.81	5725	2.69	5143	2.54	4562	2.39	3980	2.21	3399	2.01	—	—
	15	8458	4.91	8268	4.71	8079	4.53	7890	4.35	7555	3.98	7221	3.61	6886	3.24	6552	2.87	5950	2.74	5349	2.59	4747	2.43	4146	2.26	3544	2.05	—	—
20	8963	5.13	8758	4.93	8553	4.73	8348	4.54	8001	4.14	7654	3.75	7308	3.35	6961	2.95	6326	2.82	5691	2.68	5056	2.51	4421	2.33	3786	2.12	—	—	
25	—	—	9247	5.13	9027	4.92	8806	4.72	8447	4.30	8088	3.88	7729	3.46	7370	3.04	6701	2.90	6033	2.75	5365	2.59	4697	2.40	—	—	—	—	
30	—	—	—	—	9500	5.11	9264	4.91	8892	4.46	8521	4.01	8150	3.56	7779	3.11	7077	2.98	6375	2.82	5674	2.65	—	—	—	—	—	—	
35	—	—	—	—	—	—	9722	5.08	9338	4.61	8955	4.14	8571	3.66	8188	3.19	7219	2.53	6439	2.23	—	—	—	—	—	—	—	—	
-25	2294	2.13	2249	2.08	2204	2.04	2160	2.00	2025	1.93	1890	1.86	1756	1.79	1621	1.72	1460	1.68	1298	1.67	—	—	—	—	—	—	—	—	
-20	2552	2.67	2501	2.60	2450	2.53	2400	2.47	2261	2.33	2122	2.19	1984	2.06	1845	1.92	1662	1.87	1478	1.85	1295	1.82	—	—	—	—	—	—	
-15	2810	3.21	2753	3.11	2696	3.02	2639	2.94	2497	2.73	2354	2.53	2212	2.33	2069	2.12	1864	2.06	1658	2.02	1452	1.98	—	—	—	—	—	—	
-10	3069	3.74	3006	3.63	2942	3.52	2879	3.41	2733	3.14	2586	2.86	2440	2.59	2294	2.32	2066	2.25	1838	2.22	1610	2.18	1382	2.13	—	—	—	—	
-7	3224	4.07	3157	3.94	3090	3.81	3023	3.69	2874	3.38	2726	3.07	2577	2.75	2428	2.44	2187	2.36	1946	2.33	1704	2.28	1463	2.19	1221	2.00	—	—	
-2	3482	4.61	3409	4.45	3336	4.30	3263	4.16	3110	3.78	2958	3.40	2805	3.02	2653	2.64	2389	2.55	2125	2.59	1862	2.45	1598	2.29	1335	2.09	—	—	
2	3689	5.04	3611	4.87	3533	4.70	3455	4.53	3299	4.10	3143	3.67	2988	3.24	2832	2.80	2551	2.70	2269	2.67	1988	2.53	1706	2.36	1425	2.16	—	—	
7	3947	5.58	3863	5.38	3779	5.19	3694	5.00	3535	4.50	3375	4.00	3216	3.50	3056	3.00	2753	2.89	2449	2.77	2145	2.62	1842	2.44	1538	2.24	—	—	
12	4206	5.82	4115	5.62	4025	5.42	3934	5.23	3771	4.70	3607	4.16	3444	3.63	3281	3.10	2955	2.98	2629	2.85	2303	2.70	1977	2.52	1651	2.31	—	—	
15	4361	5.96	4266	5.76	4172	5.56	4078	5.37	3912	4.81	3747	4.26	3581	3.70	3415	3.15	3076	3.03	2737	2.90	2397	2.75	2058	2.56	1719	2.35	—	—	
20	4619	6.19	4519	5.98	4418	5.78	4318	5.58	4148	4.99	3979	4.40	3809	3.81	3640	3.23	3278	3.11	2916	2.97	2555	2.82	2193	2.63	1832	2.41	—	—	
25	—	—	—	—	4771	6.20	4664	5.99	4558	5.79	4384	5.17	4211	4.54	4037	3.92	3684	3.30	3480	3.18	3096	3.04	2713	2.88	2329	2.70	—	—	
30	—	—	—	—	—	—	4910	6.20	4797	5.99	4620	5.33	4443	4.68	4265	4.02	4088	3.37	3682	3.25	3276	3.11	2870	2.95	—	—	—	—	
35	—	—	—	—	—	—	—	5037	6.18	4856	5.50	4675	4.81	4494	4.12	4312	3.43	3756	2.76	3309	2.45	—	—	—	—	—	—	—	—

11. Operation Limits Delivery-Leaving

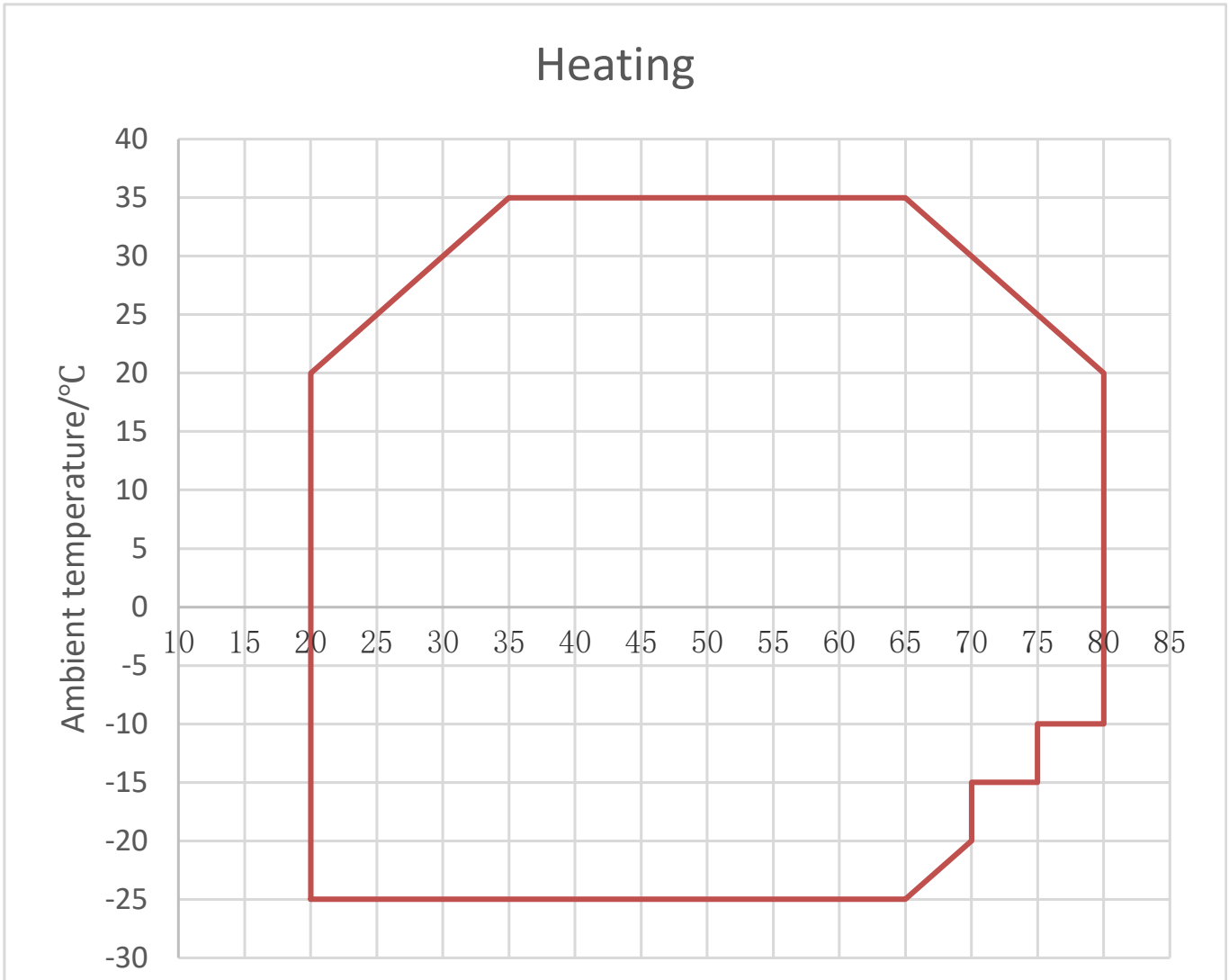

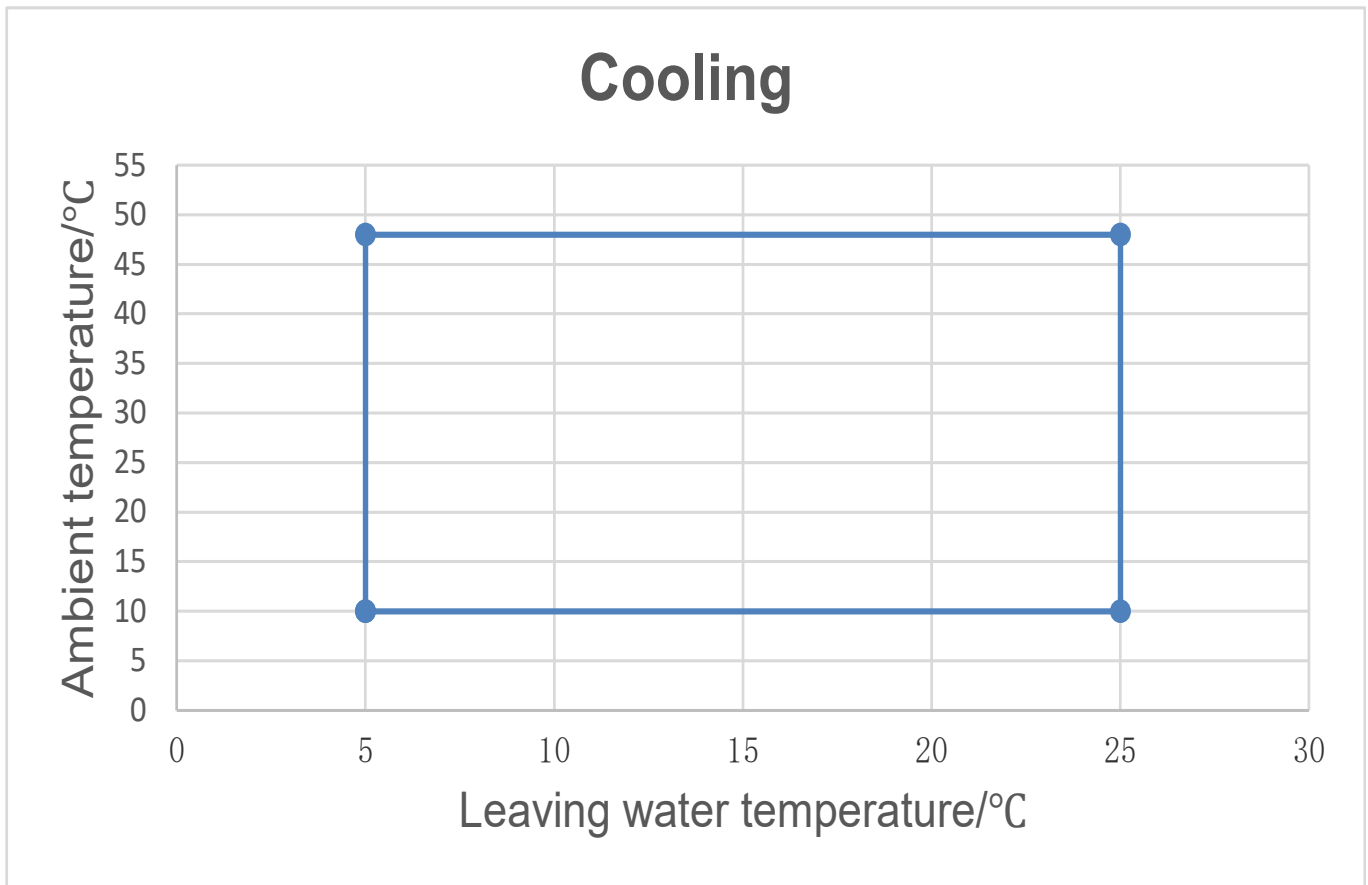

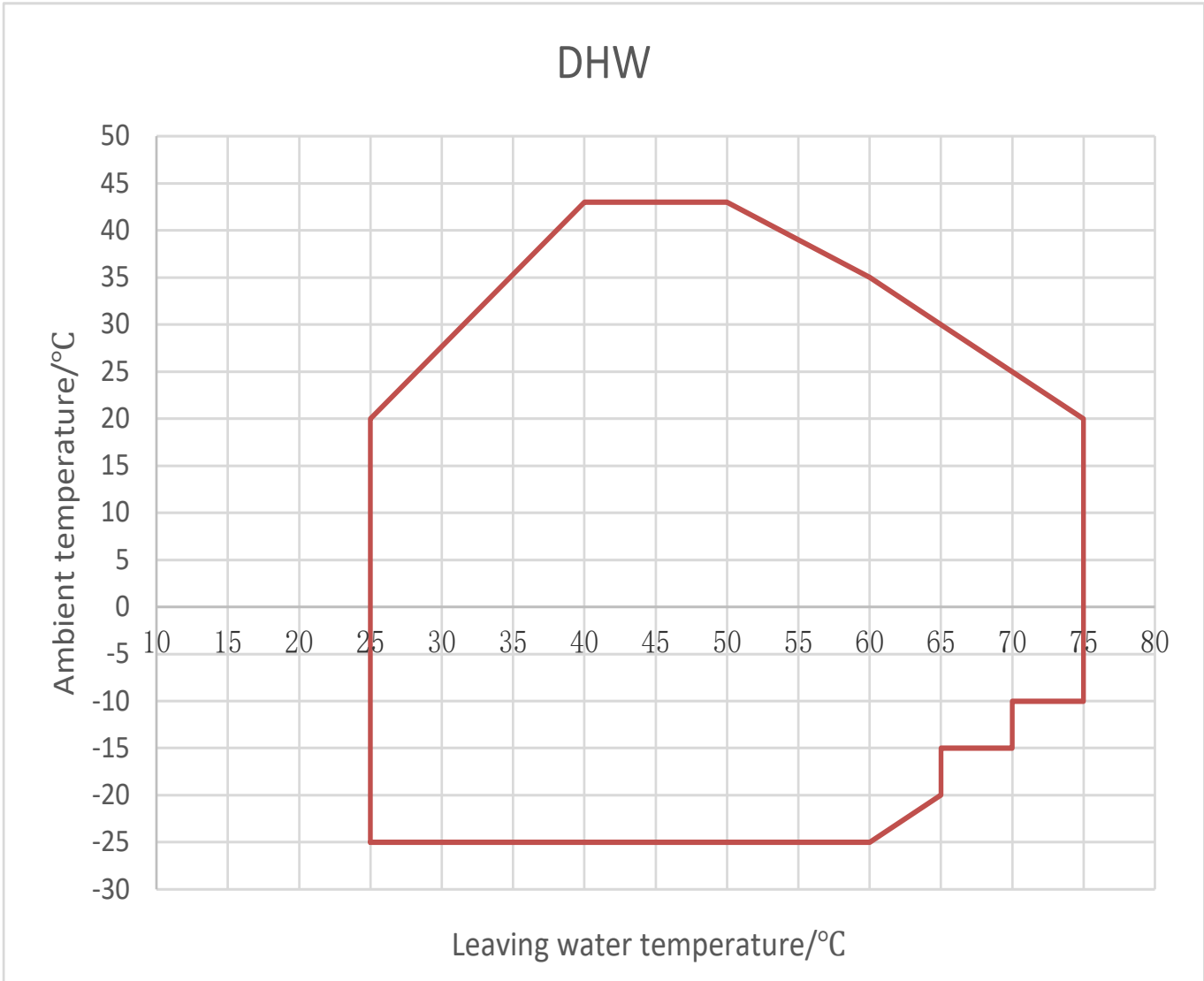

12. Water Pressure Drop

AW042MUGHA Water Pressure Drop

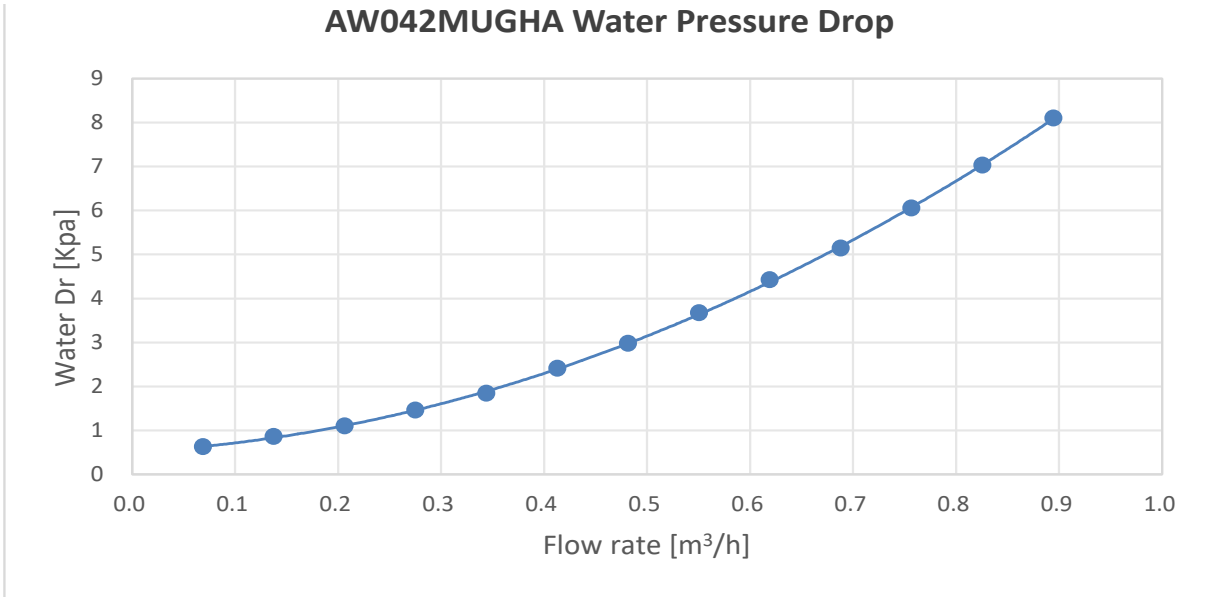

AW042MUGHA Water Pressure External Residual Pressure

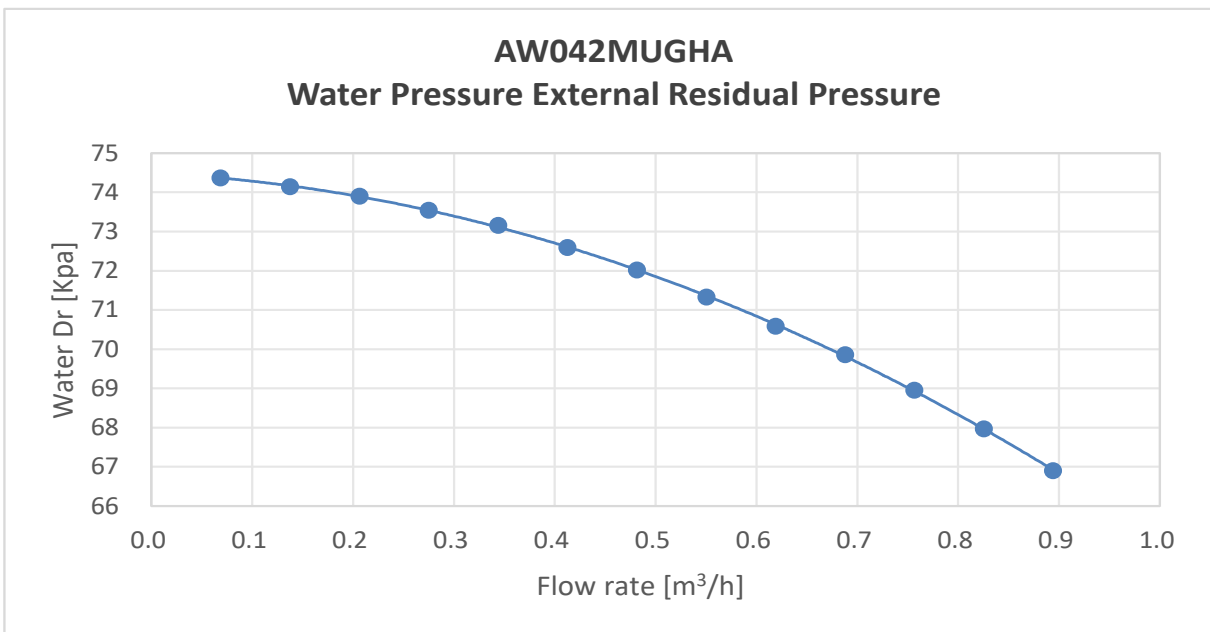

Water Flow (m³/h)			Water Pressure Drop (kPa)	Pump Head	External Residual Pressure
0.688	10%	0.1	1	75	74
0.688	20%	0.1	1	75	74
0.688	30%	0.2	1	75	74
0.688	40%	0.3	1	75	74
0.688	50%	0.3	2	75	73
0.688	60%	0.4	2	75	73
0.688	70%	0.5	3	75	72
0.688	80%	0.6	4	75	71
0.688	90%	0.6	4	75	71
0.688	100%	0.7	5	75	70
0.688	110%	0.8	6	75	69
0.688	120%	0.8	7	75	68
0.688	130%	0.9	8	75	67

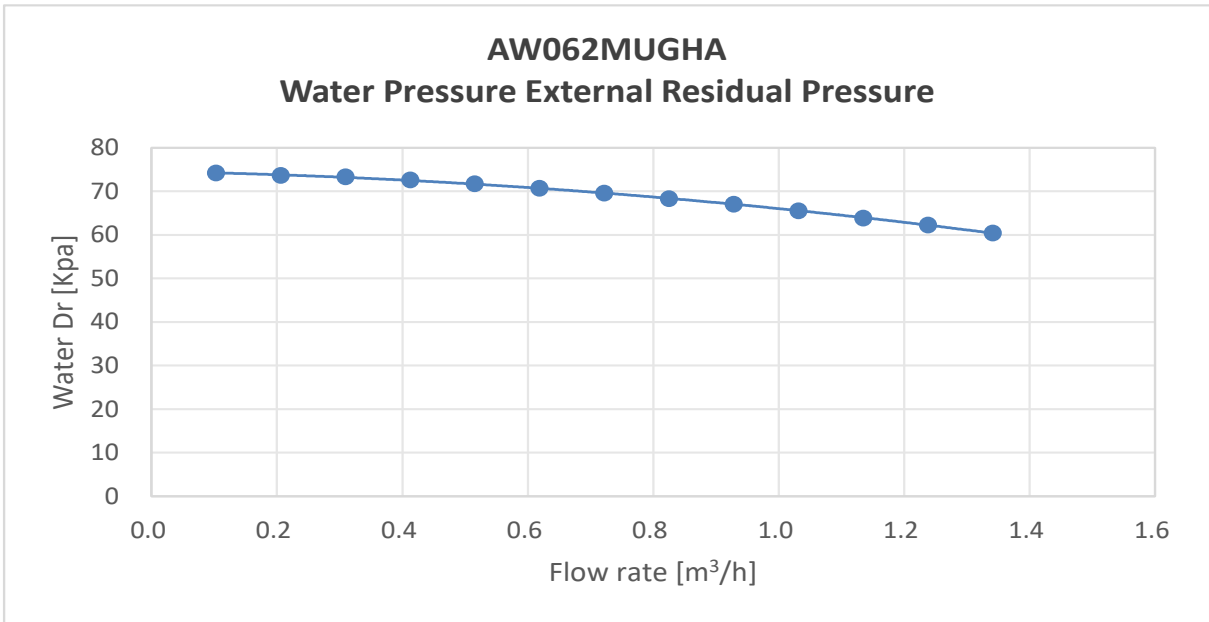
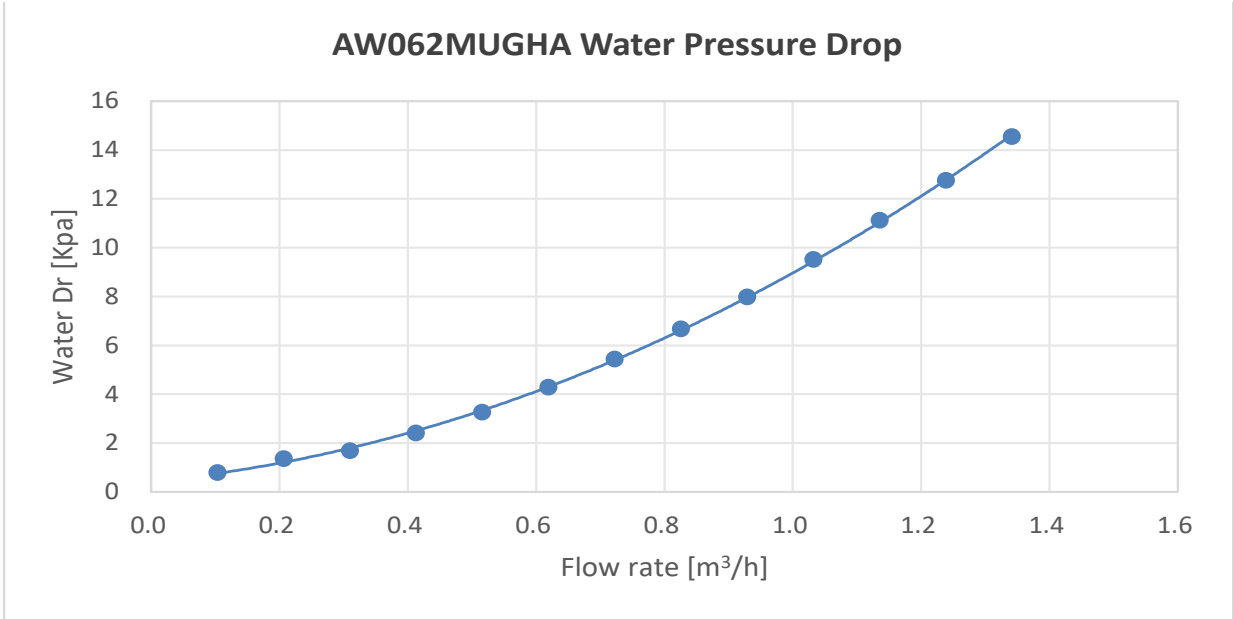

Water Flow (m³/h)			Water Pressure Drop (kPa)	Pump Head	External Residual Pressure
1.032	10%	0.1	1	75	74
1.032	20%	0.2	1	75	74
1.032	30%	0.3	2	75	73
1.032	40%	0.4	2	75	73
1.032	50%	0.5	3	75	72
1.032	60%	0.6	4	75	71
1.032	70%	0.7	5	75	70
1.032	80%	0.8	7	75	68
1.032	90%	0.9	8	75	67
1.032	100%	1.0	10	75	65
1.032	110%	1.1	11	75	64
1.032	120%	1.2	13	75	62
1.032	130%	1.3	15	75	60

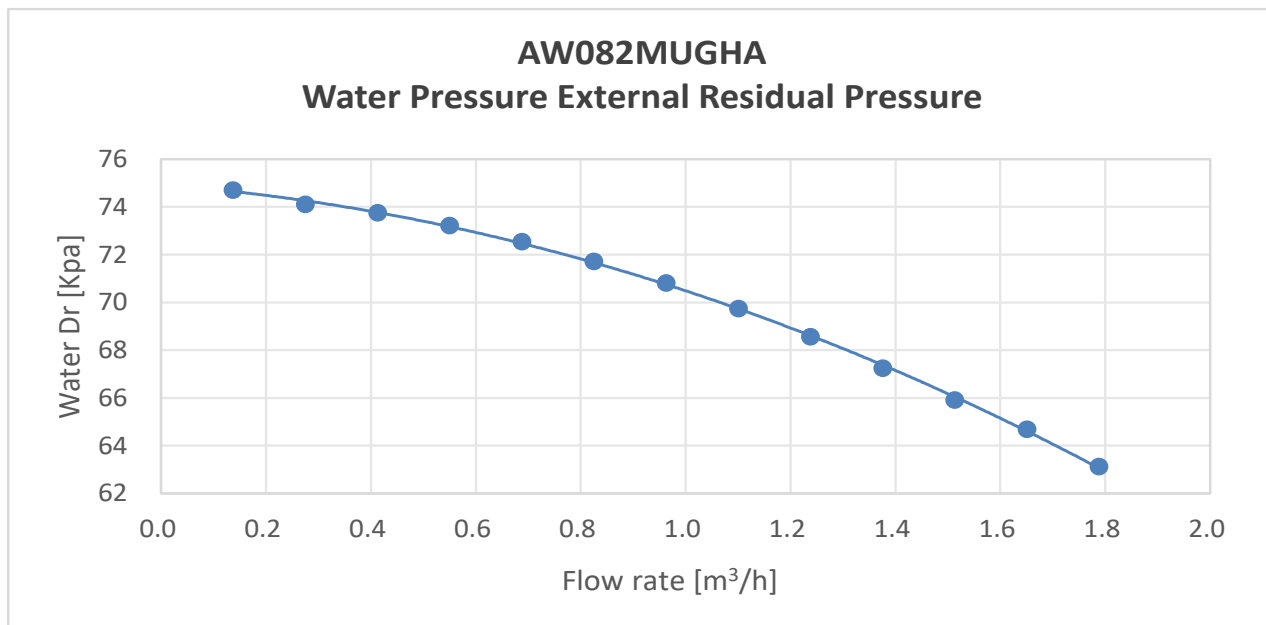
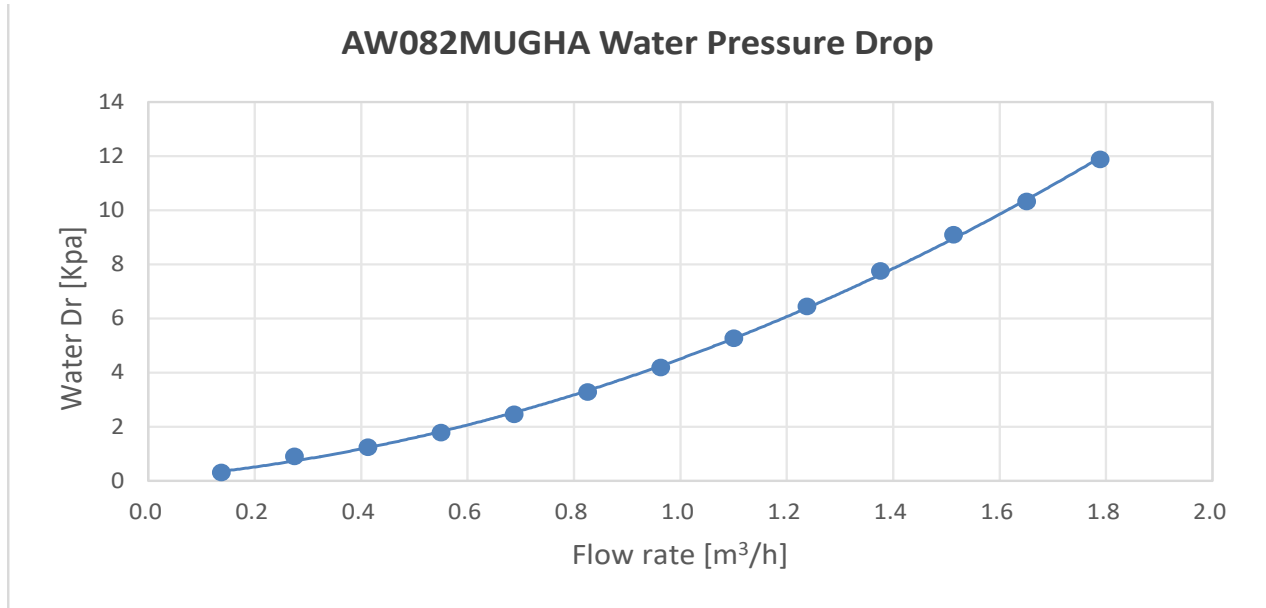

Water Flow (m³/h)			Water Pressure Drop (kPa)	Pump Head	External Residual Pressure
1.376	10%	0.1	0	75	75
1.376	20%	0.3	1	75	74
1.376	30%	0.4	1	75	74
1.376	40%	0.6	2	75	73
1.376	50%	0.7	2	75	73
1.376	60%	0.8	3	75	72
1.376	70%	1.0	4	75	71
1.376	80%	1.1	5	75	70
1.376	90%	1.2	6	75	69
1.376	100%	1.4	8	75	67
1.376	110%	1.5	9	75	66
1.376	120%	1.7	10	75	65
1.376	130%	1.8	12	75	63

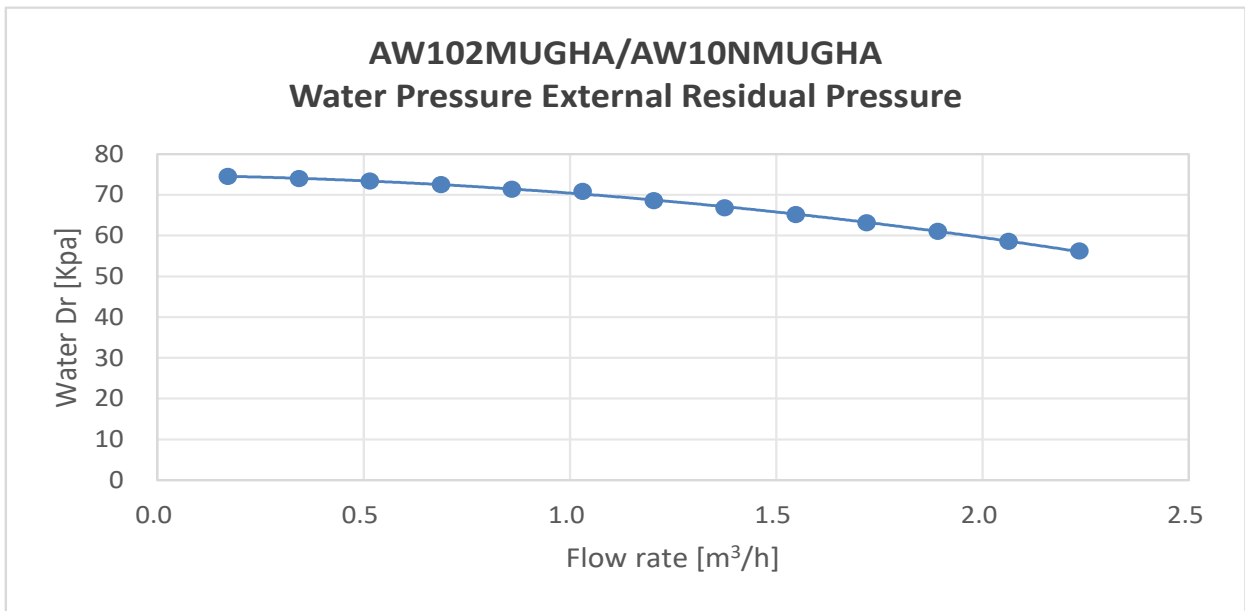
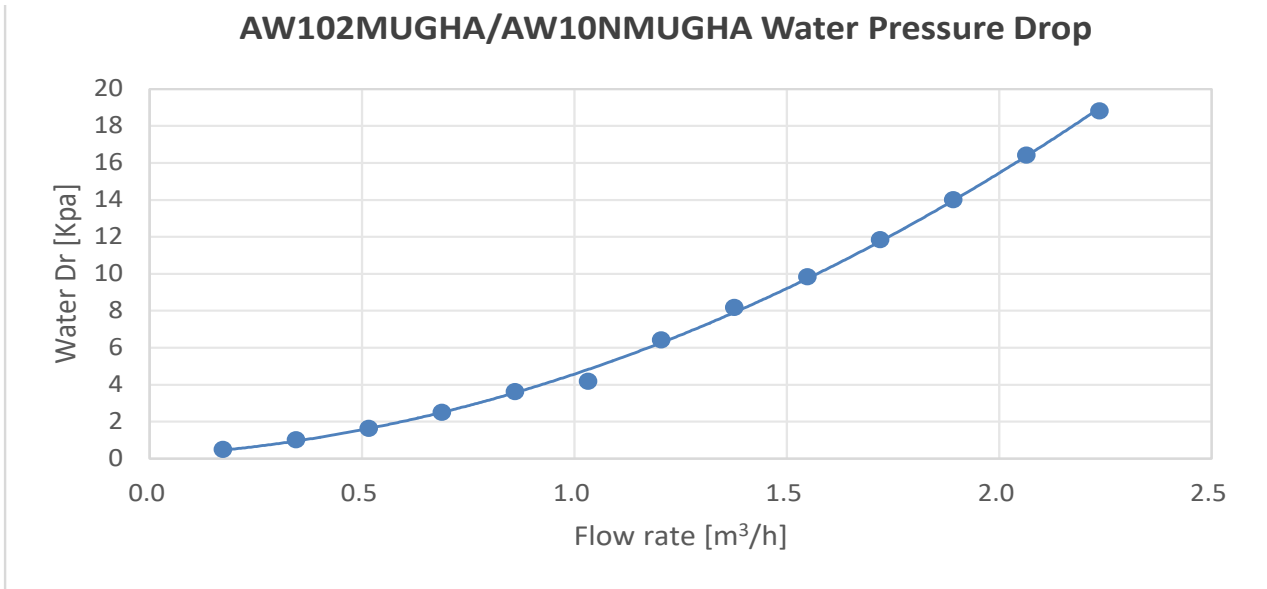

Water Flow (m³/h)			Water Pressure Drop (kPa)	Pump Head	External Residual Pressure
1.032	10%	0.1	1	75	74
1.032	20%	0.2	1	75	74
1.032	30%	0.3	2	75	73
1.032	40%	0.4	2	75	73
1.032	50%	0.5	3	75	72
1.032	60%	0.6	4	75	71
1.032	70%	0.7	5	75	70
1.032	80%	0.8	7	75	68
1.032	90%	0.9	8	75	67
1.032	100%	1.0	10	75	65
1.032	110%	1.1	11	75	64
1.032	120%	1.2	13	75	62
1.032	130%	1.3	15	75	60

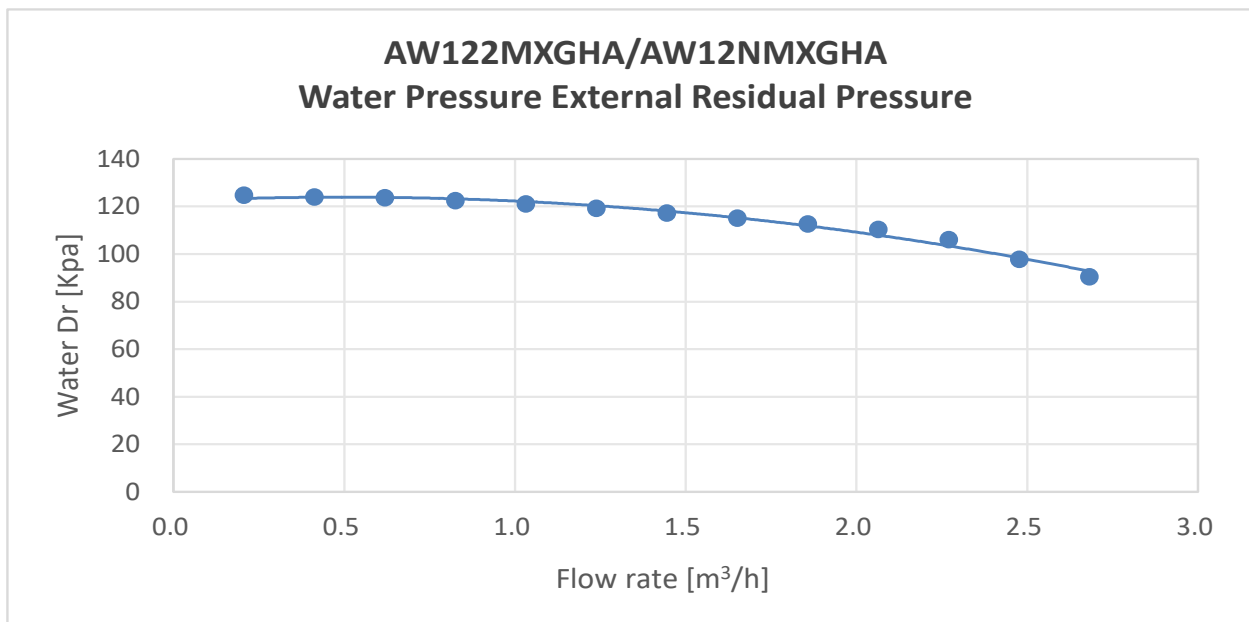
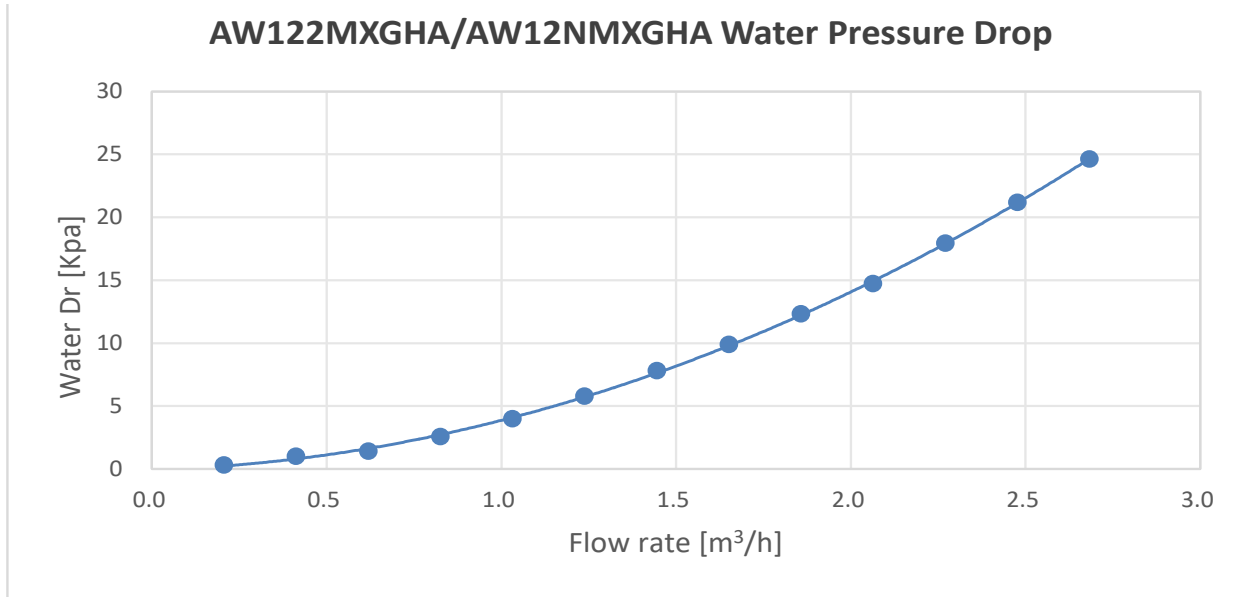

Water Flow (m³/h)			Water Pressure Drop (kPa)	Pump Head	External Residual Pressure
2.064	10%	0.2	0	125	125
2.064	20%	0.4	1	125	124
2.064	30%	0.6	1	125	124
2.064	40%	0.8	3	125	122
2.064	50%	1.0	4	125	121
2.064	60%	1.2	6	125	119
2.064	70%	1.4	8	125	117
2.064	80%	1.65	10	125	115
2.064	90%	1.86	12	125	113
2.064	100%	2.06	15	125	110
2.064	110%	2.27	18	124	106
2.064	120%	2.48	21	119	98
2.064	130%	2.68	25	115	90

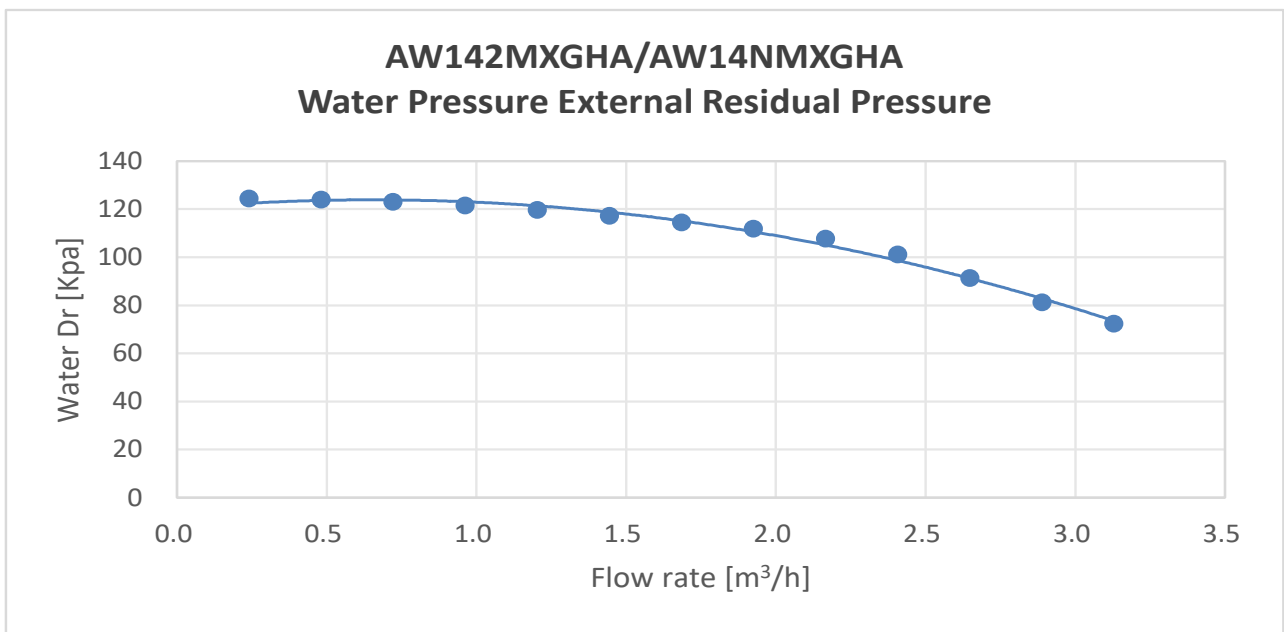
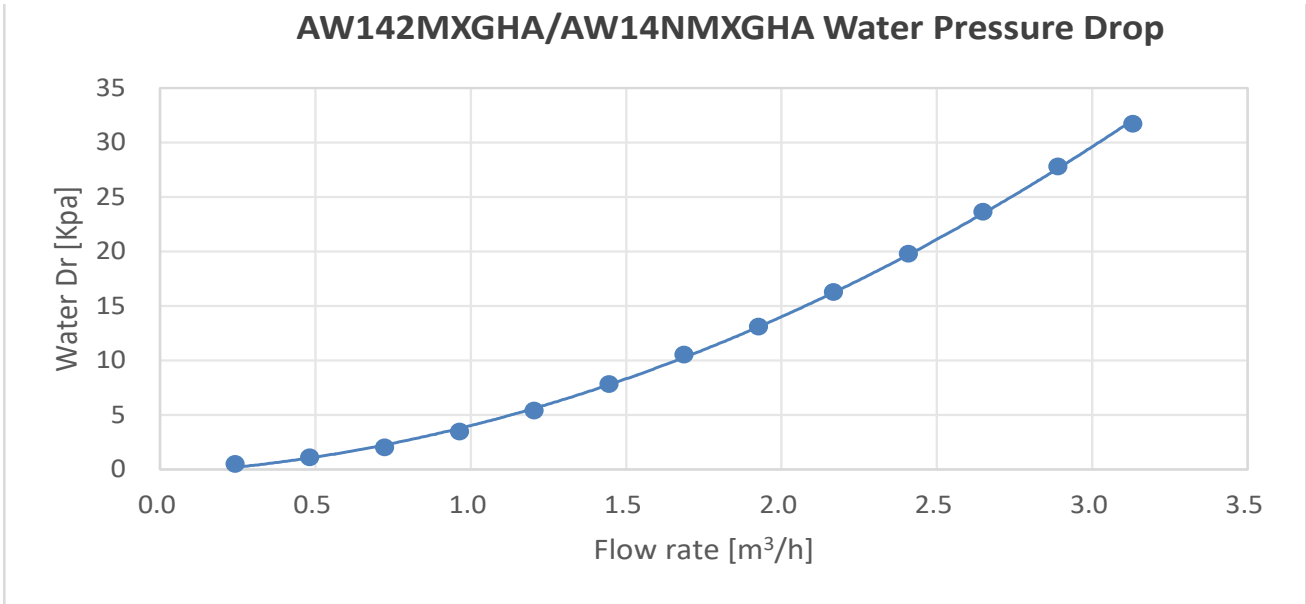

Water Flow (m³/h)			Water Pressure Drop (kPa)	Pump Head	External Residual Pressure
2.408	10%	0.2	1	125	125
2.408	20%	0.5	1	125	124
2.408	30%	0.7	2	125	123
2.408	40%	1.0	3	125	122
2.408	50%	1.2	5	125	120
2.408	60%	1.4	8	125	117
2.408	70%	1.69	11	125	114
2.408	80%	1.93	13	125	112
2.408	90%	2.17	16	124	108
2.408	100%	2.41	20	121	101
2.408	110%	2.65	24	115	91
2.408	120%	2.89	28	109	81
2.408	130%	3.13	32	104	72

AW162MXGHA/AW16NMXGHA Water Pressure Drop

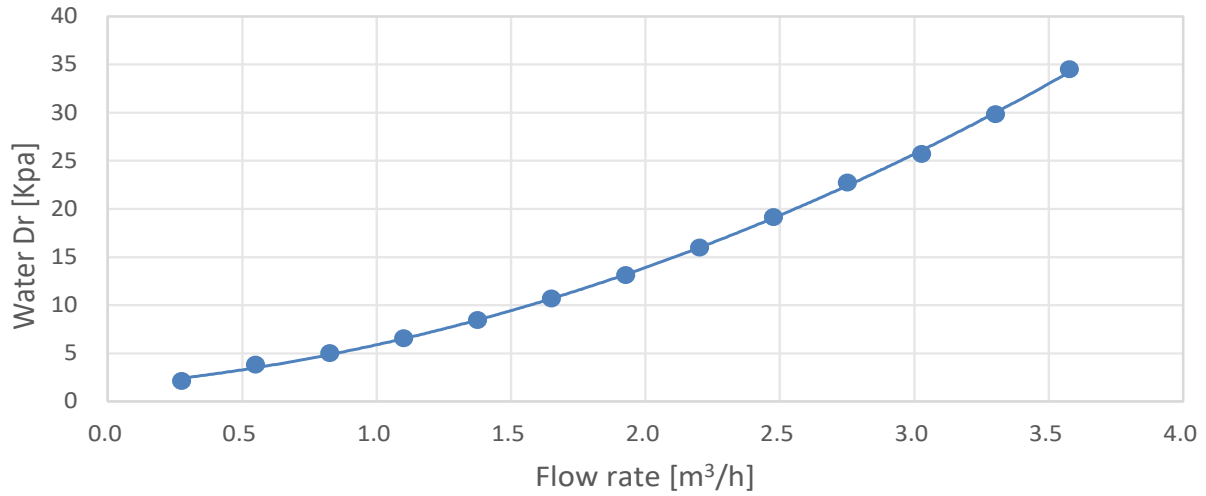

**AW162MXGHA/AW16NMXGHA
Water Pressure External Residual Pressure**

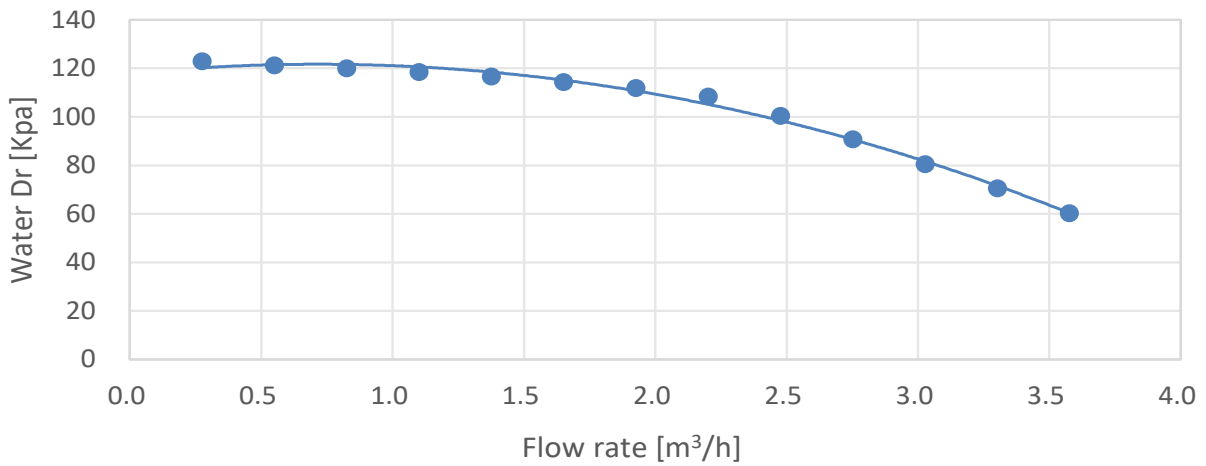

Water Flow (m³/h)			Water Pressure Drop (kPa)	Pump Head	External Residual Pressure
2.752	10%	0.3	2	125	123
2.752	20%	0.6	4	125	121
2.752	30%	0.8	5	125	120
2.752	40%	1.1	7	125	118
2.752	50%	1.4	8	125	117
2.752	60%	1.7	11	125	114
2.752	70%	1.9	13	125	112
2.752	80%	2.2	16	124	108
2.752	90%	2.5	19	120	100
2.752	100%	2.8	23	113	91
2.752	110%	3.0	26	106	80
2.752	120%	3.3	30	100	71
2.752	130%	3.6	35	95	60

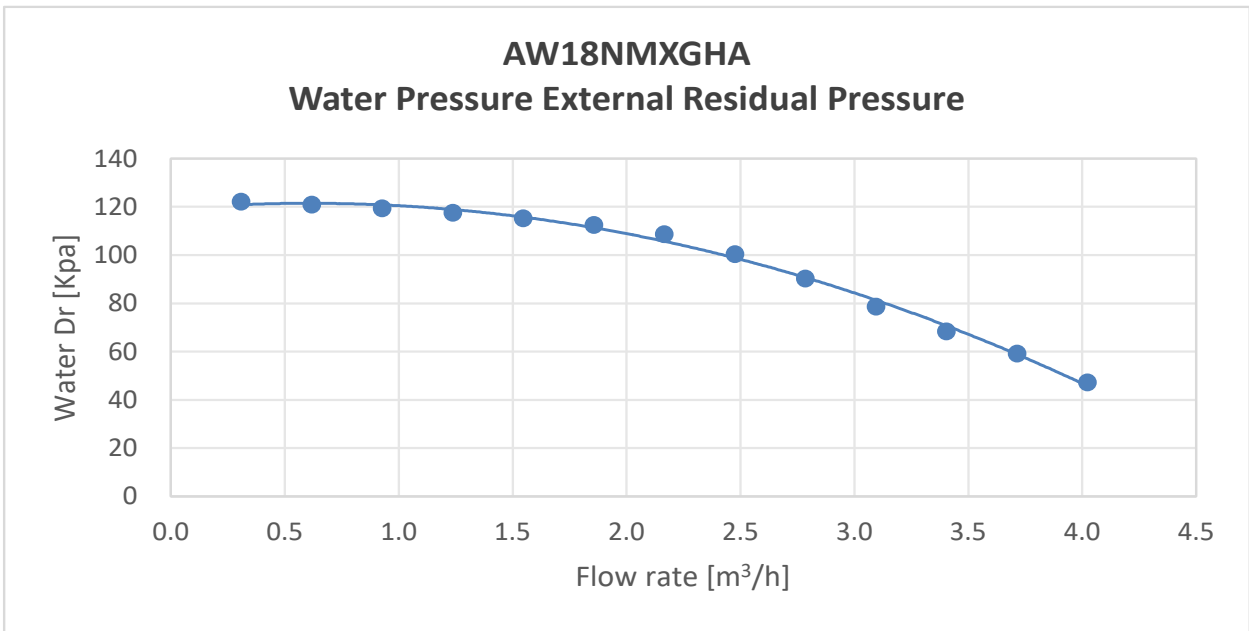
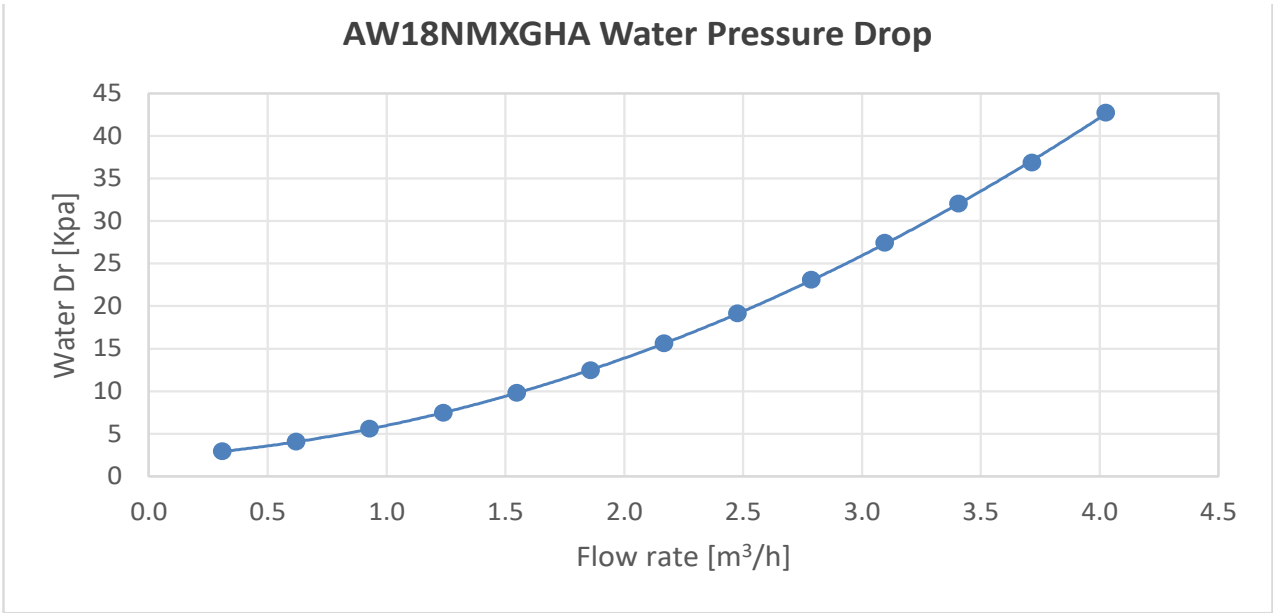

Water Flow (m³/h)			Water Pressure Drop (kPa)	Pump Head	External Residual Pressure
3.096	10%	0.3	3	125	122
3.096	20%	0.6	4	125	121
3.096	30%	0.9	6	125	119
3.096	40%	1.2	7	125	118
3.096	50%	1.5	10	125	115
3.096	60%	1.9	12	125	113
3.096	70%	2.2	16	124	109
3.096	80%	2.5	19	120	100
3.096	90%	2.8	23	113	90
3.096	100%	3.1	27	106	79
3.096	110%	3.4	32	100	68
3.096	120%	3.7	37	96	59
3.096	130%	4.0	43	90	47

13. Water Pump Characteristic Curve

1m head can overcome 10kpa water pressure

Performance Curve

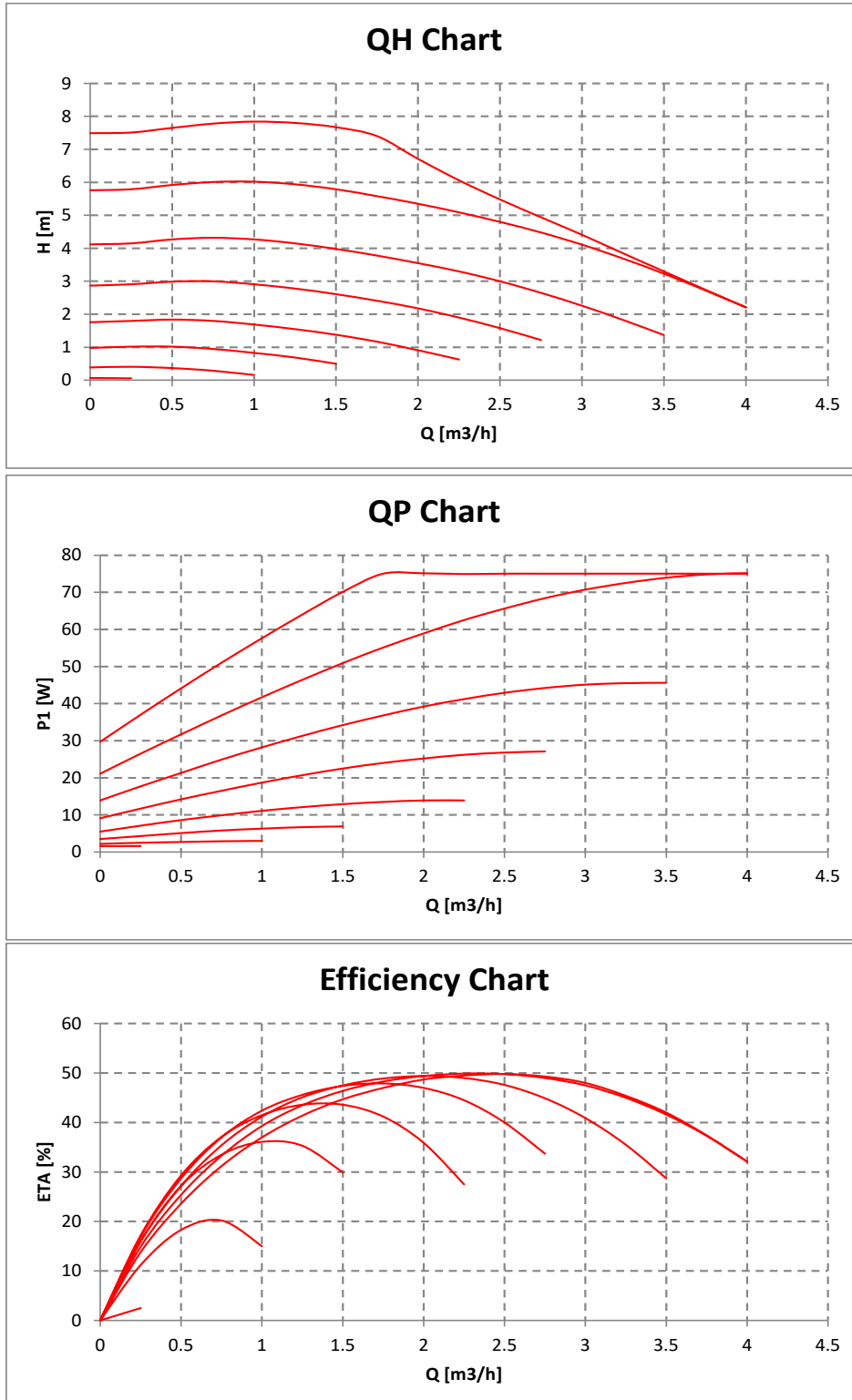

The Performance of PWM was measured under 8 PWM value (heating). 5 % (max.), 20 %, 31 %, 41 %, 52 %, 62 %, 73 %, 88 % (min.).

According to ISO 9906, system 2.0 bar, water temperature 20°C

1m head can overcome 10kpa water pressure

Performance Curve

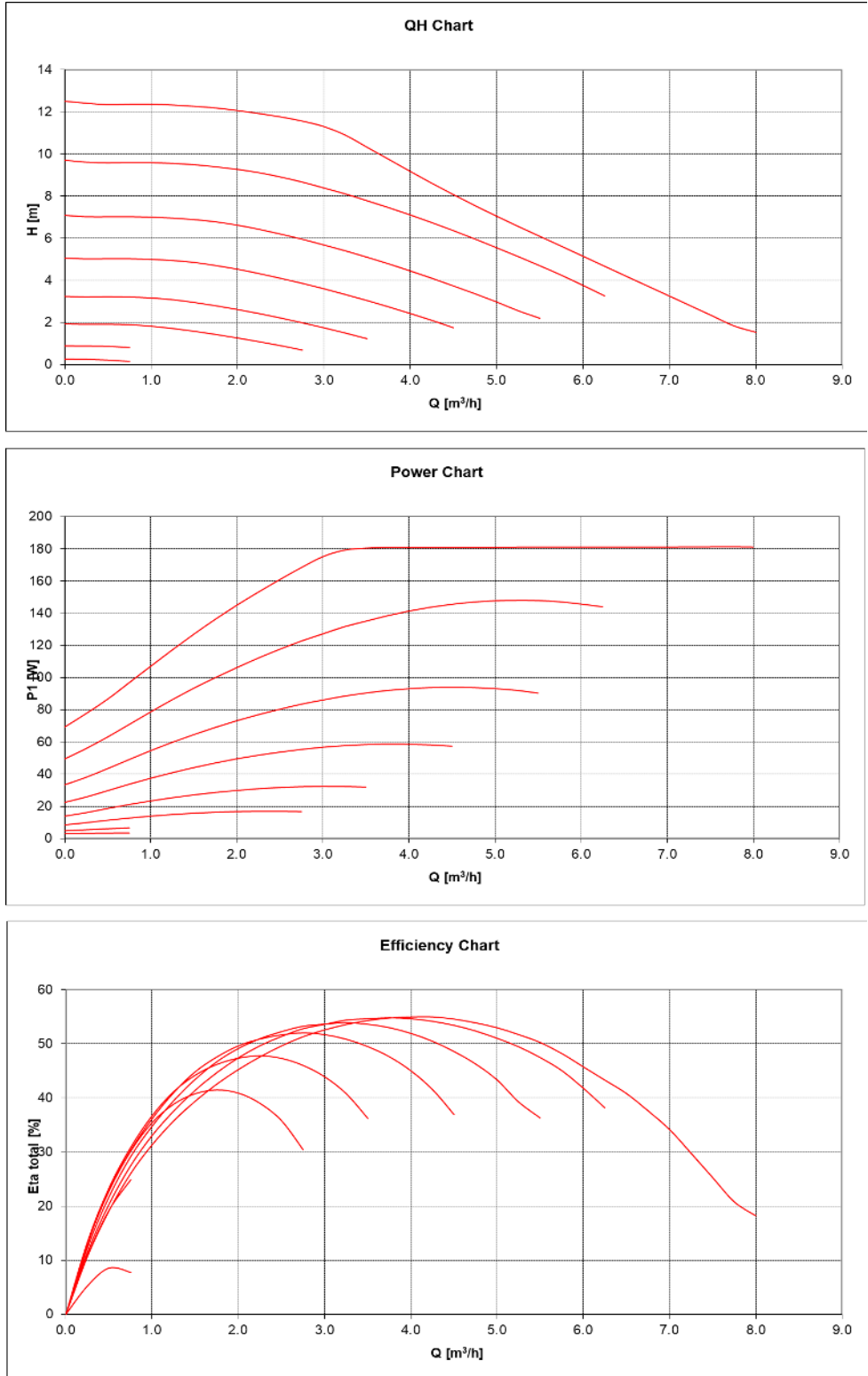

The Performance of PWM was measured under 8 PWM value (heating). 5 % (max.), 20 %, 31 %, 41 %, 52 %, 62 %, 73 %, 88 % (min.).
 According to ISO 9906, system 2.0 bar, water temperature 20°C

14. Sound Level

AW042MUGHA

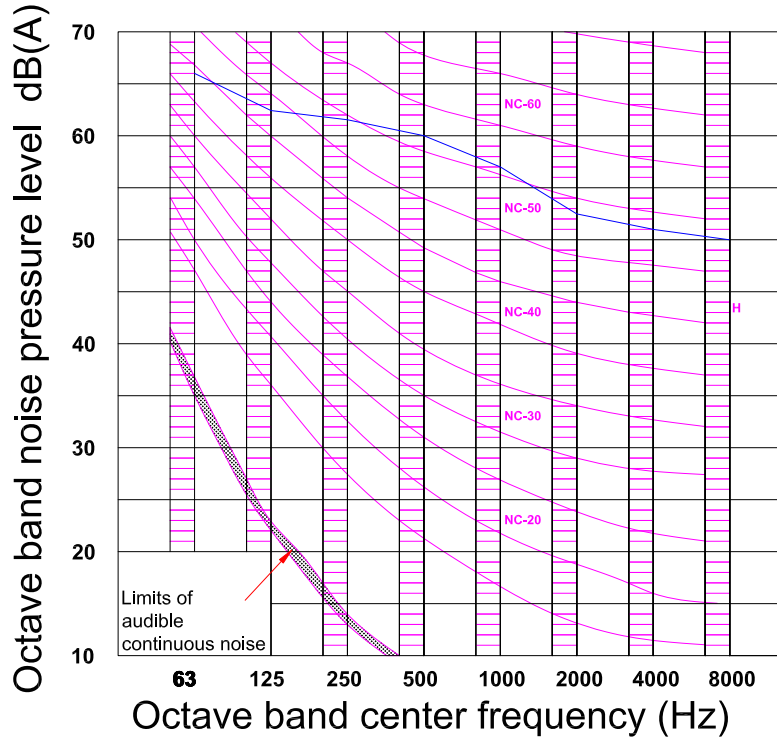

AW062MUGHA

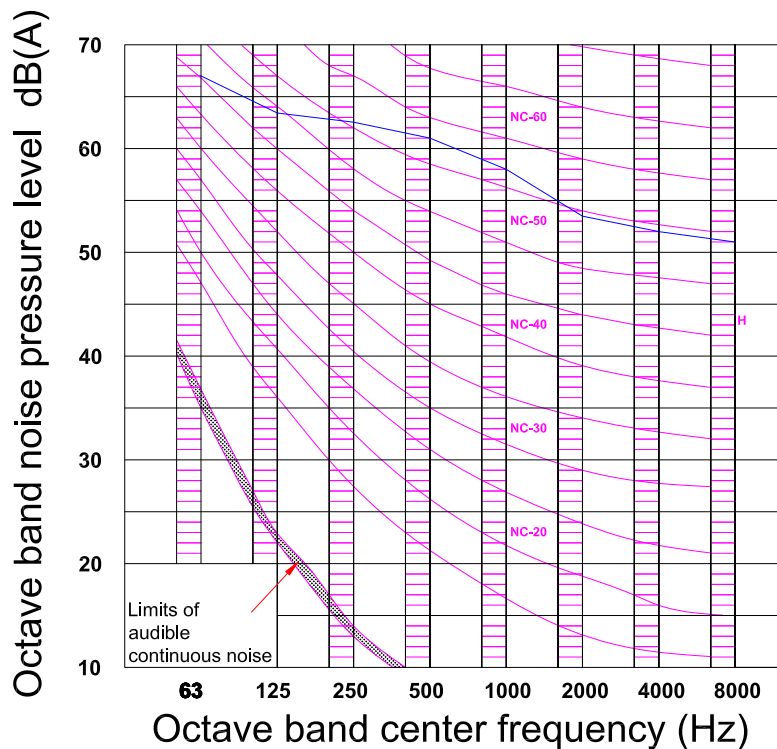

AW082MUGHA

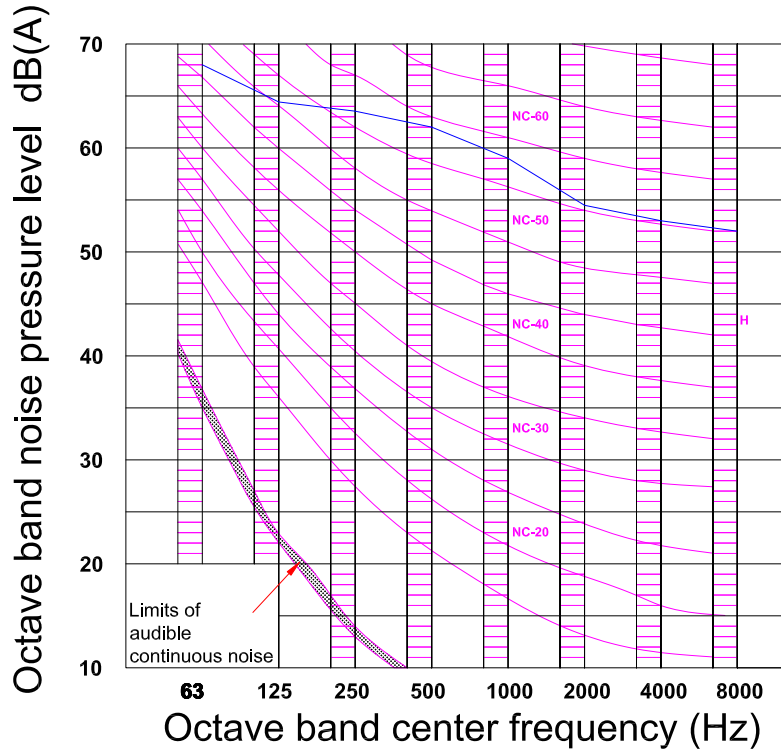

AW102MUGHA/AW10NMUGHA

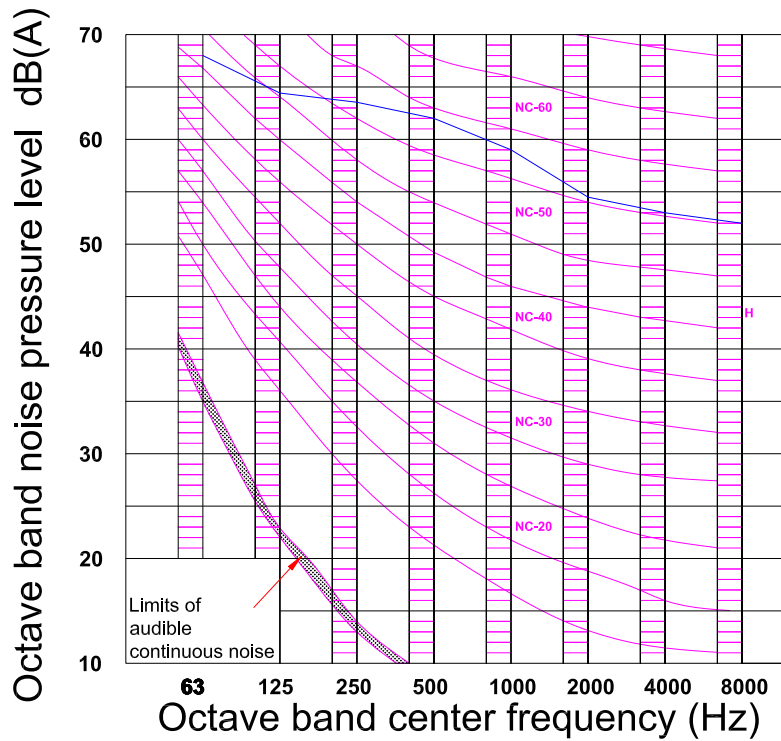

AW122MXGHA/AW12NMXGHA

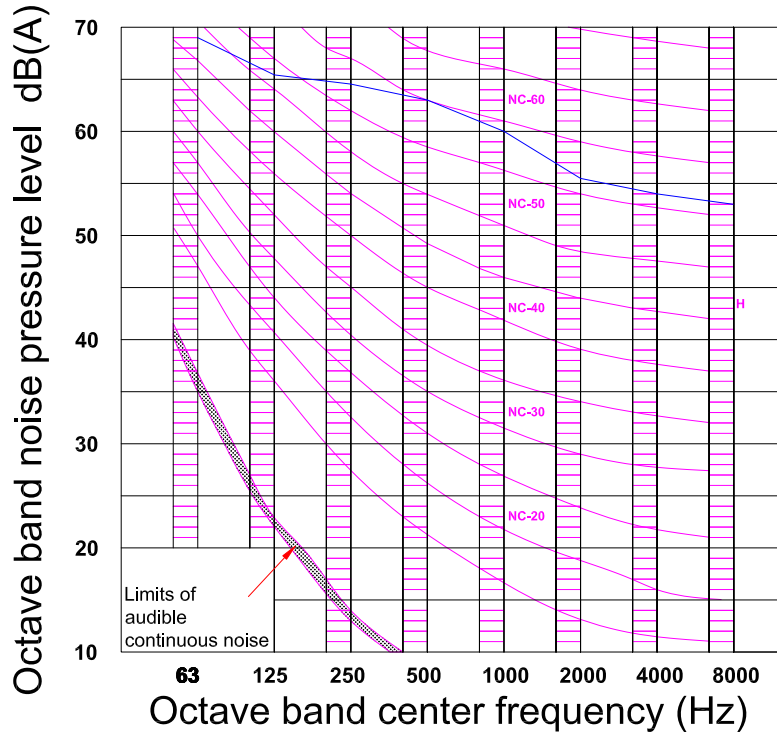

AW142MXGHA/AW14NMXGHA

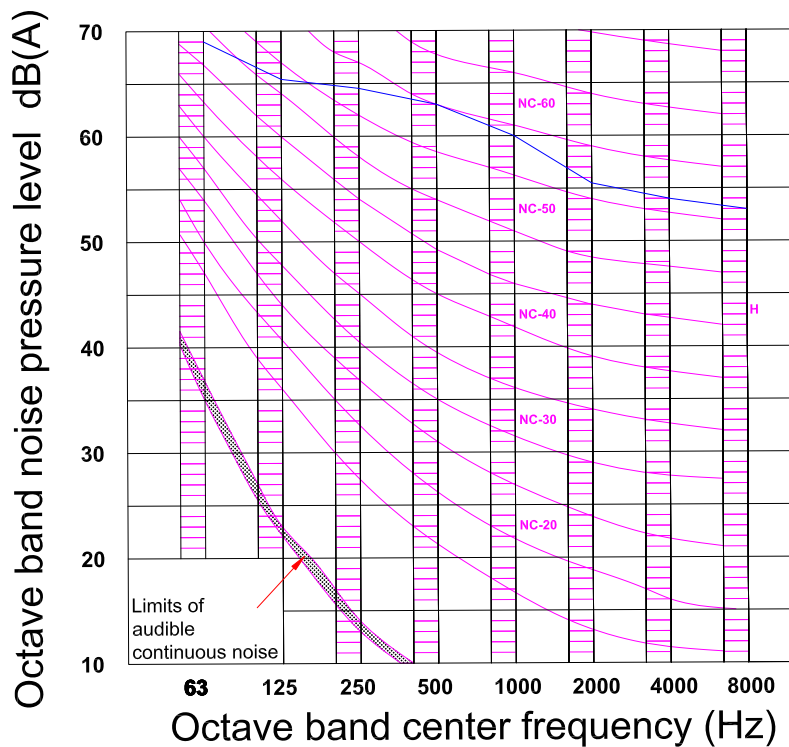

AW162MXGHA/AW16NMXGHA

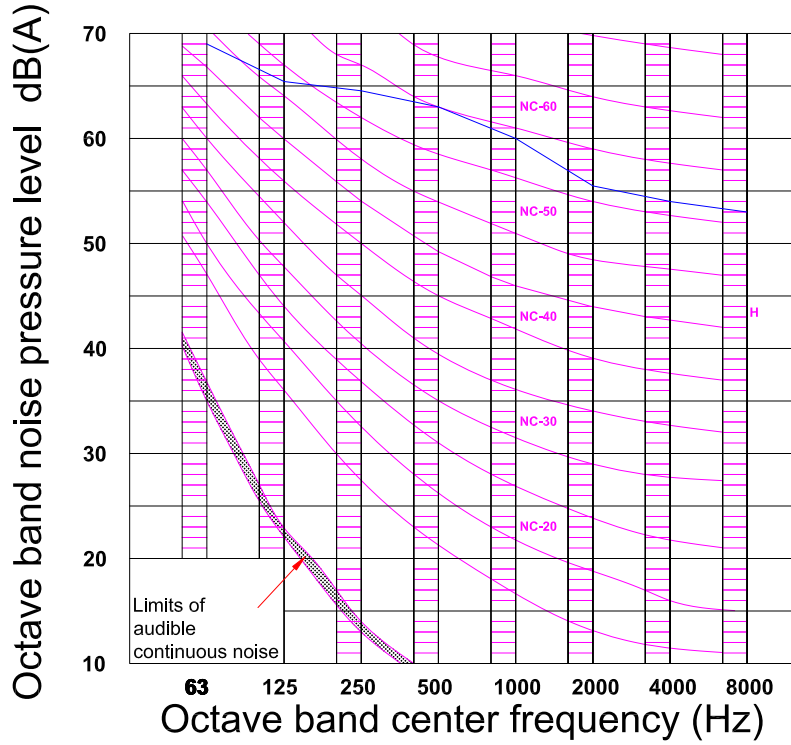

15. PCB Photos

AW042MUGHA AW062MUGHA AW082MUGHA AW102MUGHA
AW122MXGHA AW142MXGHA AW162MXGHA

Main PCB Code: 0151801061

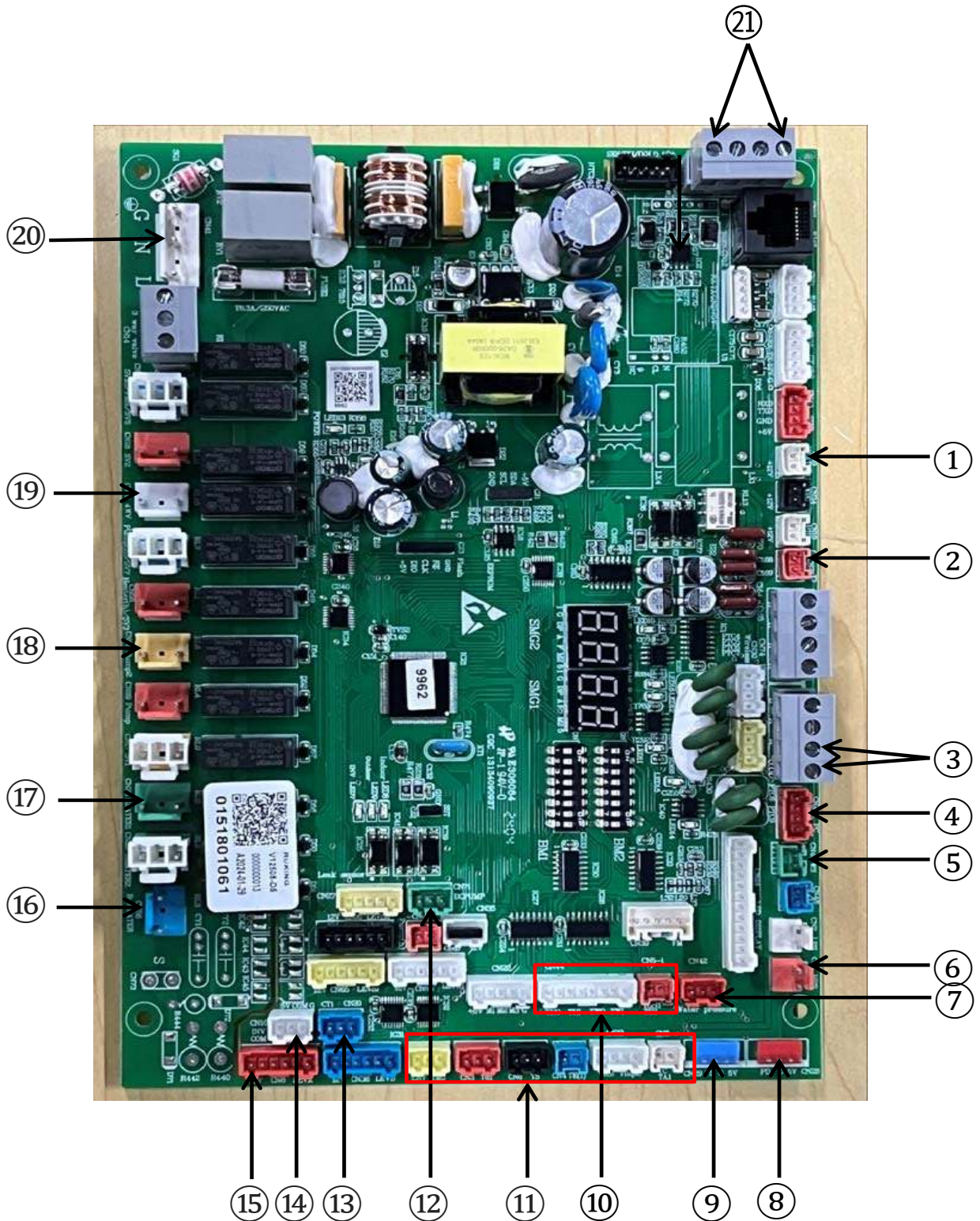

No.	Port No.	Silk No.	Full Name Description
1	CN9	HEATER1	Electric Heater Control
2	CN21	Q P	Indoor & Outdoor Units Communication
3	CN31	A B	PC Monitor(Reserved)
4	CN40	PC	PC Monitor
5	CN46	WS	FlowMeter
6	CN1	HPS	High Pressure Switch
7	CN42	Water Pressure	Water Pressure Sensor
8	CN28	PD	High Pressure Sensor
9	CN29	PS	Low Pressure Sensor
10	CN44 CN5-1	THO THI TWO TWI Toci1/TE2	Temperature Sensor
11	CN7 CN3 CN6 CN4 CN23 CN5	TA0 Td1 TS TE (1) Tsco Tliqsc TC/TA1	Temperature Sensor
12	CN71	DCPUMP	DC Water Pump Control Signal
13	CN20	CT1	CT PCB
14	CN10	INV COM	Inverter Communication
15	CN8	LEVA	Electronic Expansion Valve
16	CN56	B-HEATER	Chasis Heater
17	CN25	HEATER1	Crankcase Heater
18	CN55	Pump2	DC Water Pump Power Supply
19	CN16	4WV	Four Way Valve
20	CN41	G N L	Power Supply
21	CN32	WIFI/CANDY	Wi-Fi

AW042MUGHA AW062MUGHA

Inverter PCB Code: 0150406832BA

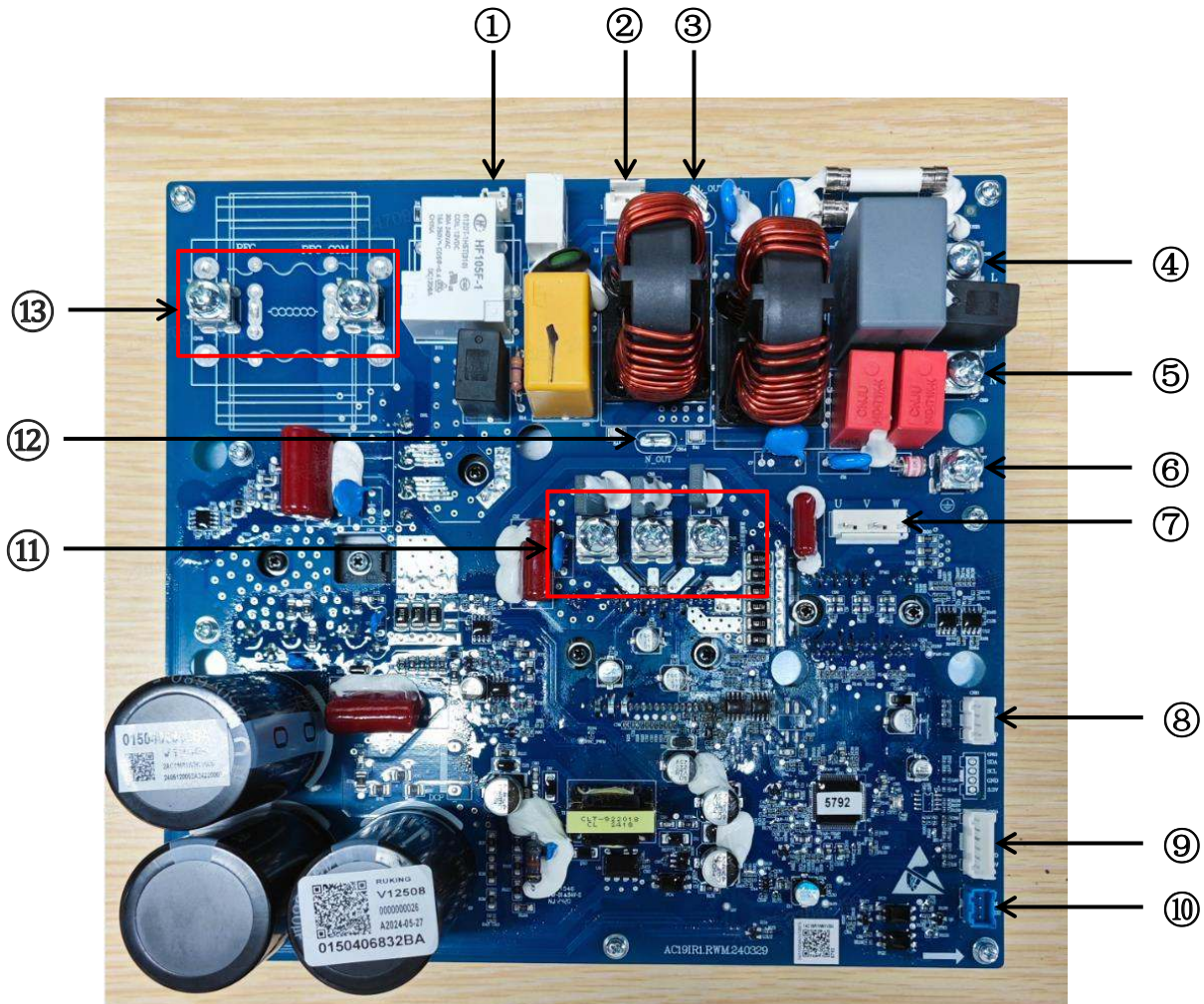



No.	Port No.	Silk No.	Full Name Description
1	CN2	/	12V Standby
2	CN3	/	Jump Wire (Reserved for Standby Function)
3	CN15	L_OUT	L Power Supply
4	CN8	L	L Power Input
5	CN9	N	N Power Input
6	CN7		Earthing Input
7	CN12	U V W	Fan Motor Input
8	CN11	/	Chip Pgoramming
9	CN10	/	Test Monitoring
10	CN1	/	Main PCB Communication
11	CN4 CN5 CN6	U V W	Compressor Output
12	CN14	N_OUT	N Power Supply
13	CN18 CN17	PFC PFC-COM	External Inductance

AW082MUGHA AW102MUGHA

Inverter PCB Code: 0150406834DA

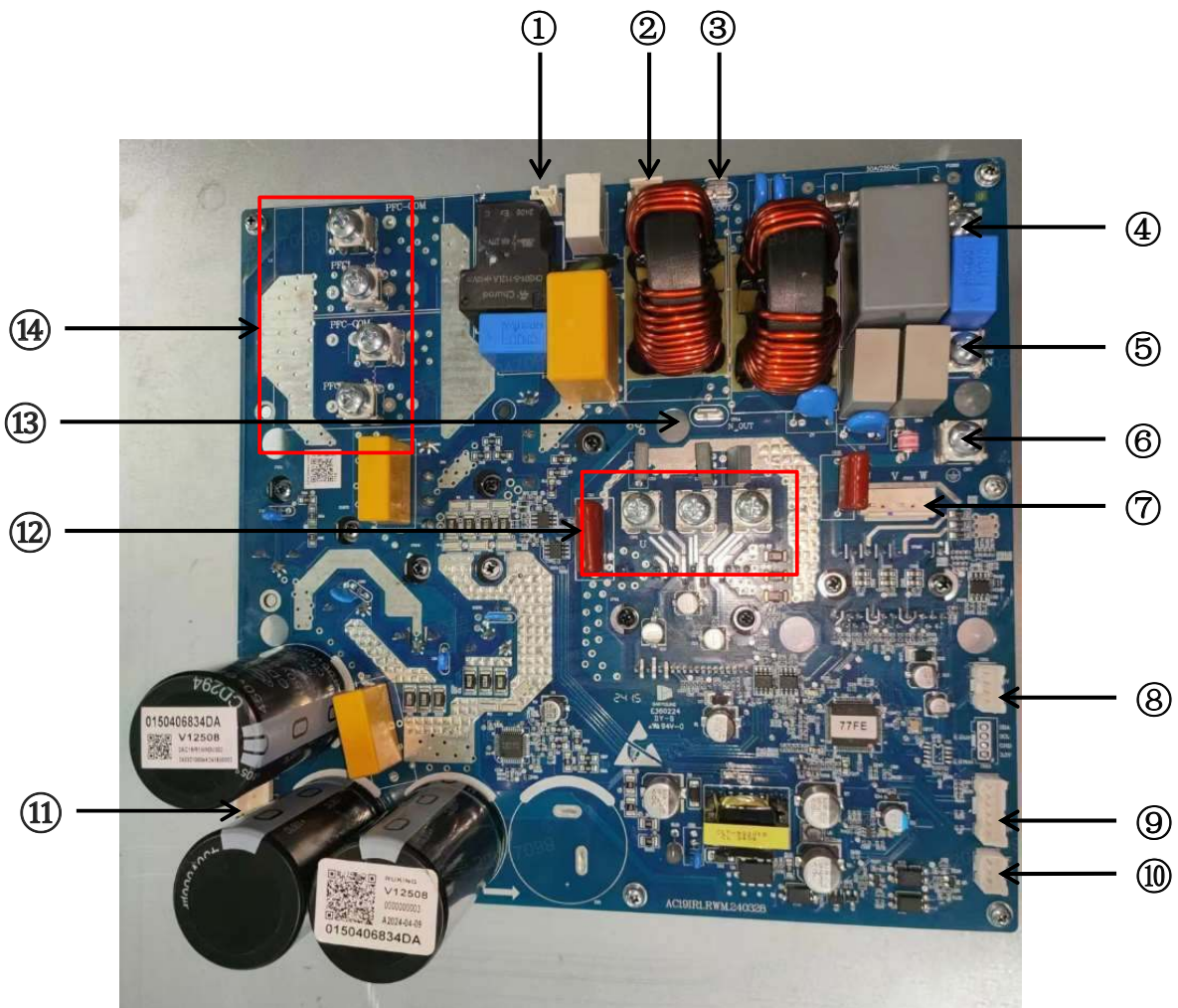
0150406834DA



No.	Port No.	Silk No.	Full Name Description
1	CN8	/	12V Standby
2	CN3	/	Jump Wire (Reserved for Standby Function)
3	CN15	L_OUT	L Power Supply
4	CN2	L	L Power Input
5	CN1	N	N Power Input
6	CN7		Earthing Input
7	CN12	U V W	Fan Motor Input
8	CN11	/	Chip Programming
9	CN10	/	Test Monitoring
10	CN9	/	Mian PCB Communication
11	CN16	N P	Compressor Output
12	CN4 CN5 CN6	U V W	DC Bus Voltage Output
13	CN14	N_OUT	N Power Supply
14	P1 P2 P3 P4	PFC-COM PFC1 PFC-COM PFC2	External Inductance

AW122MXGHA AW142MXGHA

Inverter PCB Code: 0150406834BA

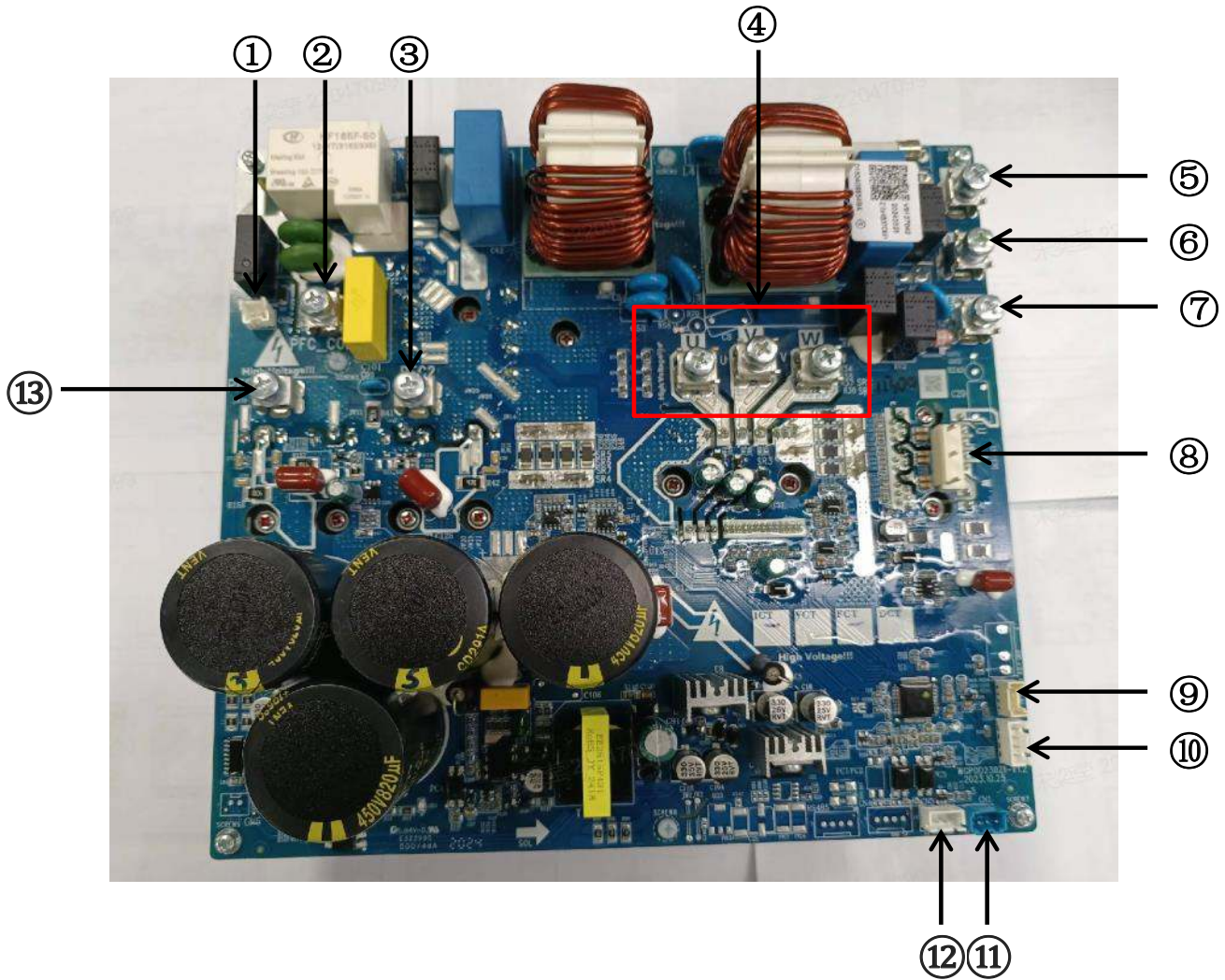

No.	Port No.	Silk No.	Full Name Description
1	CN2	/	12V Standby
2	PFC_COM	PFC_COM	External Inductance
3	PFC2	PFC2	External Inductance
4	U V W	U V W	Compressor Output
5	AC-L	AC-L	L Power Input
6	AC-N	AC-N	N Power Input
7	EARTH	EARTH	Earthing Input
8	DCFAN1	U V W	Fan Motor Output
9	CN-PC	CN-PC	Test Monitoring
10	ISP	ISP	Chip Pgoramming
11	CN1	/	Main PCB Communication
12	CN3	/	Main PCB Communication
13	PFC1	PFC1	External Inductance

AW162MXGHA

Inverter PCB Code: 0150411653

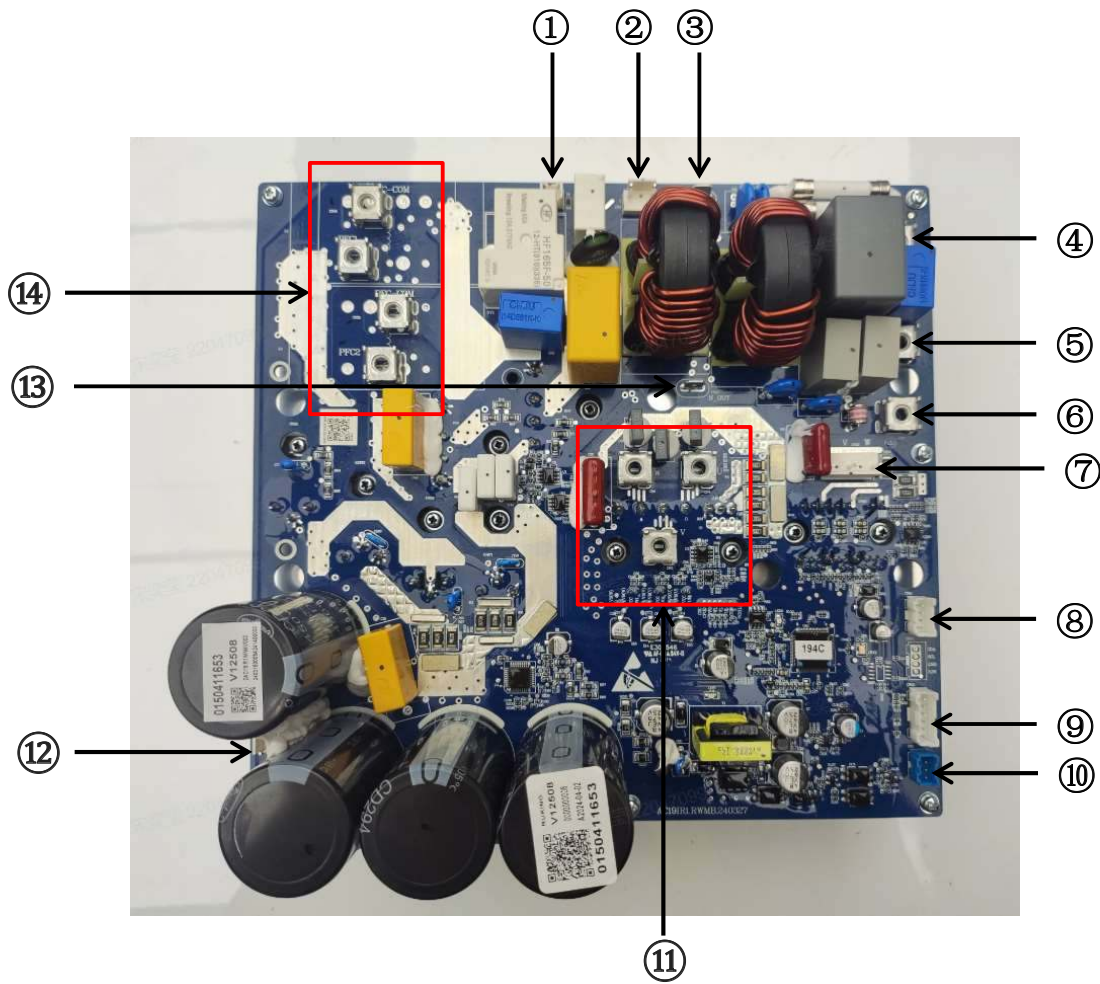

No.	Port No.	Silk No.	Full Name Description
1	CN2	/	12V Standby
2	CN3	/	Jump Wire (Reserved for Standby Function)
3	CN15	L_OUT	L Power Supply
4	CN8	L	L Power Input
5	CN9	N	N Power Input
6	CN7		Earthing Input
7	CN12	U V W	Fan Motor Output
8	CN11	/	Chip Pgoramming
9	CN10	/	Test Monitoring
10	CN1	/	Main PCB Communication
11	CN4 CN5 CN6	U V W	Compressor Output
12	CN16	N P	DC Bus Voltage Output
13	CN14	N_OUT	N Power Supply
14	CN18 PFC1 CN21 PF2	PFC-COM PFC1 PFC-COM PFC2	External Inductance

AW10NMUGHA AW12NMXGH AW14NMXGHA AW16NMXGHA

Main PCB Code: 0150405099AC 0150405099AD 0150405099AE

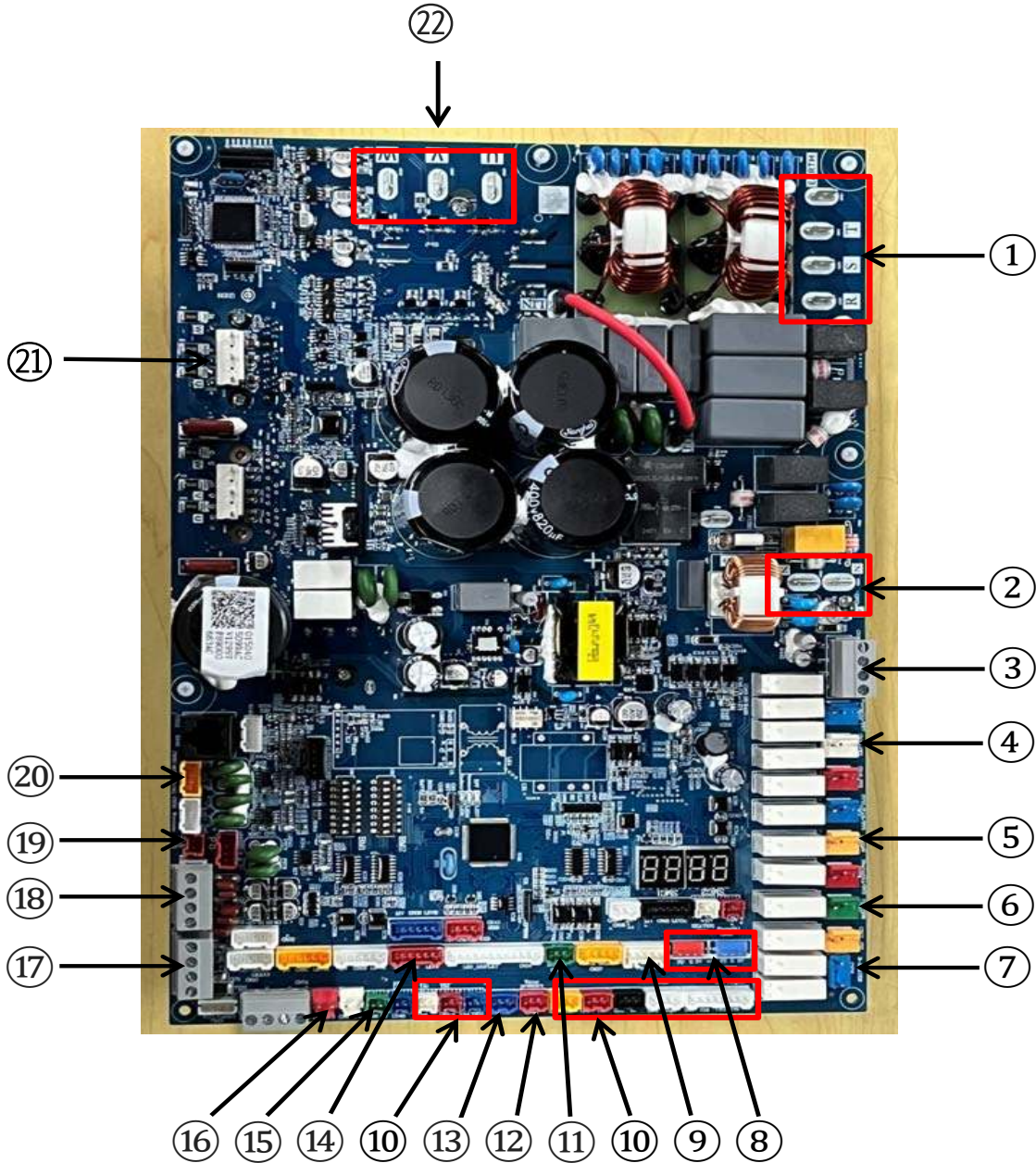

No.	Port No.	Silk No.	Full Name Description
1	CN77 CN79 CN81 CN82	R S T EARTH	Driver PCB Power Supply
2	CN93 CN90	N N	Main PCB Power Supply
3	CN14	3 way valve	Three Way Valve(Reserved)
4	CN16	4WV	Four Way Valve
5	CN55	Pump2	Water Pump
6	CN25	HEATER1	Crankcase Heater
7	CN56	B-HEATER	Chasis Heater
8	CN28 CN29	PD PS	Pressure Sensor
9	CN39	FM	Flowmeter
10	CN7 CN3 CN6 CN23 CN44	TAO Td1 TS Tsc0 Tliqsc THO THI TWO TWI	Temperature Sensor
11	CN71	DCPUMP	DC Water Pump Control Signal
12	CN42	Water pressure	Water Pressure Sensor
13	CN20	CT1	CT PCB
14	CN8	LEVA	Electronic Expansion Valve
15	CN46	WS	Flow Switch
16	CN1	HPS	Pressure Switch
17	CN15	/	Wi-Fi(Reserved)
18	CN31	/	PC Monitor(Reserved)
19	CN21	P Q	Indoor & Outdoor Communication
20	CN70	MODBUS/4G	Modbus(Reserved)
21	CN76	U V W	Fan Motor Output
22	CN86 CN87 CN88	U V W	Compressor Output

16. Dip Switch Setting

Must power off before opening the cover of the electrical control box and setting the dip switch.
In the following table, 1 is for ON and 0 is for OFF.

(1) BM1 dip switch definition:

BM1_1	Capacity control mode option	[1]	Capacity control mode option			
		0	Normal control (default)			
		1	IO board 0-10V control			
BM1_2 BM1_3 BM1_4 BM1_5	Outdoor unit models option	[2]	[3]	[4]	[5]	Outdoor unit models option
		0	0	0	0	AW042MUGHA
		0	0	0	1	AW062MUGHA
		0	0	1	0	AW082MUGHA
		0	0	1	1	AW102MUGHA/AW10NMUGHA
		1	0	0	0	AW122MXGHA/AW12NMXGHA
		1	0	0	1	AW142MXGHA/AW14NMXGHA
BM1_6	Power supply option	[6]	Power supply option			
		0	Single phase (default)			
		1	Three-phase			
BM1_7 BM1_8	Outdoor unit modes option	[7]	[8]	Outdoor unit modes option		
		0	0	Normal mode (default)		
		0	1	Power mode		
		1	0	Quiet mode		
		1	1	Performance test mode.		

(2) BM2 dip switch definition:

BM2_1 BM2_2 BM2_3	Outdoor unit model option	[1]	[2]	[3]	Outdoor unit model
		0	0	0	MONOBLOC (default)
		0	0	1	Hydro split
		0	1	0	All in One
BM2_4	Refrigerant type option	[3]	Refrigerant type option		
		0	R290 (default)		
		1	R32(Reserved)		
BM2_5~8	Reserved	Reserved (default as 0)	Reserved (default as 0)		

17. Sensor Resistance Table

1. Reference Table

No.	Spare Parts Code	Sign	Parameter	Note
1	0004000046	Ts	25°10 kΩ	Sheet 1
2	0004000047	Te1	25°10 kΩ	Sheet 1
3	0004000052	Tout2	25°10 kΩ	Sheet 1
4	0004000053	Tai	25°10 kΩ	Sheet 1
5	0004000049	T-tank	25°10 kΩ	Sheet 1
6	0004000050	T-tank2	25°10 kΩ	Sheet 1
7	0004000048	Tw1, Two	25°10 kΩ	Sheet 1
8		Thi, Tho	25°10 kΩ	Sheet 1
9	0150409004	Tao	25°10 kΩ	Sheet 1
10	0004000045	Td1	80°50 kΩ	Sheet 2

2. Sensor Resistance Table (Sheet 1)

25°10 kΩ

R25=10.00KΩ±3% B25/50= 3700K±3%

T(°C)	Rnom(KΩ)	T(°C)	Rnom(KΩ)
-40	250.4931	34	6.9733
-39	235.5181	35	6.7067
-38	221.5962	36	6.4516
-37	208.6378	37	6.2076
-36	196.5621	38	5.9740
-35	185.2972	39	5.7503
-34	174.7781	40	5.5362
-33	164.9457	41	5.3311
-32	155.7471	42	5.1346
-31	147.1341	43	4.9463
-30	139.0630	44	4.7659
-29	131.4940	45	4.5929
-28	111.8705	46	4.4271
-27	117.7198	47	4.2681
-26	111.4512	48	4.1155
-25	105.5570	49	3.9692
-24	100.0117	50	3.8287
-23	94.7917	51	3.6947
-22	89.8755	52	3.5660
-21	85.2430	53	3.4424
-20	80.8759	54	3.3237
-19	76.7571	55	3.2096
-18	72.8709	56	3.1000
-17	69.2025	57	2.9946
-16	65.7385	58	2.8933
-15	62.4662	59	2.7959
-14	59.3739	60	2.7022
-13	56.4507	61	2.6121
-12	53.6864	62	2.5253
-11	51.0715	63	2.4419

T(°C)	Rnom(KΩ)	T(°C)	Rnom(KΩ)
-10	48.5972	64	2.3615
-9	46.2552	65	2.2842
-8	44.0377	66	2.2097
-7	41.9376	67	2.1380
-6	39.9480	68	2.0689
-5	38.0627	69	2.0024
-4	36.2756	70	1.9383
-3	34.5812	71	1.8765
-2	32.9744	72	1.8169
-1	31.4500	73	1.7595
0	30.0037	74	1.7042
1	28.6310	75	1.6508
2	27.3278	76	1.5994
3	26.0904	77	1.5497
4	24.9152	78	1.5018
5	23.7987	79	1.4556
6	22.7377	80	1.4110
7	21.7294	81	1.3680
8	20.7707	82	1.3265
9	19.8592	83	1.2864
10	18.9922	84	1.2477
11	18.1673	85	1.2103
12	17.3825	86	1.1742
13	16.6355	87	1.1393
14	15.9243	88	1.1057
15	15.2472	89	1.0731
16	14.6023	90	1.0417
17	13.9879	91	1.0113
18	13.4024	92	0.9819
19	12.8445	93	0.9535
20	12.3126	94	0.9261
21	11.8055	95	0.8996
22	11.3218	96	0.8739
23	10.8604	97	0.8491
24	10.4201	98	0.8251
25	10.0000	99	0.8019
26	9.5989	100	0.7794
27	9.2160	101	0.7577
28	8.8503	102	0.7366
29	8.5010	103	0.7163
30	8.1673	104	0.6966
31	7.8483	105	0.6775
32	7.5435	106	0.6591
33	7.2520	107	0.6412

80°50 kΩ (Sheet 2)
 R80=50KΩ±3% B25/80=4450±3% M470-2

T(°C)	Rnom(KΩ)	T(°C)	Rnom(KΩ)
-40	24087.7290	33	349.3720
-39	22367.9580	34	333.5280
-38	20789.5510	35	318.5030
-37	19338.8110	36	304.1920
-36	18003.4710	37	290.5980
-35	16772.8000	38	277.7190
-34	15637.1890	39	265.4530
-33	14588.0520	40	253.8000
-32	13617.8260	41	242.6590
-31	12719.6600	42	232.1310
-30	11887.4240	43	222.0110
-29	11115.5970	44	212.4030
-28	10399.1710	45	203.3060
-27	9733.7500	46	194.6180
-26	9115.2460	47	186.3380
-25	8539.8760	48	178.3660
-24	8004.3710	49	170.9040
-23	7505.5610	50	163.6470
-22	7040.7880	51	156.8770
-21	6607.3950	52	150.3850
-20	6203.1340	53	144.1920
-19	5825.8580	54	138.2840
-18	5473.5220	55	132.6470
-17	5144.3890	56	127.2660
-16	4836.8240	57	122.1290
-15	4549.1900	58	117.2230
-14	4280.2620	59	112.5390
-13	4028.5060	60	108.0630
-12	3792.9000	61	103.7870
-11	3572.3190	62	99.6990
-10	3365.7420	63	95.7930
-9	3172.0450	64	92.0570
-8	2990.6130	65	88.4850
-7	2820.4240	66	85.0680
-6	2660.7640	67	81.7990
-5	2511.0190	68	78.6710
-4	2370.4730	69	75.6770
-3	2238.5130	70	72.8110
-2	2114.5260	71	70.0670
-1	1998.1030	72	67.4390
0	1888.7330	73	64.9210
1	1785.8020	74	62.5100
2	1689.1060	75	60.1980
3	1598.1350	76	57.9840
4	1512.5810	77	55.8600
5	1432.0350	78	53.8250

T(°C)	Rnom(KΩ)	T(°C)	Rnom(KΩ)
6	1356.1910	79	51.8720
7	1284.7430	80	50.0000
8	1217.4850	81	48.2040
9	1154.1120	82	46.4800
10	1094.3160	83	44.8260
11	1037.9950	84	43.2390
12	984.8440	85	41.7140
13	934.7580	86	40.2510
14	887.4320	87	38.8450
15	842.7640	88	37.4950
16	800.6520	89	36.1980
17	760.7880	90	34.9520
18	723.1730	91	33.7550
19	687.6020	92	32.6030
20	653.9730	93	31.4960
21	622.0820	94	30.4320
22	592.0300	95	29.4090
23	563.5120	96	28.4250
24	536.6300	97	27.4770
25	511.0760	98	26.5660
26	486.8510	99	25.6890
27	463.9550	100	24.8450
28	442.2850	101	24.0330
29	421.7400	102	23.2500
30	402.2170	103	22.4970
31	383.6140	104	21.7720
32	366.0330	105	21.0730

18. Accessories

	AW042MUGHA AW062MUGHA AW082MUGHA AW102MUGHA AW10NMUGHA	AW122MXGHA AW142MXGHA AW162MXGHA AW12NMXGHA AW14NMXGHA AW16NMXGHA	Description	Spare Parts No.
Drainage elbow	9	10	Water drainage of outdoor unit drain pan.	0010207576
Rubber cushion	6	6	Reduce vibration.	0150205886
Wired controller	1	1		0150402285F
Water filter	1	1	Filter water	0150751113
Installation manual	1	1	Refer to this manual for installation.	/
Temperature sensor	3	3	To detect Zone1 and Zone2 water tank temperature.	0150408957



Drainage elbow



Rubber cushion



Wired controller



Water filter



Temperature sensor



ATW-A03N

19. Recommended External Device Specification

No.	Part		Specifications
1	Two way valve kit *Cooling model	Electromotoric Actuator	AC230V, 12 VA
		2-port Valve	
2	Room thermostat	Wired	AC230V
		Wireless	
3	Mixing valve	-	AC230V, 6VA
4	Pump	-	AC 230V, 0.6 A max

20. Manual Updates Versions

This part will show the update versions of this Manual.

Version Code	Description	Date
SYJS-08-2024 REV.A Edition: 2024-08-29	Modify Heating and DHW Water Outlet Temperature	2024/8/29
SYJS-08-2024 REV.A Edition: 2024-08-29	Modify Heating Capacity table	2024/8/29
SYJS-08-2024 REV.A Edition: 2024-08-29	Modify wiring diagram	2024/8/29
SYJS-07-2024 REV.B Edition: 2024-07-31	Modify the format of the sensor resistance table	2024/7/31
SYJS-07-2024 REV.B Edition: 2024-07-31	Modify the Operation Limits delivery leaving curve	2024/7/31
SYJS-07-2024 REV.B Edition: 2024-07-31	Change PCB Photos and Port No.	2024/7/31
SYJS-07-2024 REV.B Edition: 2024-07-31	Change Heating Capacity	2024/7/31
SYJS-07-2024 REV.B Edition: 2024-07-31	Change Wiring Diagrams	2024/7/31
SYJS-07-2024 REV.B Edition: 2024-07-31	Add All in One dip switch	2024/7/31
SYJS-07-2024 REV.B Edition: 2024-07-29	Change Certificates and Regulations	2024/7/31

Haier Commercial Air Condition

ADDRESS: No.1 Haier Road, Hi-tech Zone, Qingdao 266101 P.R.China

Web: [Http://www.haier.com](http://www.haier.com)