

Haier

More Creation, More Possibilities

Haier

HVAC Solutions

A2W

Build It Yourself Installation Manual

2025/26



CONTENTS

1.0

- 1.0. Outdoor unit & ATW-A03 N Connection
- 1.1. Electrical Wiring / Connections
 - 1.1.1. Single phase installation – 1 ph Outdoor unit
 - 1.1.2. Three phase installation - 3 ph-ODU
 - 1.1.3. Electrical connection for ATW-A03 N
 - 1.1.4. Wired controller connection
- 1.2. Connection between outdoor unit and ATW-A03N

2.0

- 2.0. Zone 1
 - 2.1. Zone 1 Without buffer tank
 - 2.1.1. Simplified hydraulic diagram
 - 2.1.2. Controller setting
- 2.2. Zone 1 With buffer tank
 - 2.2.1. Simplified hydraulic diagram
 - 2.2.2. Connections
 - 2.2.3. Simplified connection diagram
 - 2.2.4. Controller Settings

3.0

- 3.0. Zone 2
 - 3.1. Simplified hydraulic diagram
 - 3.2. Water temperature sensor for zone 2
 - 3.3. Simplified Connection Diagram
 - 3.4. Controller settings

4.0

- 4.0. Domestic Hot Water
 - 4.1. DHW installation
 - 4.1.1. Simplified hydraulic diagram
 - 4.1.2. Connections
 - 4.1.3. Simplified connection diagram
 - 4.1.4. Controller settings
 - 4.2. DHW + 3-way valve for heating & cooling installation
 - 4.2.1. Simplified hydraulic diagram
 - 4.2.2. Simplified Connection Diagram
 - 4.2.3. Controller settings

5.0

- 5.0. Auxiliary Heating Source Connection
 - 5.1. Electrical Heater
 - 5.1.1. Simplified hydraulic diagram
 - 5.1.1.1. Without buffer tank
 - 5.1.1.2. With buffer tank
 - 5.1.2. Connections
 - 5.1.3. Simplified connection diagram
 - 5.1.3.1. Without buffer tank
 - 5.1.3.2. With buffer tank
 - 5.1.4. Controller settings
 - 5.2. Boiler
 - 5.2.1. Simplified hydraulic diagram
 - 5.2.1.1. Without buffer tank
 - 5.2.1.2. With buffer tank
 - 5.2.2. Connections

- 5.2.3. Simplified connection diagram
 - 5.2.3.1. Without buffer tank
 - 5.2.3.2. With buffer tank
- 5.2.4. Controller settings
- 5.3. Bivalent
 - 5.3.1. Simplified hydraulic diagram
 - 5.3.1.1. Without buffer tank
 - 5.3.1.2. With buffer tank
 - 5.3.2. Connections
 - 5.3.3. Simplified connection diagram
 - 5.3.3.1. Without buffer tank
 - 5.3.3.2. With buffer tank
 - 5.3.4. Controller settings

6.0

- 6.0. SG Ready - smart grid SG Ready
- 6.1. Connections
- 6.2 Controller settings

7.0

- 7.1. Cascade
 - 7.1. Simplified hydraulic diagram
 - 7.1.1. Without DHW
 - 7.2. Connection
 - 7.3. Simplified connection diagram
 - 7.4. Connection
 - 7.5. Controller settings

8.0

- 8.0. Cascade

9.0

- 9.1. Third-party controller switch signal
 - 9.1.1. TYPE 1 - most commonly used system
 - 9.1.2. Third-party controller switch signal – TYPE 2
 - 9.1.3. Controller settings

10.0

- 10.0. Annexes

11.0

- 11.0. Appendix

1.0. OUTDOOR UNIT & ATW-A03 N CONNECTION



1.1. ELECTRICAL WIRING/CONNECTIONS

1.1.1. Single phase installation - 1ph-ODU

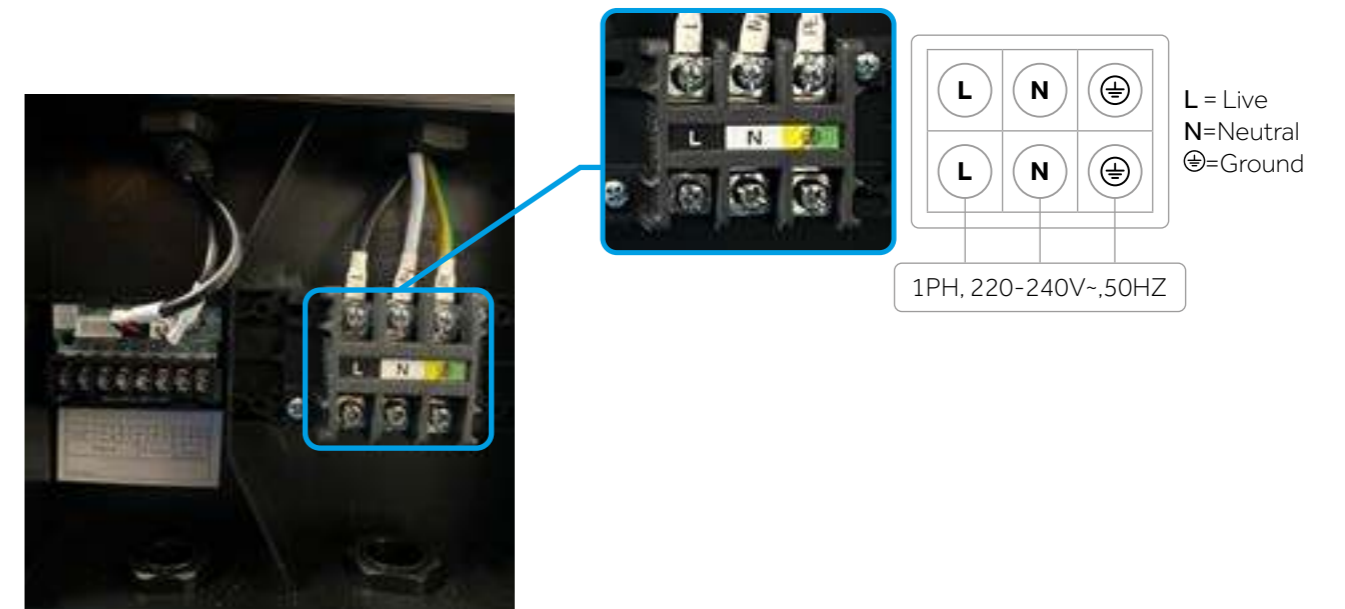

ODU HYDRO SPLIT

- AW042HUGHA; AW062HUGHA;
- AW082HUGHA; AW102HUGHA;
- AW122HVGHA; AW142HVGHA;
- AW162HVGHA; AW032HSGHA;
- AW052HSGHA

1.1. ELECTRICAL WIRING/CONNECTIONS

1.1.2 Three-phase installation - 3ph-ODU

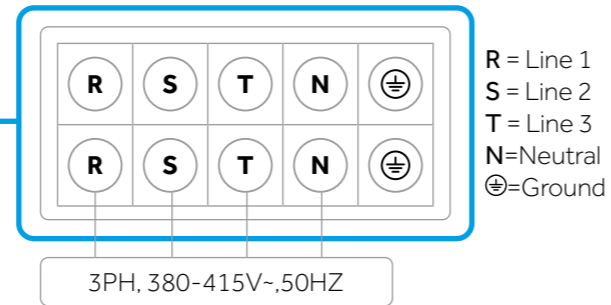

R = Line 1
S = Line 2
T = Line 3
N = Neutral
⊕ = Ground

ODU MONOBLOC:
AW10NMUGHA AW12NMUGHA
AW14NMUGHA AW16NMUGHA

1.1.3. Electrical connection for ATW-A03 N - always 240V single phase



Inner

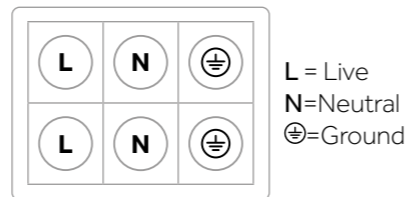

1.1.4 Wired controller connection

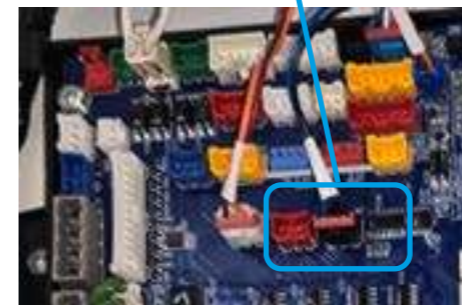
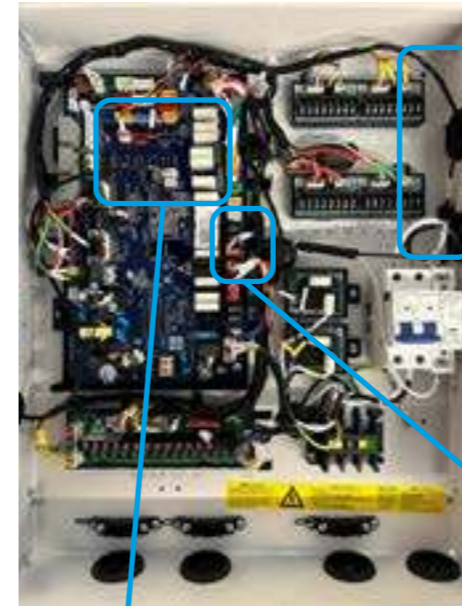

1.2. CONNECTION BETWEEN OUTDOOR UNIT AND ATW-A03 N

Outdoor Unit

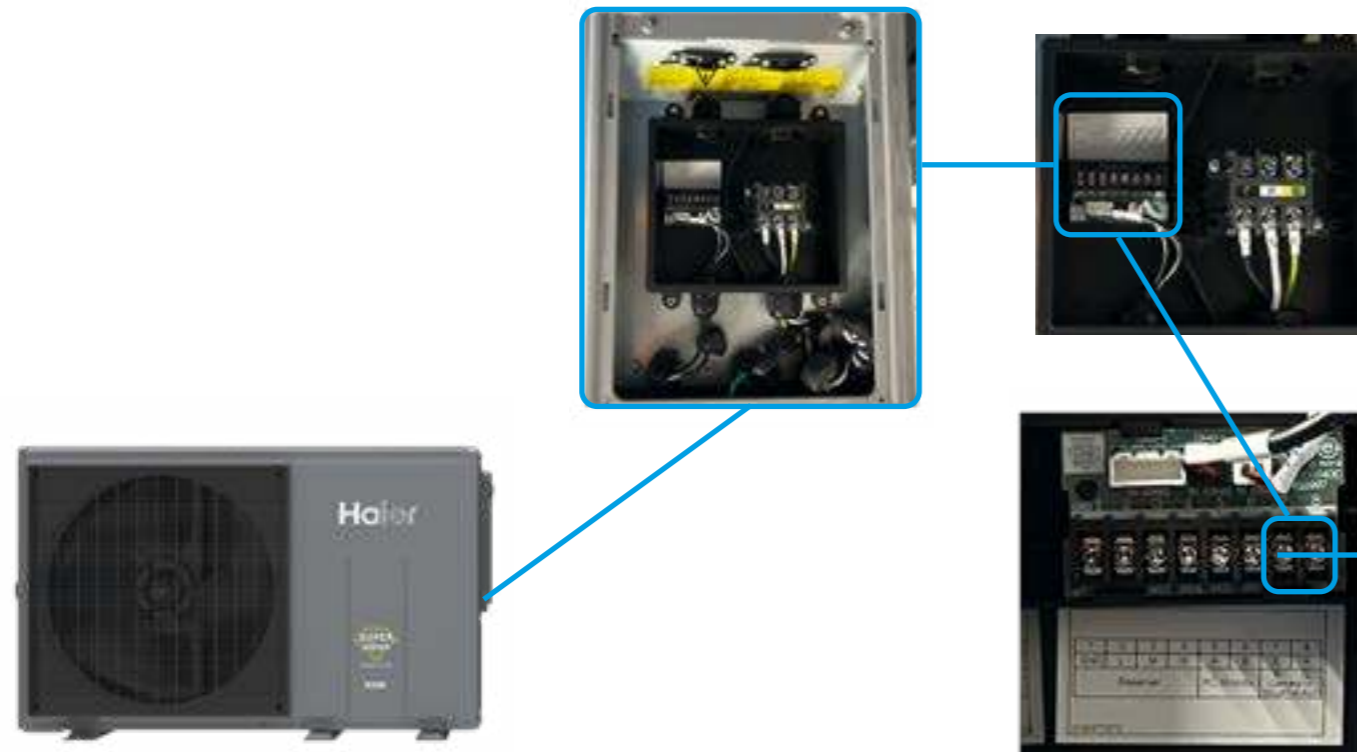

Connection Board 1 - Outdoor Unit

1	2	3	4	5	6	7	8
GND	L	M	H	A	B	X	Y
Reserved				PC Monitoring		PQ	

Connection Board 4 - Indoor unit ATW-A03

25	26	27	28	29	30	31	32
GND	L	M	H	A	B	X	Y
SG Signal		EVU Signal		Controller A/B		PQ	

Connect a 2 core communication cable from 7(X) and 8(Y) of Board 1 of the outdoor unit to 31 (X) and 32 (Y) Board 4 of the Indoor unit ATW-A03

The interconnection bus between Outdoor unit and ATW-A03N, must be done with a shielded cable of 2x0,75mm.

Note in the middle of the blue PCB a green and red light flashes if the communication is ok. If the LED's stop flashing outdoor unit is switched off.

Indoor unit ATW-A03

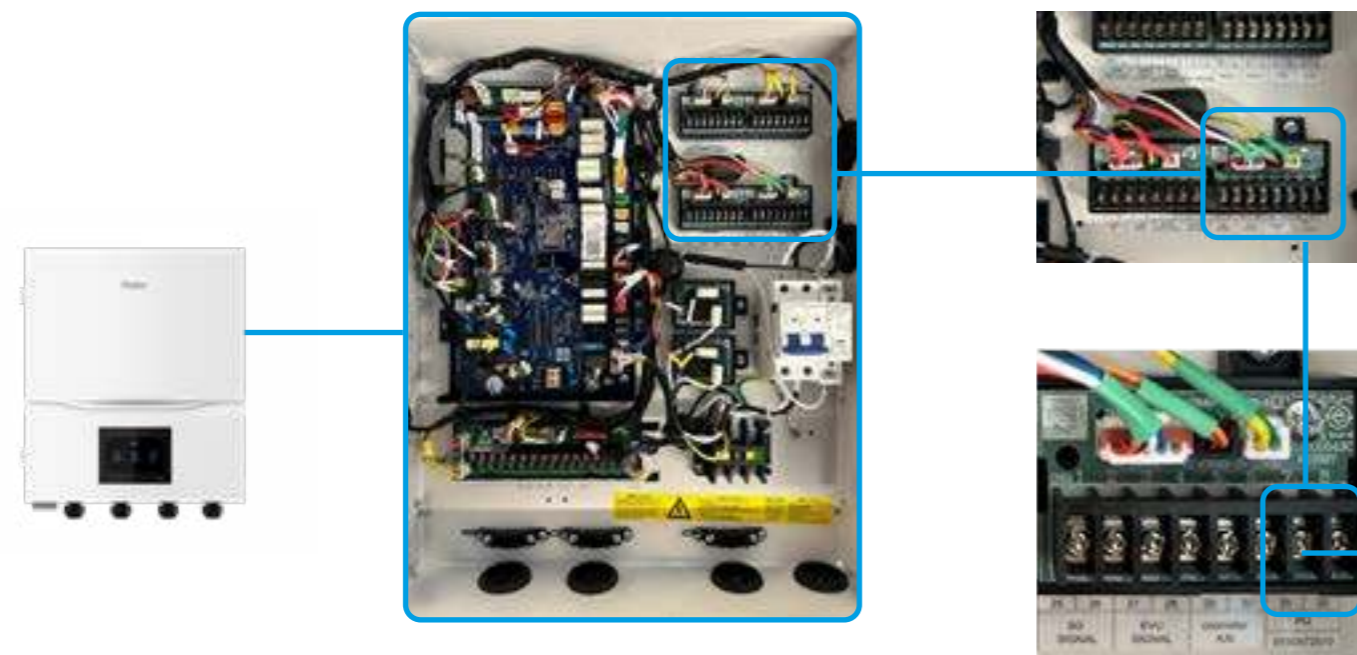

Connection Board 4

2.0. ZONE 01

This chapter is designed to show you how to install a single-zone Haier heat pump. Please note that you will need to decide how you wish to control the system; see Chapter 9 for control options. Read this chapter alongside Chapter 4 if you also want to heat the domestic hot water.

2.1. ZONE 1 WITHOUT BUFFER TANK

This chapter explains how to install the Haier heat pump without a buffer tank. This chapter demonstrates how to install the system with a single heating zone. Please note that you will need to decide on the control method; see Chapter 9 for more information. Combine this chapter with Chapter 4 if you also want to heat domestic hot water.

2.1.1 SIMPLIFIED HYDRAULIC DIAGRAM

Heating only system no buffer

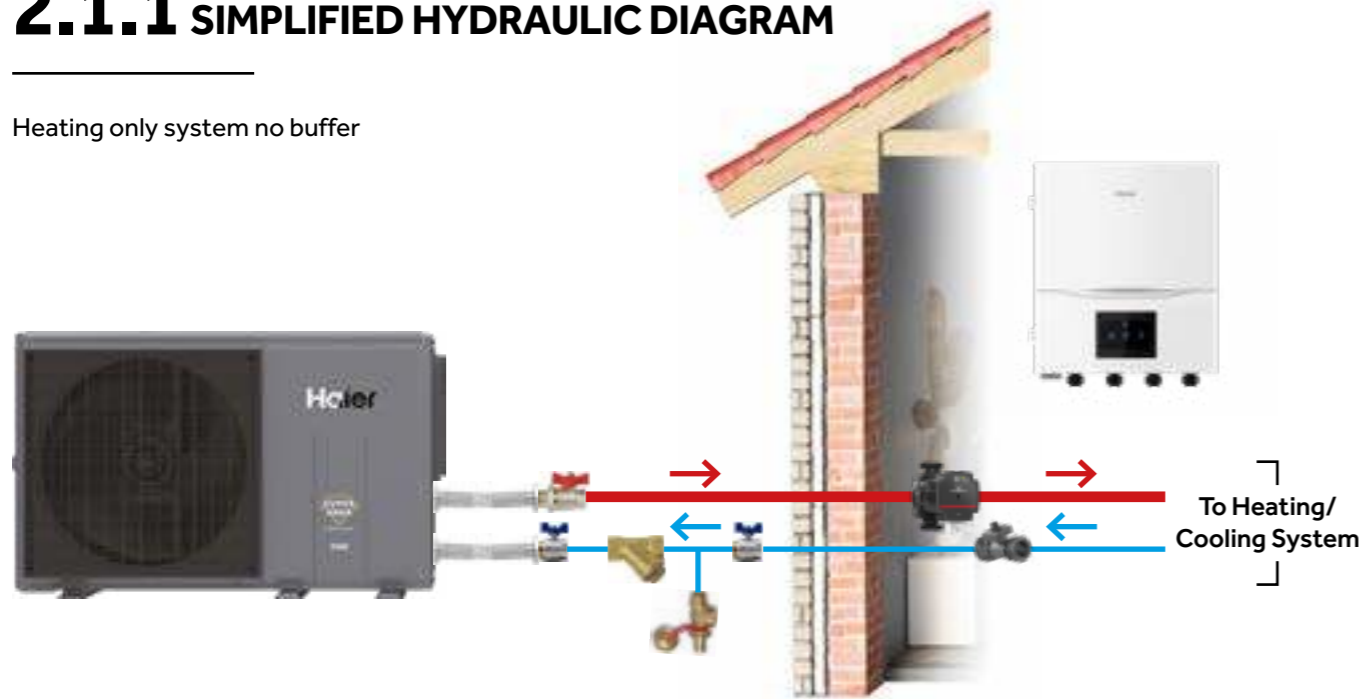

	Flexible hose pipe		Delivery water flow
	Ball Valve		Return water flow
	Ball Valve		
	Water filter		
	Drain Valve		

ALL THE DIAGRAMS AND THE ACCESSORIES ARE ONLY AN EXAMPLE OF THE INSTALLATION AND HAVE TO BE CARRIED OUT IN ACCORDANCE WITH LOCAL REGULATIONS. FOR ELECTRICAL CONNECTIONS REFER TO POINT 1.0.

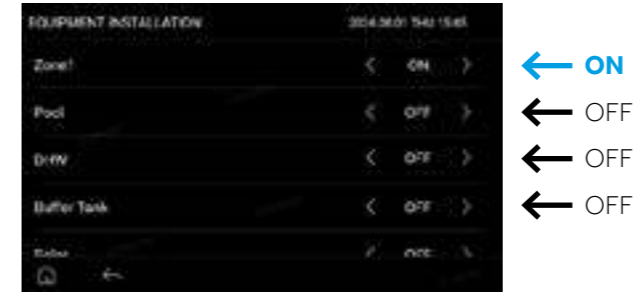

*** SELECT ON TO ACTIVATE ZONE 1**

Function	Parameter Range	Settings
Zone 1	ON/OFF	ON

2.1.2. Controller Setting

Equipment Installation main settings



1



2



3

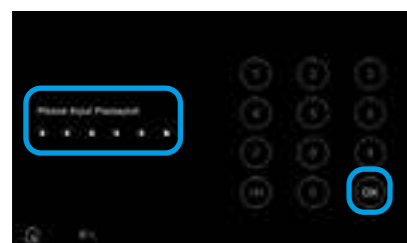

4 * Password "841226" OK



5

2.1.2. CONTROLLER SETTING

System Installation main settings



1



2



3



4 * Password "841226" OK



5

Equipment Installation main settings



← Main Controller * SELECT THE CONTROL MODE FOR ZONE 1

Function	Parameter Range	Settings
Control Mode of Zone1	Main controller, Third party controller	Main controller



← 27°C
← 6°C *ENTER DELTA T° FOR HEATING ON

Function	Parameter Range	Settings
ΔT for Heating On	0 -15 °C	6°C



← 5°C *ENTER DELTA T° FOR COOLING ON

Press "house" to return to main menu

Function	Parameter Range	Settings
ΔT for Cooling On	0 -15 °C	5°C

*PARAMETERS TO BE CHANGED ARE MARKED IN BOLD BLUE.

2.2. ZONE 1 WITH BUFFER TANK

This chapter is designed to show you how to install the Haier Heat pump with a buffer tank. In this configuration we show only 1 zone of heating, after the buffer, this zone is controlled by the Haier system. Note you will need to choose how you wish to control the system see chapter 9 for control. Combine this chapter with chapter 4 if you also want to heat the Domestic hot water.

2.2.1. SIMPLIFIED HYDRAULIC DIAGRAM

2.2.1. Heating only with a buffer tank / hydraulic separation

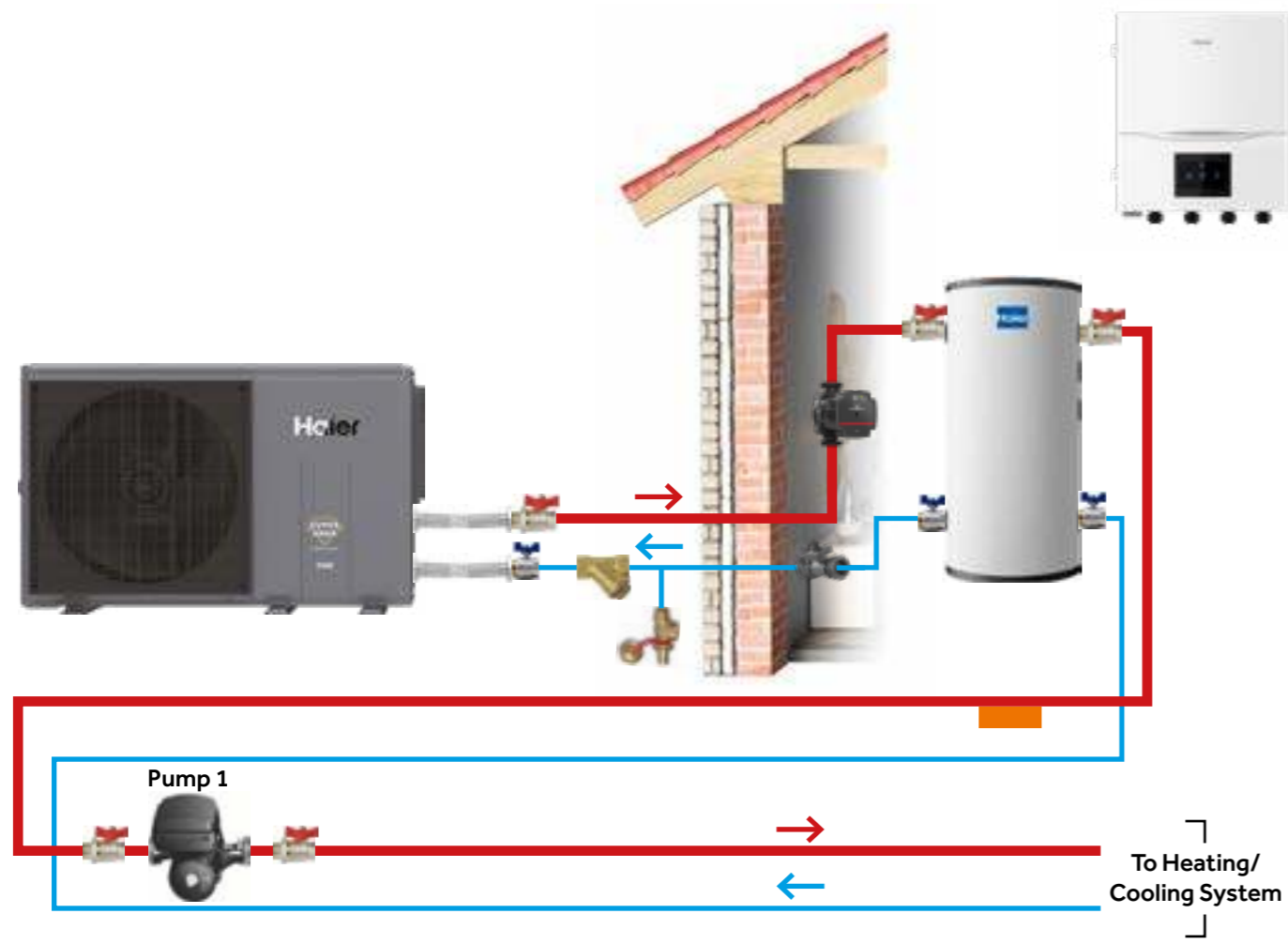

	Flexible hose pipe		Buffer Tank
	Ball Valve		Water pump
	Ball Valve		Delivery water flow
	Water filter		Return water flow
	Drain Valve		

Note: The unit must operate with the minimum system volume, see annexe at end of manual.

ALL THE DIAGRAMS AND THE ACCESSORIES ARE ONLY AN EXAMPLE OF THE INSTALLATION AND HAVE TO BE CARRIED OUT IN ACCORDANCE WITH LOCAL REGULATIONS.

FOR ELECTRICAL CONNECTIONS REFER TO POINT 1.0.

2.2.2. CONNECTIONS

Water temperature sensor for Zone 1

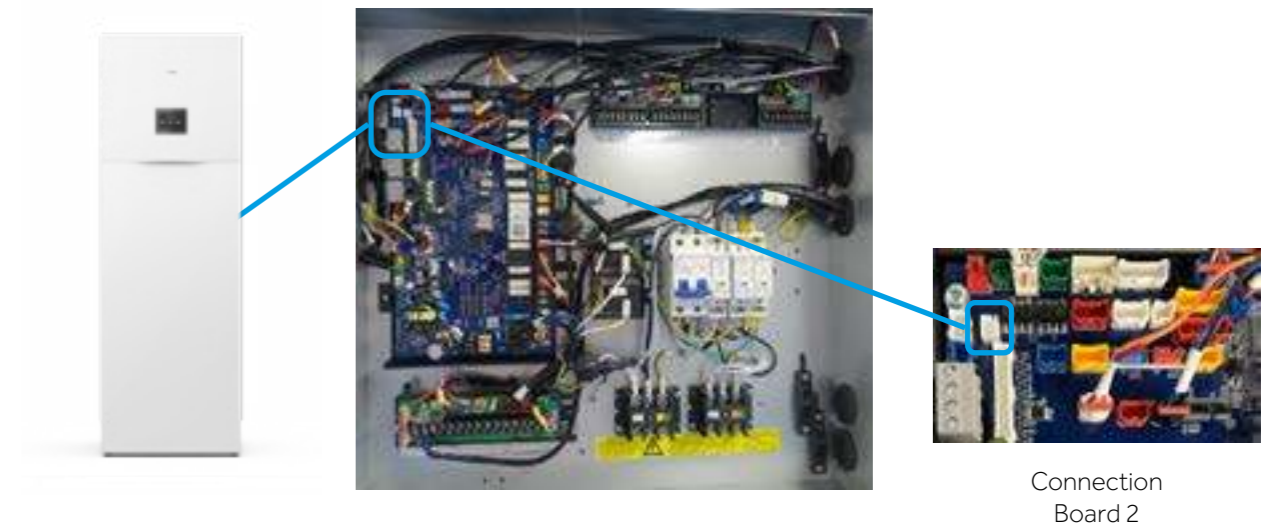

Connection Board

9	10	11	12	13	14	15	16
GND	L	M	H	A	B	X	Y
TW_zone_1		TW_zone_2		STOP		T_out2	

NOTE YOU CAN USE EITHER ZONE 1 SENSOR TW_ZONE 1 OR THE WATER SENSORS IN THE OUTDOOR UNIT TO CONTROL THE HEAT PUMP.

2.2.2. SIMPLIFIED HYDRAULIC DIAGRAM

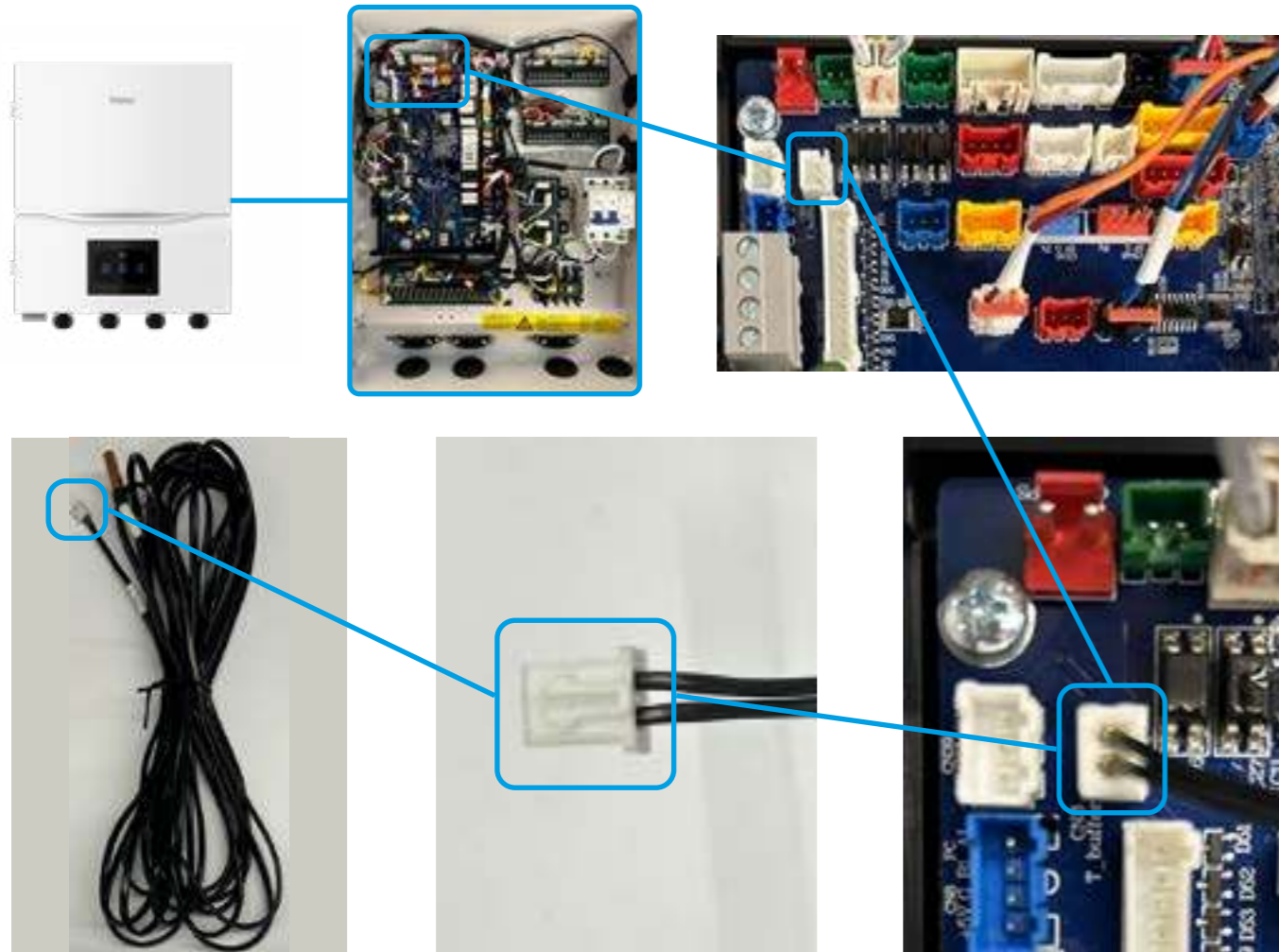

* You must use the sensor with the white plug.

*** T-BUFFER IS NOT MANDATORY**

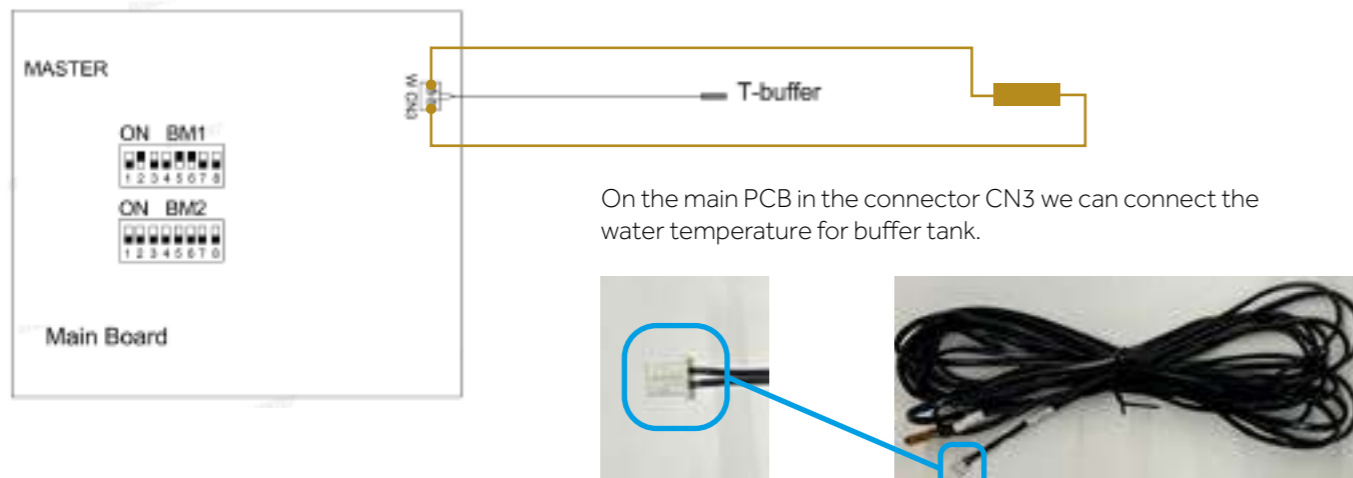

On the main PCB in the connector CN3 we can connect the water temperature for buffer tank.

IT'S POSSIBLE TO SET THE UNIT TO OPERATE TO CONTROL THE BUFFER TEMPERATURE ONLY. IF YOU WANT TO DO THIS YOU CAN INSTALL A BUFFER CONTROL SENSOR.

2.2.3. SIMPLIFIED HYDRAULIC DIAGRAM

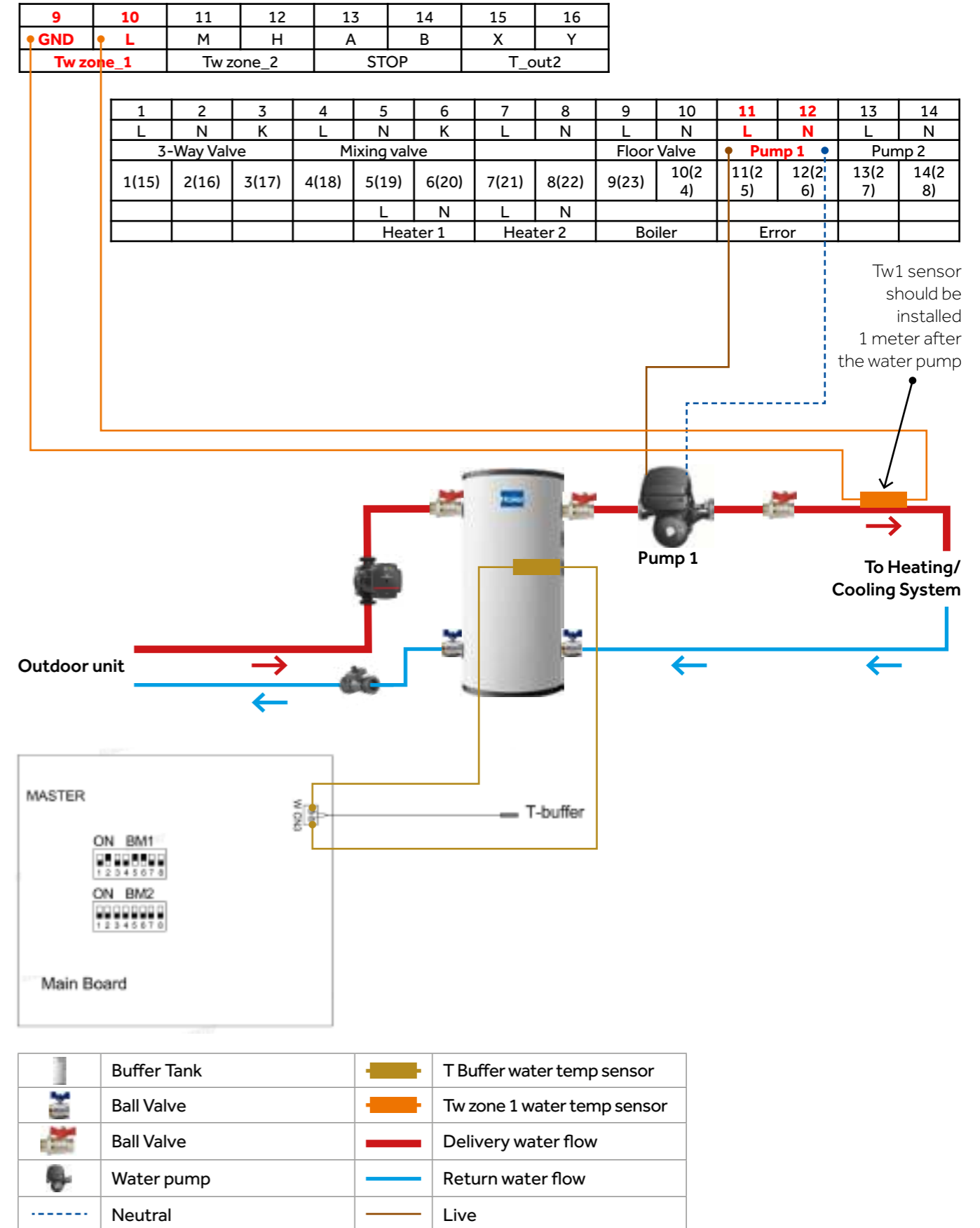

2.2.4. CONTROLLER SETTINGS

Equipment Installation main settings

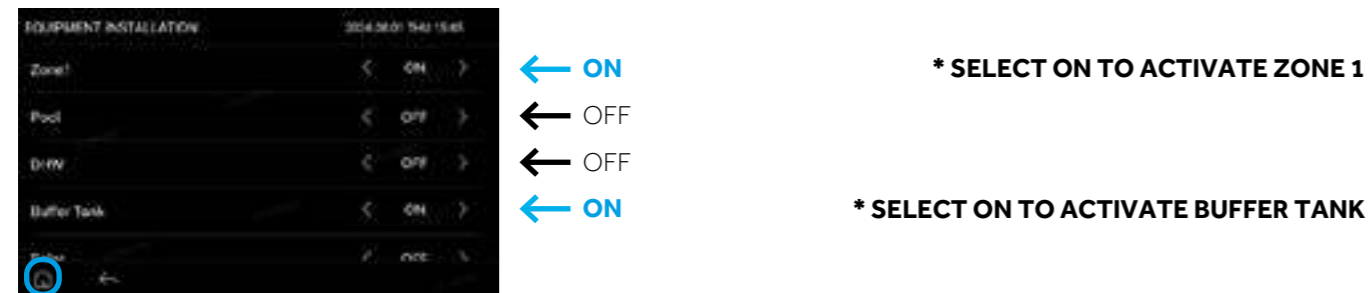
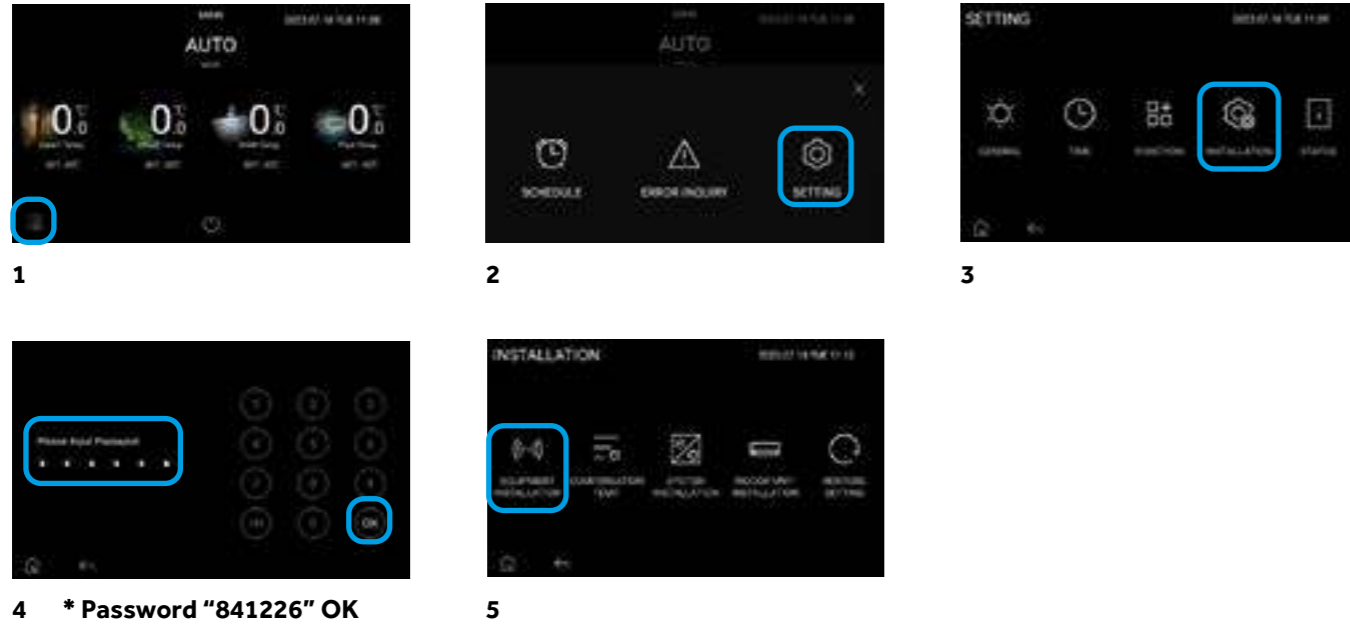

Press "house" to return to main menu

Function	Parameter Range	Settings
Zone 1	ON/OFF	ON
Buffer Tank	ON/OFF	ON

2.2.4. CONTROLLER SETTINGS

System Installation main settings

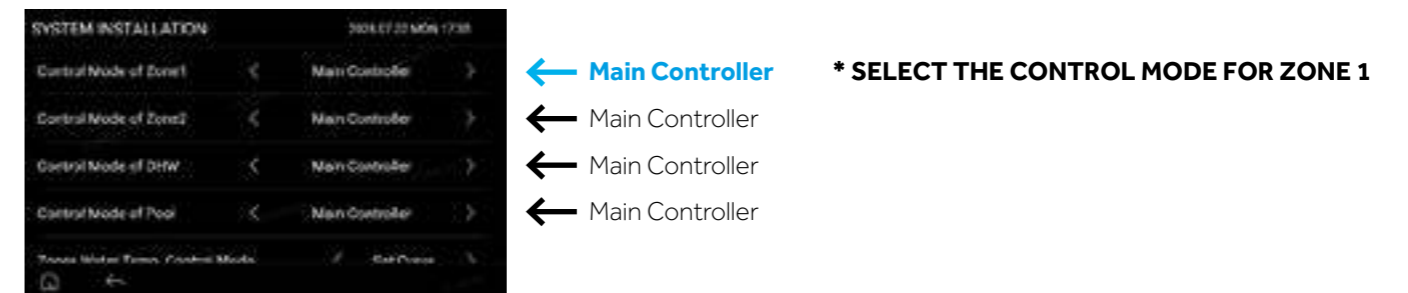

Function	Parameter Range	Settings
Control Mode of Zone 1	Main controller Third party controller	Main controller

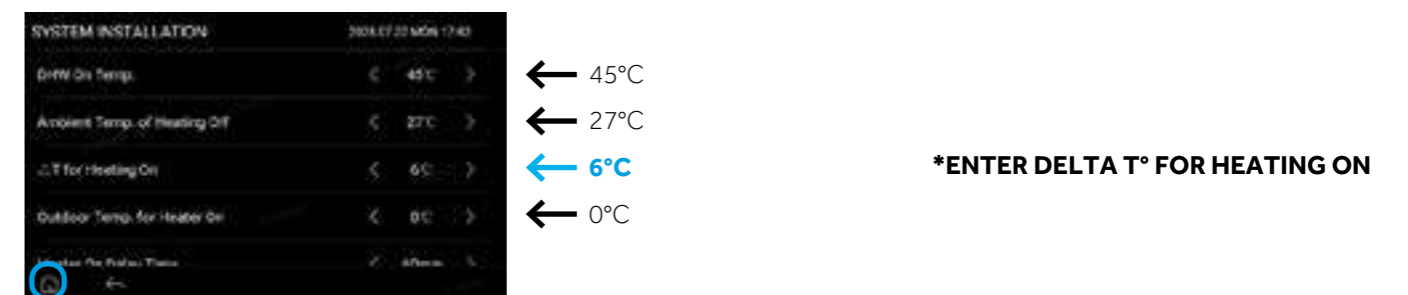

Press "house" to return to main menu

Function	Parameter Range	Settings
ΔT for Heating On	0 - 15°C	6°C

3.0. ZONE 2 - MULTIPLE ZONES

This chapter is designed to show you how to install a Haier heat pump with a buffer tank. In this configuration, it is possible to add two zones of heating after the buffer; these are controlled by the Haier system. Please note that you will need to decide how you wish to control the system; see Chapter 9 for more information. Combine this chapter with Chapter 4 if you also want to heat the domestic hot water.

3.1. SIMPLIFIED HYDRAULIC DIAGRAM

Heating multiple zones

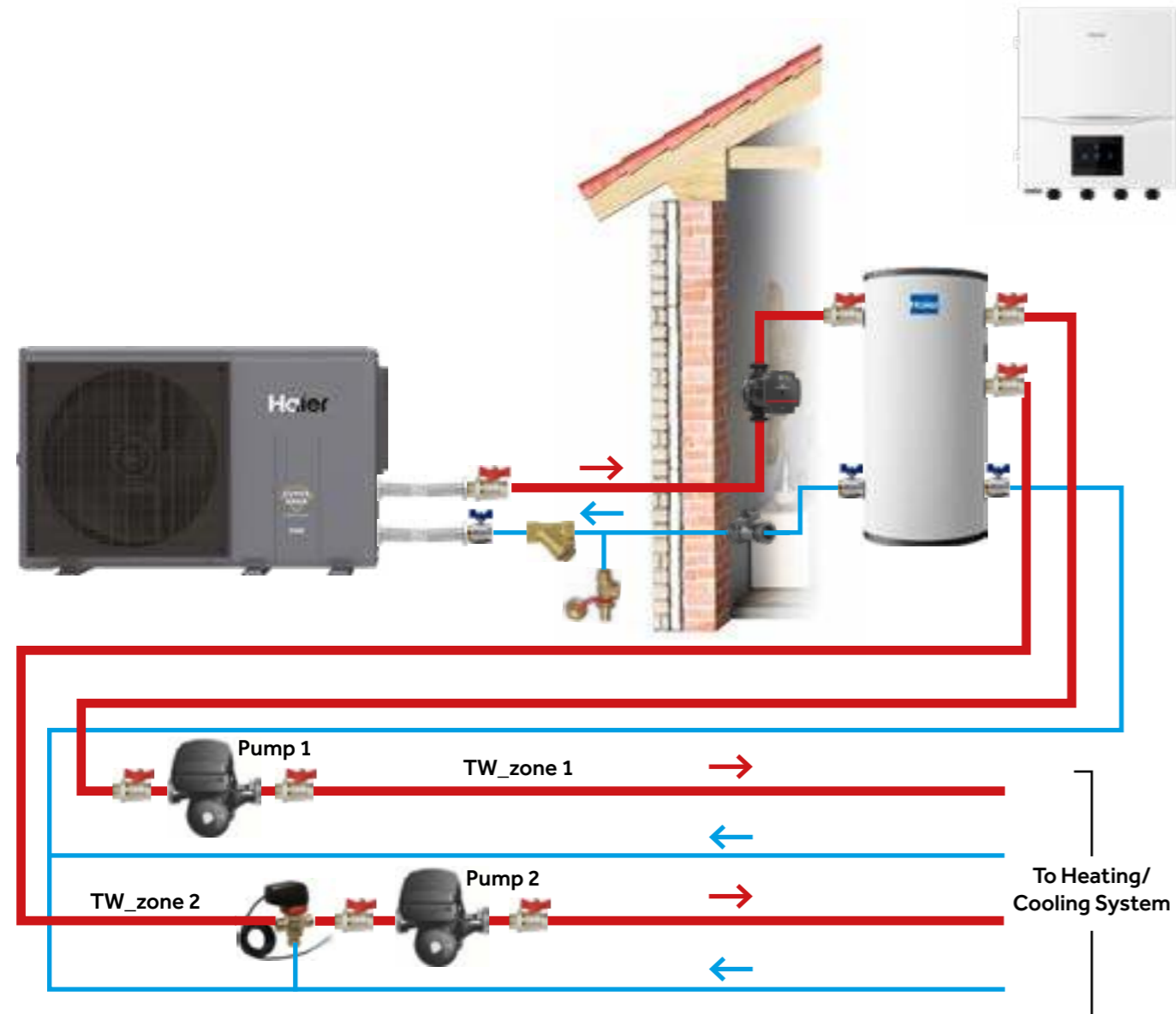

	Flexible hose pipe		Buffer Tank
	Ball Valve		Water pump
	Ball Valve		Mixing Valve
	Water filter		Delivery water flow
	Drain Valve		Return water flow

ALL THE DIAGRAMS AND THE ACCESSORIES ARE ONLY AN EXAMPLE OF THE INSTALLATION AND HAVE TO BE CARRIED OUT IN ACCORDANCE WITH LOCAL REGULATIONS.

FOR ELECTRICAL CONNECTIONS REFER TO POINT 1.0.

PUMPS 1, 2 ETC ARE CONTROLLED BY EXTERNAL RUN SIGNALS. THE HEAT PUMP HEATS THE BUFFER. THE CONTROL OF VALVES AND PUMPS AFTER THE BUFFER IS BY EXTERNAL THERMOSTATS - RUN SIGNALS.

3.2. WATER TEMPERATURE SENSOR FOR ZONE 2

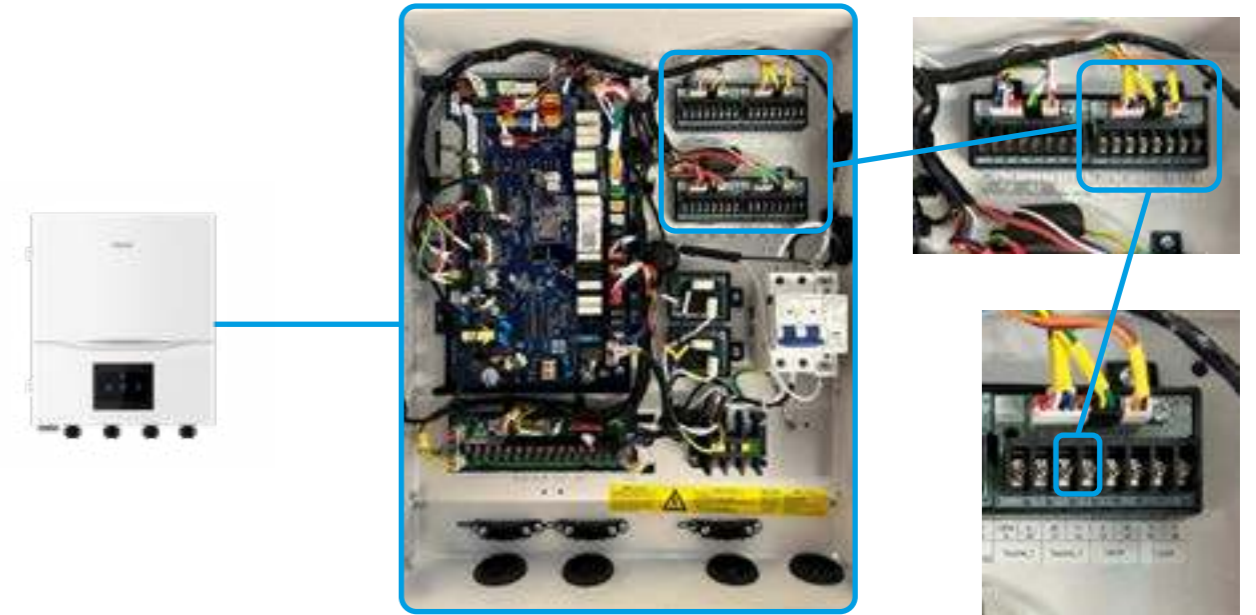

Connection Board 2

Connection Board

9	10	11	12	13	14	15	16
GND	L	M	H	A	B	X	Y
TW_zone_1		TW_zone_2		STOP		T_out2	

On the connection board number 2 between terminals 11 (M) and 12 (H) we can connect the water temperature sensor for zone 2. Sensor Zone 1 connects to 9GND and 10L

Water pump for Zone 2

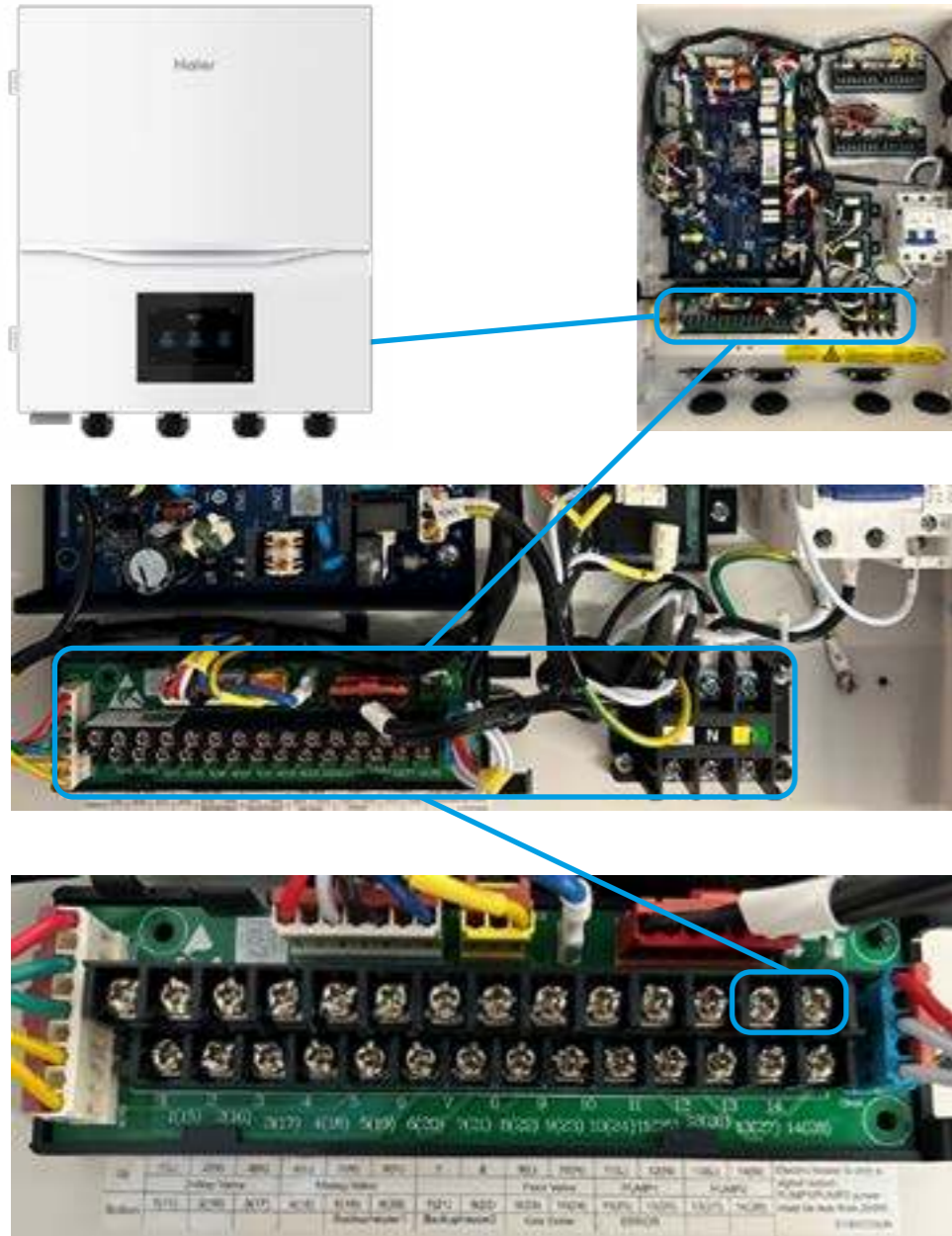

Connection Board 5

* All the connections on connection board 5 are with screw terminals.

1	2	3	4	5	6	7	8	9	10	11	12	13	14
L	N	K	L	N	K	L	N	L	N	L	N	L	N
3-Way Valve			Mixing valve				Floor Valve		Pump 1		Pump 2		
1(15)	2(16)	3(17)	4(18)	5(19)	6(20)	7(21)	8(22)	9(23)	10(24)	11(25)	12(26)	13(27)	14(28)
				L	N	L	N						
				Heater 1		Heater 2		Boiler		Error			

On connection board number 5 between terminals 13 (live) and 14 (neutral) we can connect the water pump for zone 1. On this connection we have an output voltage of 230VAC. The maximum electrical power that this contact can support is 200W.



Mixing Valve for Zone 2

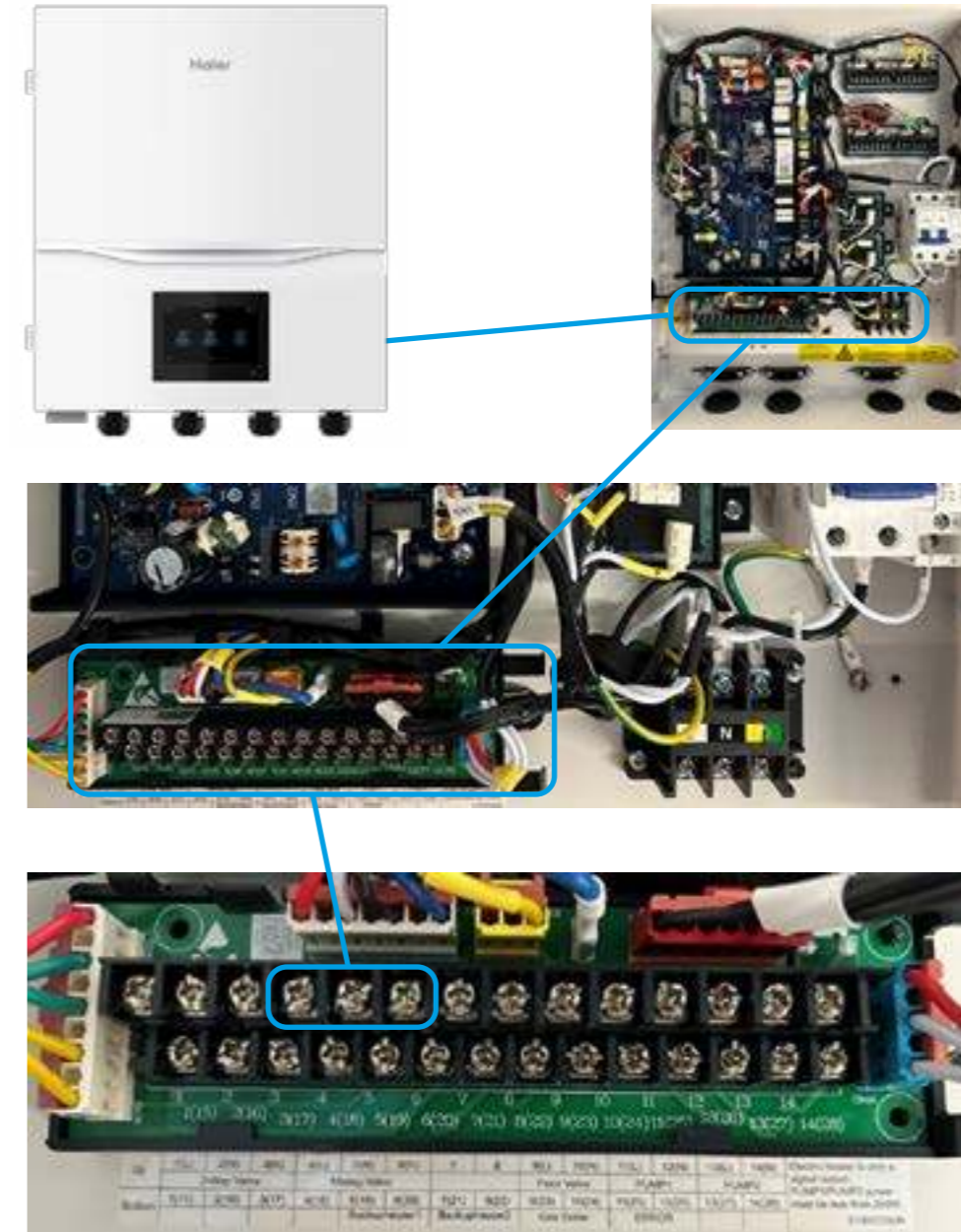

Connection Board 5

* All the connections on connection board 5 are with screw terminals.

1	2	3	4	5	6	7	8	9	10	11	12	13	14
L	N	K	L	N	K	L	N	L	N	L	N	L	N
3-Way Valve			Mixing valve			Floor Valve		Pump 1		Pump 2			
1(15)	2(16)	3(17)	4(18)	5(19)	6(20)	7(21)	8(22)	9(23)	10(24)	11(25)	12(26)	13(27)	14(28)
				L	N	L	N						
				Heater 1		Heater 2		Boiler		Error			

On connection board number 5 between terminals 4 (L), 5 (N) and 6 (K) we can connect the mixing valve for zone 2. On this connection we have an output voltage of 230VAC between 4 (L – live) and 5 (N – neutral) for closing the valve; 230VAC between 6 (K – live) and 5 (N – neutral) for opening the valve



3.3. SIMPLIFIED CONNECTION DIAGRAM

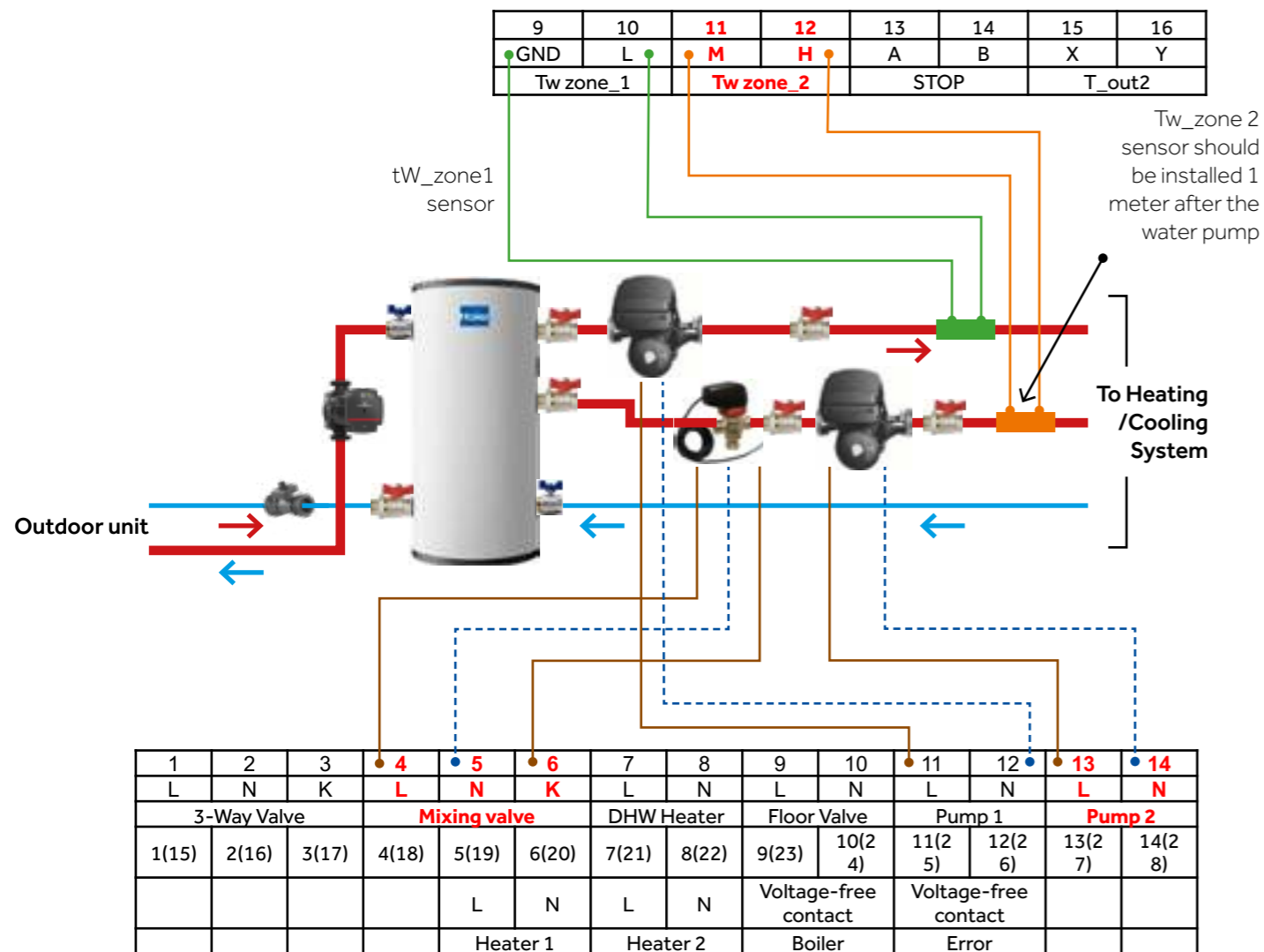

	Buffer Tank		Tw zone 2 water temp sensor
	Ball Valve		Delivery water flow
	Ball Valve		Return water flow
	Water pump		Live
	Mixing Valve		Neutral

3.4. CONTROLLER SETTINGS

Equipment Installation main settings



* SELECT THE CONTROL MODE FOR ZONE 1
* SELECT THE CONTROL MODE FOR ZONE 2

Function	Parameter Range	Settings
Zone 1	ON/OFF	ON
Zone 2	ON/OFF	ON

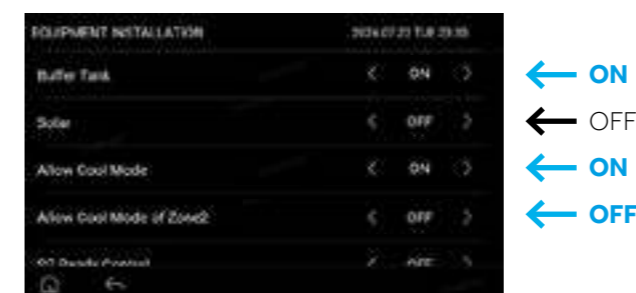

* SELECT ON TO CONSIDER BUFFER TANK
* SELECT ON TO ALLOW COOL MODE
* SELECT ON TO ALLOW COOL MODE OF ZONE 2

Function	Parameter Range	Settings
Buffer Tank	ON/OFF	ON
Allow Cool Mode	ON/OFF	ON
Allow Cool Mode Zone 2	ON/OFF	OFF

* THE PARAMETERS THAT NEED TO BE MODIFIED ARE MARKED IN BLUE.

System Installation main settings



1

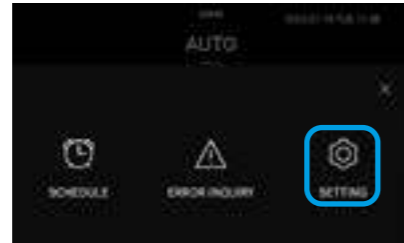

2



3

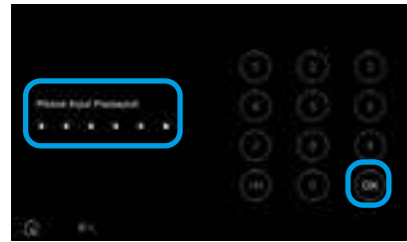

4 * Password "841226" OK



5



← Main Controller * SELECT THE CONTROL MODE FOR ZONE 1
 ← Main Controller * SELECT THE CONTROL MODE FOR ZONE 2
 ← Main Controller
 ← Main Controller

Function	Parameter Range	Settings
Control Mode of Zone 1	Main controller Third party controller, IDU ambient Temp. sensor	Main controller
Control Mode of Zone 2	Main controller Third party controller	Main controller



← 5°C
 ← 45°C
 ← 24°C
 ← 60s

*ENTER DWH TEMPERATURE



← 60s

Function	Parameter Range	Settings
Travel Time of Mixing Value	30 - 240s	60s

* THE PARAMETERS THAT NEED TO BE MODIFIED ARE MARKED IN BLUE.



← 45°C
 ← 27°C
 ← 6°C
 ← 0°C

*ENTER DELTA T° OF HEATING ON

Press "house" to return to main menu

Function	Parameter Range	Settings
ΔT for Heating On	0 - 15°C	6°C

SCROLL DOWN TWO PAGES FOR THESE SETTINGS

4.0. DOMESTIC HOT WATER

The Haier heat pump can be used as a hot water-only system. However, if you also want to use it for heating, please add this section to the schematics in Chapters 1 and 2.

4.1. DHW INSTALLATION

The Haier heat pump can be used as a hot water-only system. However, if you also want to use it for heating, please add this section to the schematics in Chapters 1 and 2.

4.1.1. SIMPLIFIED HYDRAULIC DIAGRAM

Heating and hot water system

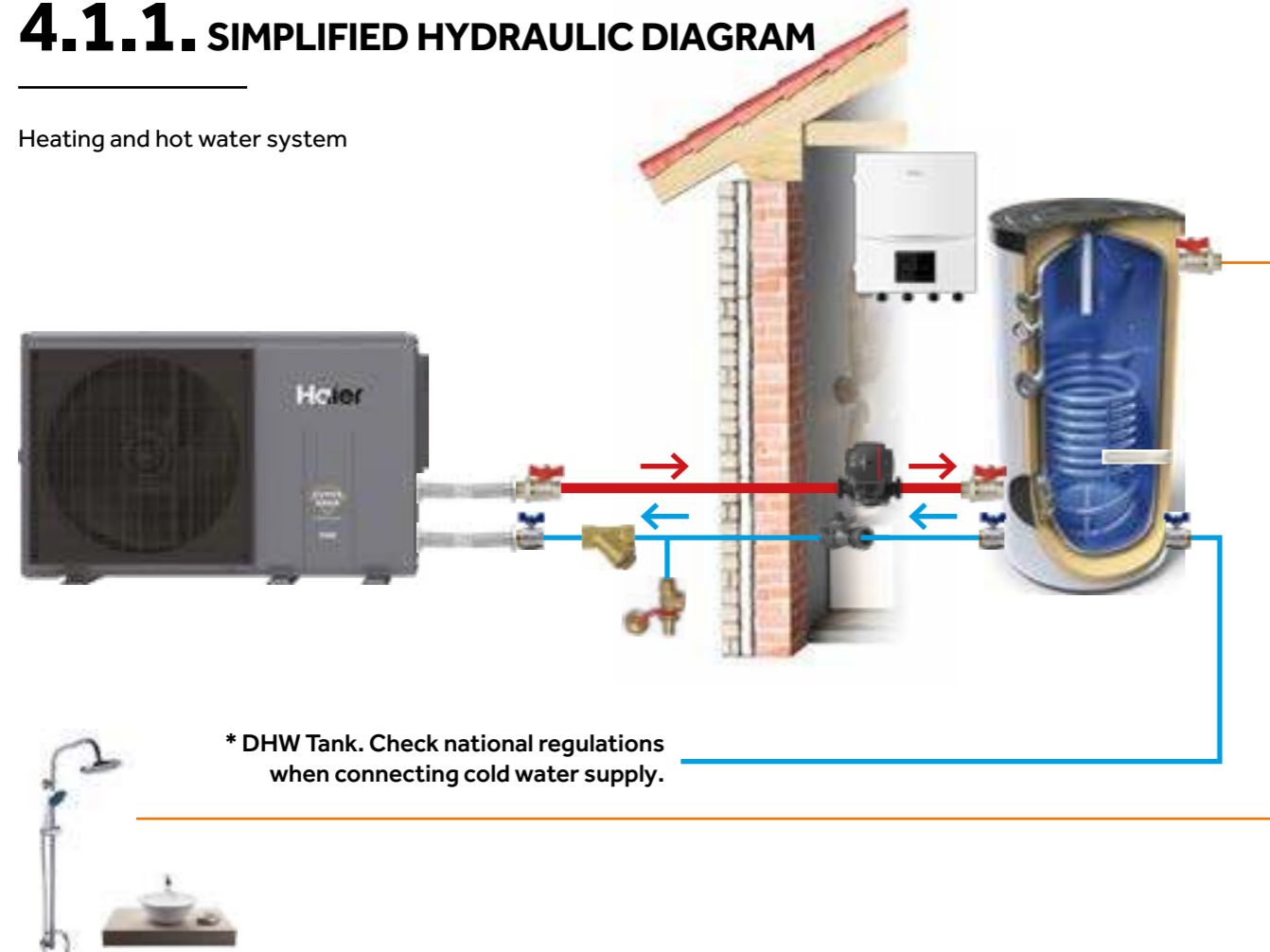

	Flexible hose pipe		DHW Tank
	Ball Valve		Electrical Heater DHW
	Ball Valve		Delivery water flow
	Water filter		Return water flow
	Drain Valve		

ALL THE DIAGRAMS AND THE ACCESSORIES ARE ONLY AN EXAMPLE OF THE INSTALLATION AND HAVE TO BE CARRIED OUT IN ACCORDANCE WITH LOCAL REGULATIONS.

FOR ELECTRICAL CONNECTIONS REFER TO POINT 1.0.

An E10 error shows if a cylinder sensor is not wired into the system.

4.1.2. CONNECTIONS

Water temperature sensors connection

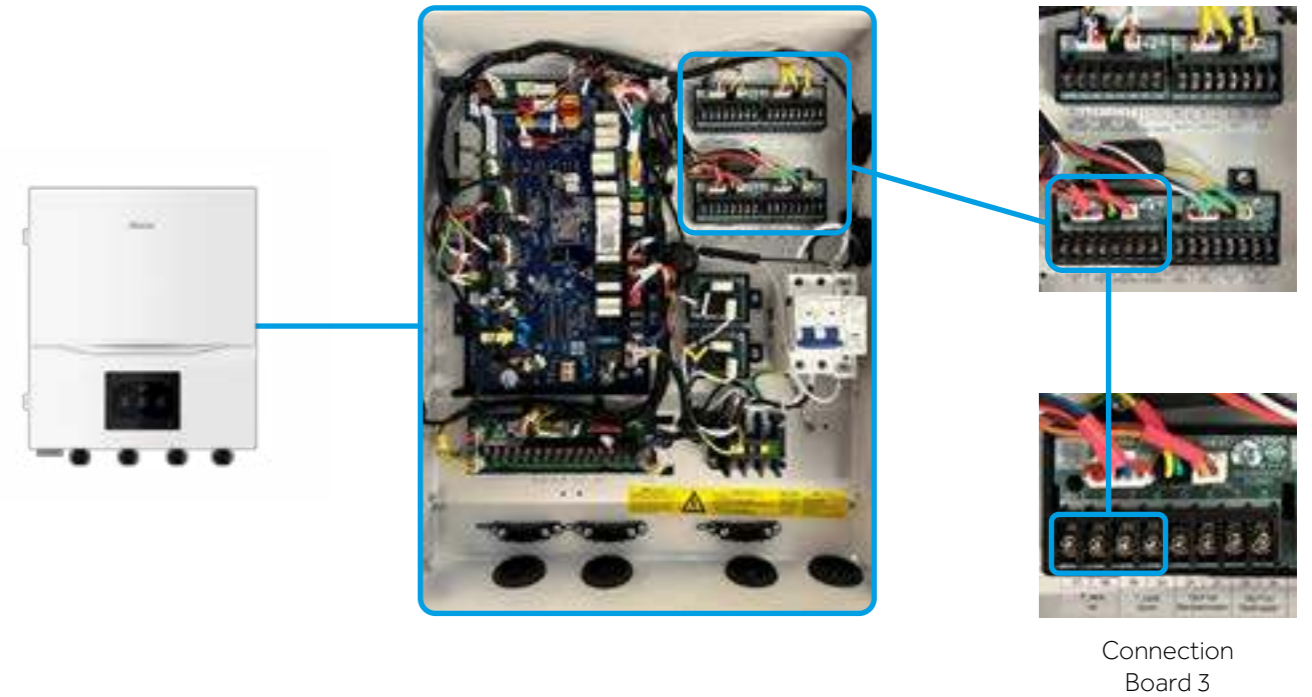

Connection Board

17	18	19	20	21	22	23	24
GND	L	M	H	A		X	Y
T_tank up		T_tank down		OLP Auxiliary Heater		OLP For Tank Heater	

On connection board number 3 between terminals 17 (GND) and 18 (L) we must connect the T_tank up water temperature sensor for the DHW tank, that should be installed in the top of the tank.

On the connection board number 3 between terminals 19 (M) and 20 (H) we must connect the T_tank down water temperature sensor for the DHW tank, that should be installed in the bottom of the tank.

* If the DHW has only one pocket for water temperature control only use T-tank up, it's necessary to modify switch BM2 on ATW-A03 N for avoid a error E10, missing temperature sensor.

Electrical Heater

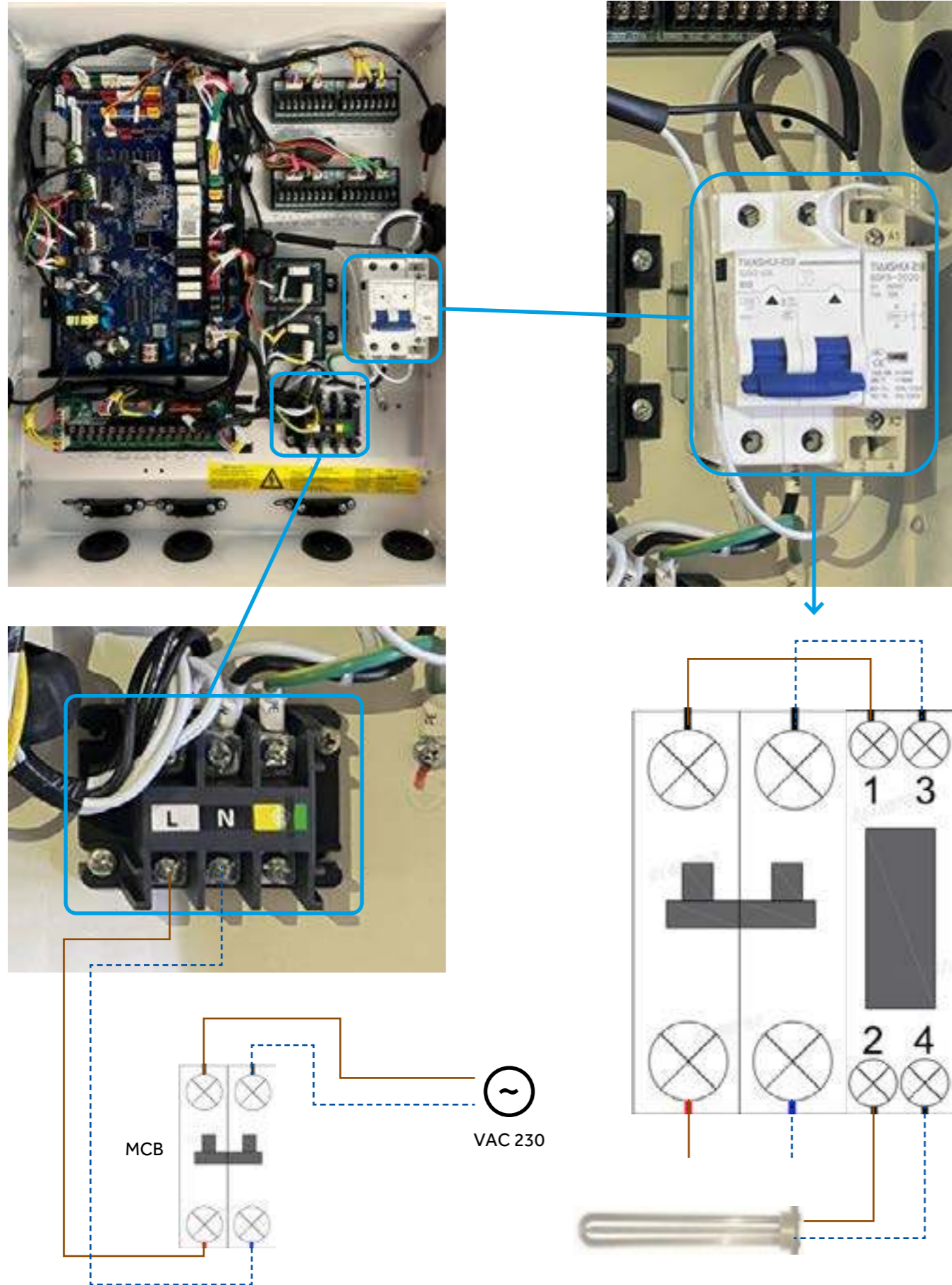

4.1.3. SIMPLIFIED CONNECTION DIAGRAM

Equipment Installation main settings

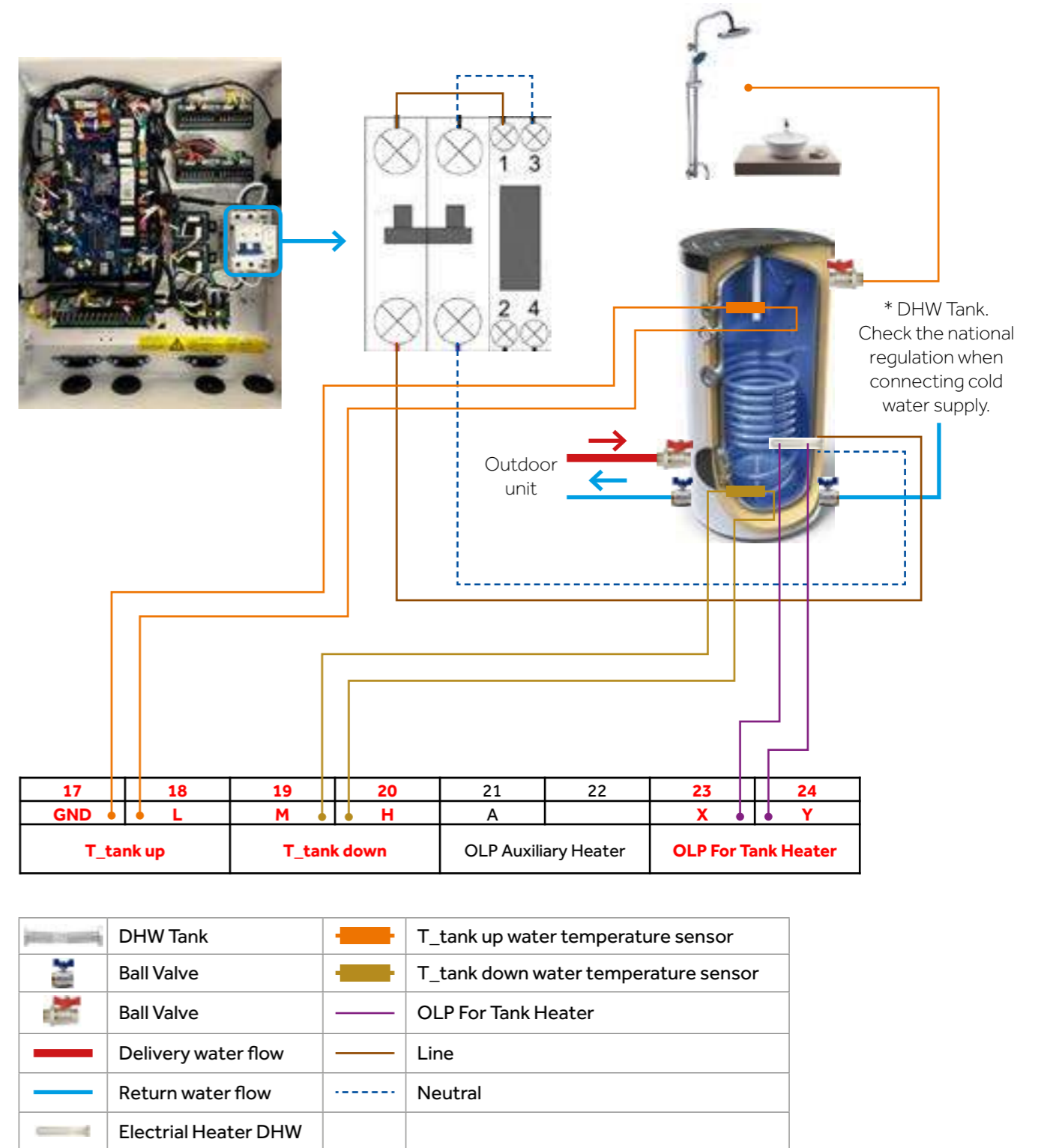

4.2.1. SIMPLIFY HYDRAULIC DIAGRAM

Heating and hot water system

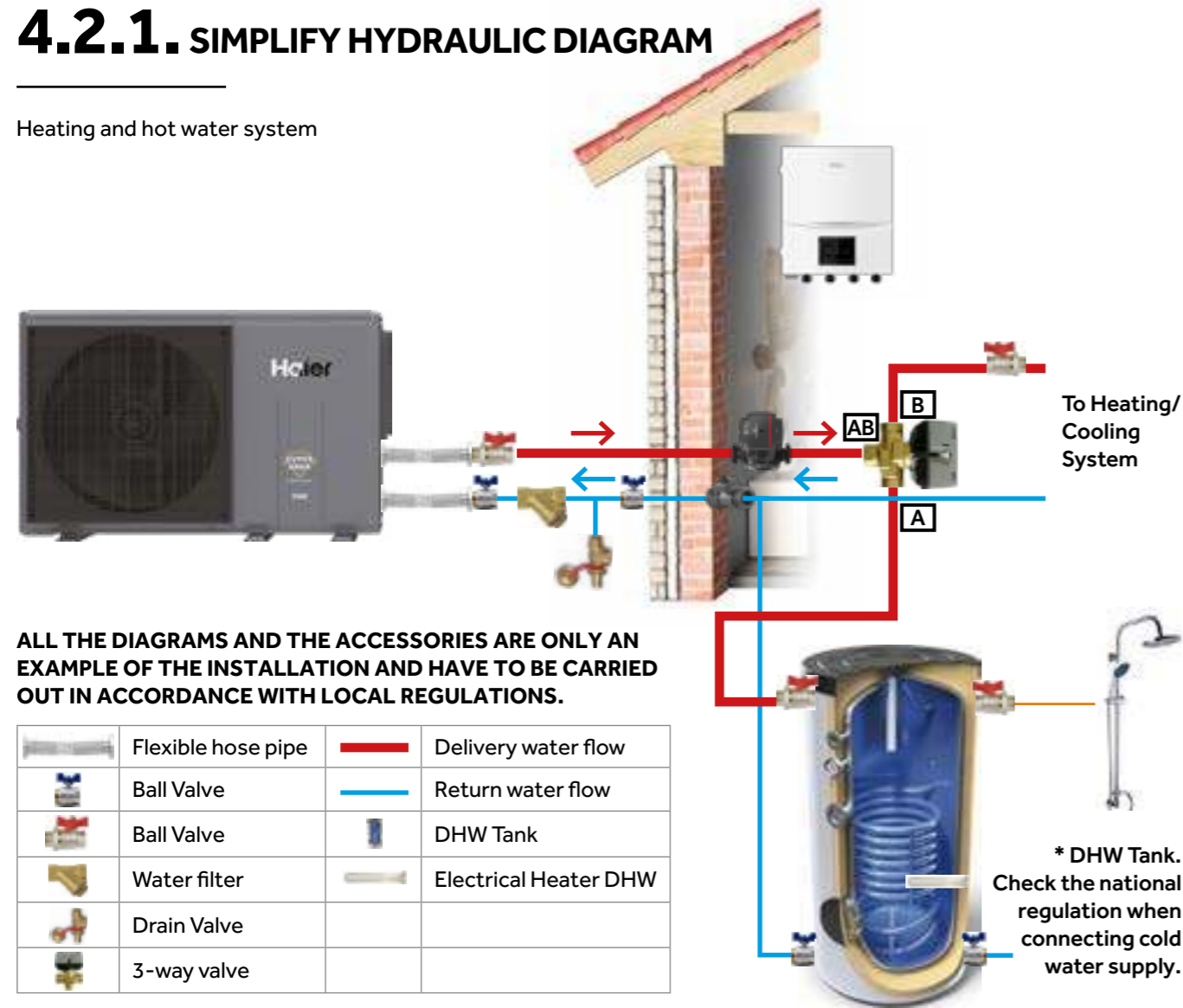

FOR ELECTRICAL CONNECTIONS REFER TO POINT 1.0.

Three-way valve

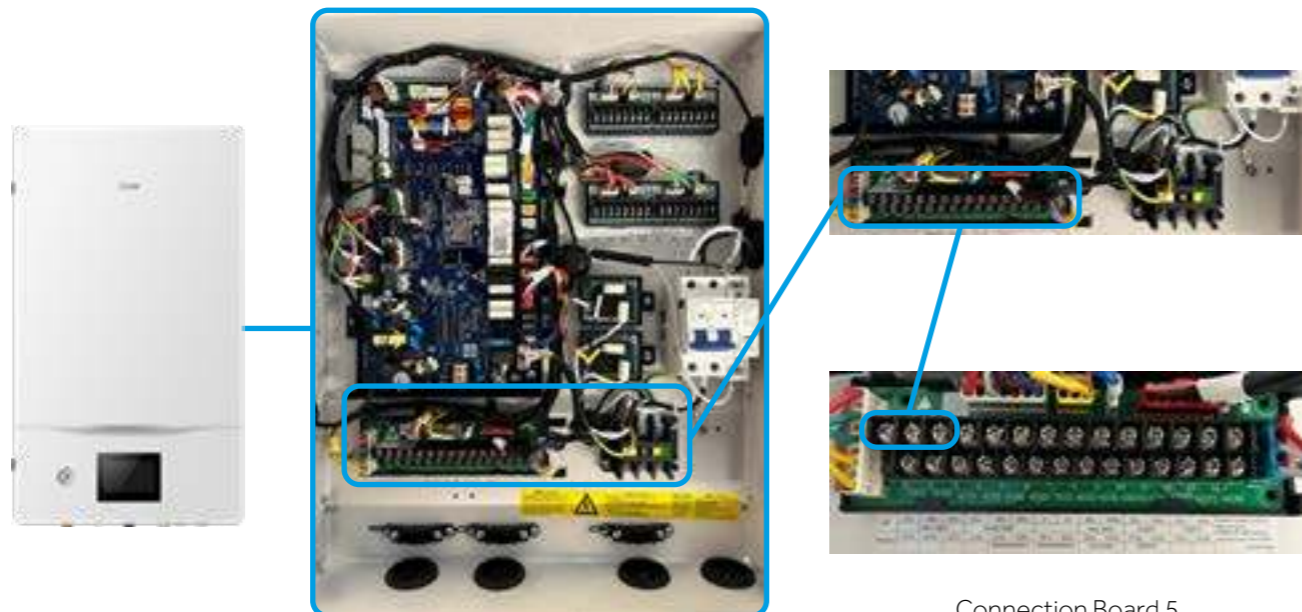

Connection Board 5

Connection Board

1	2	3	4	5	6	7	8	9	10	11	12	13	14
L	N	K	L	N	K	L	N	L	N	L	N	L	N
3-Way Valve			Mixing valve				Floor Valve		Pump 1		Pump 2		
1(15)	2(16)	3(17)	4(18)	5(19)	6(20)	7(21)	8(22)	9(23)	10(24)	11(25)	12(26)	13(27)	14(28)
				L	N	L	N	L	N	Voltage-free contact			
			Heater 1		Heater 2		Boiler		Error				

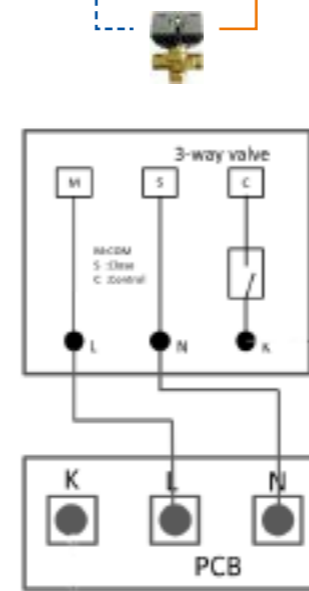

SPST

If you are using a 3-way valve with a spring return.

The valve needs a 230 Volt signal from K (live) to N (Neutral) to move the valve to DHW mode. When there is no DHW demand, there will be no power to the valve so it will return to heating using the return spring.

1	2	3	4	5	6	7	8	9	10	11	12	13	14
L	N	K	L	N	K	L	N	L	N	L	N	L	N
3-Way Valve			Mixing valve				Floor Valve		Pump 1		Pump 2		
1(15)	2(16)	3(17)	4(18)	5(19)	6(20)	7(21)	8(22)	9(23)	10(24)	11(25)	12(26)	13(27)	14(28)
				L	N	L	N	L	N	Voltage-free contact			
			Heater 1		Heater 2		Boiler		Error				

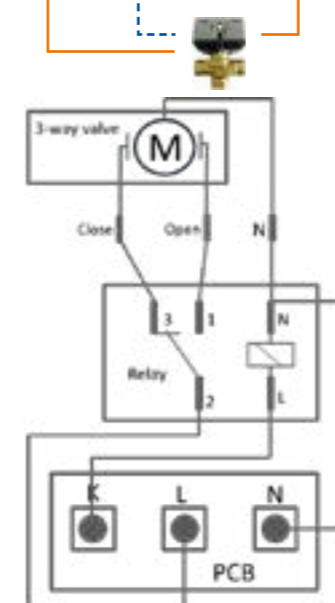

SPDT

If you are using a 3-port valve with no spring return, you will need to add a field supplied relay. The pcb only has one output so it cannot open and close the valve.

Use the L and N from the pcb to operate the relay coil and wire the valve to the relay, as per the diagram.

4.2.2. SIMPLIFIED CONNECTION DIAGRAM

Connection Board

1	2	3	4	5	6	7	8	9	10	11	12	13	14
L	N	K	L	N	K	L	N	L	N	L	N	L	N
3-Way Valve			Mixing valve				Floor Valve		Pump 1		Pump 2		
1(15)	2(16)	3(17)	4(18)	5(19)	6(20)	7(21)	8(22)	9(23)	10(24)	11(25)	12(26)	13(27)	14(28)
			L	N	L	N	L	N	L	N	Voltage-free contact		
			Heater 1		Heater 2		Boiler		Error				

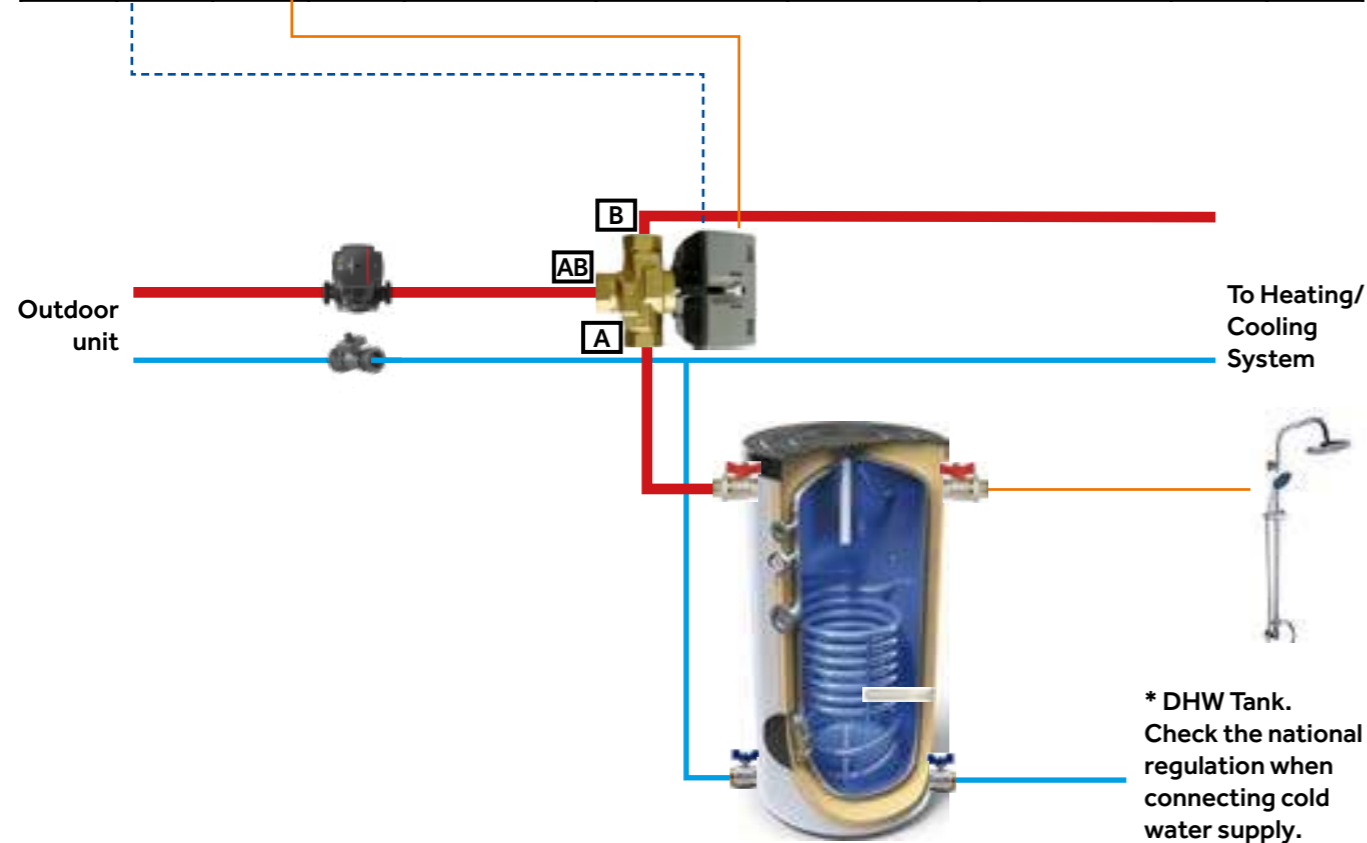

*** CONNECTIONS FOR ZONE1&2, CHECK THE CHAPTER 2.0 AND 3.0**

4.2.3. CONTROLLER SETTINGS

System Installation main settings

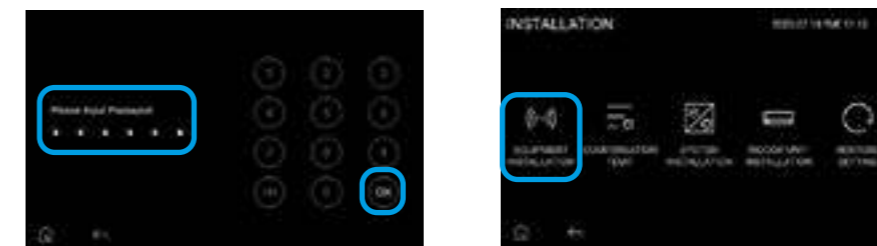

4 * Password "841226" OK



*** SELECT ON TO ACTIVATE ZONE 1**

*** SELECT ON TO CONSIDER BUFFER TANK**

Function	Parameter Range	Settings
Zone 1	ON/OFF	ON
DHW	ON/OFF	ON



*** SELECT ON TO ALLOW TANK HEATER**

Function	Parameter Range	Settings
Allow Cool Mode	ON/OFF	ON

*** THE PARAMETERS THAT NEED TO BE MODIFIED ARE MARKED IN BLUE.**



← 0°C
 ← 10min
 ← ON
 ← 3.0 kW

*** ENTER THE TANK HEATER POWER**

Press "house" to return to main menu

Function	Parameter Range	Settings
Allow Tank Heater	ON/OFF	ON
Tank Heater Power	0.0 - 9.0 kW	3.0 kW



← 45°C
 ← 27°C
 ← 6°C
 ← 0°C

*** SELECT DHW ON TEMP**

*** SELECT DELTA T° FOR HEATING ON**

THIS SETTING TELLS THE UNIT THE TEMPERATURE THE WATER MUST FALL TOO BEFORE IT STARTS HEATING THE DHW TANK.

Function	Parameter Range	Settings
DHW On Temp	30 - 75°C	45°C
ΔT for Heating On	0 - 15°C	6°C

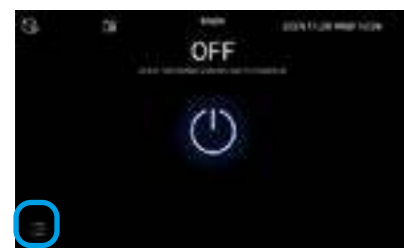

1

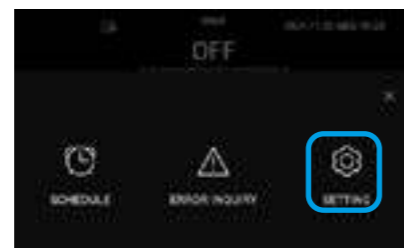

2



3

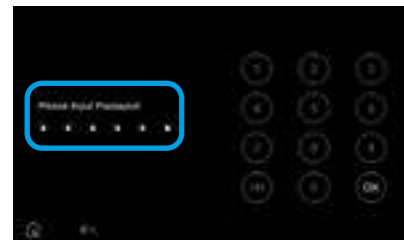

4 *** Password "841226"**



5



← 60min
 ← -3°C
 ← -1°C
 ← -3°C

*** SET TANK RE-HEAT TEMP**

Function	Parameter Range	Settings
Tank Re-heat Temp	-12 - 2°C	-3°C



← 5°C
 ← 45°C
 ← 24°C
 ← 60s

Press "house" to return to main menu

Function	Parameter Range	Settings
DT for Cooling On	0 - 15°C	5°C

*** THE PARAMETERS THAT NEED TO BE MODIFIED ARE MARKED IN BLUE.**



← Main Controller
 ← Main Controller
 ← Main Controller
 ← Main Controller

*** SELECT THE CONTROL MODE FOR ZONE 1**

*** SELECT THE CONTROL MODE OF DHW**

Function	Parameter Range	Settings
Control Mode of Zone 1	Main controller Third party controller, IDU ambient Temp. sensor	Main controller
Control Mode of DHW	Main controller Third party controller, IDU ambient Temp. sensor	Main controller

4.1.4. CONTROLLER SETTINGS

System Installation main settings



1

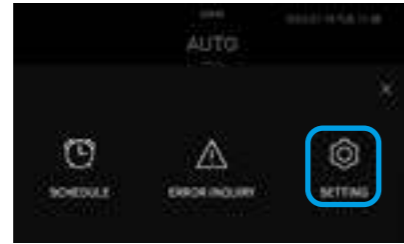

2



3

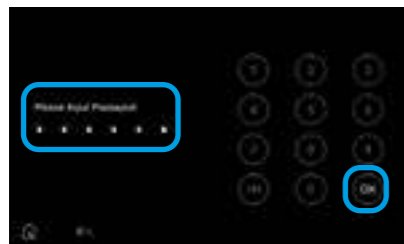

4 * Password "841226" OK



5



← OFF
← ON
← OFF

* SELECT ON FOR DHW

Function	Parameter Range	Settings
DHW	ON/OFF	ON



← 0°C
← 10min
← ON
← 3.0kW

* SELECT ON TO ALLOW TANK HEATER
* ENTER THE TANK HEATER POWER

Press "house" to return to main menu

Function	Parameter Range	Settings
Allow Tank Heater	ON/OFF	ON
Tank heater power	0.0 - 9.0 kW	3.0kW

* THE PARAMETERS THAT NEED TO BE MODIFIED ARE MARKED IN BLUE.



1

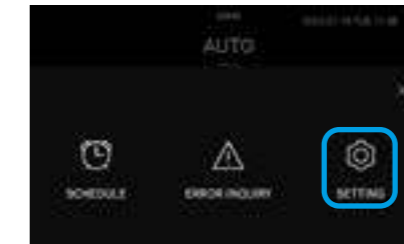

2



3

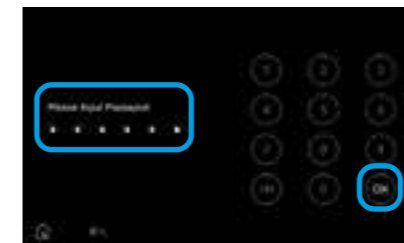

4 * Password "841226" OK



5



← Main Controller
← Main Controller
← Main Controller
← Main Controller

* SELECT THE CONTROL MODE OF DHW

Function	Parameter Range	Settings
Control Mode of DHW	Main controller, Third party controller	Main controller



← 45°C
← 27°C
← 6°C
← 0°C

* SELECT DHW ON TEMP

THIS SETTING TELLS THE UNIT THE TEMPERATURE THE WATER MUST FALL TOO BEFORE IT STARTS HEATING THE DHW TANK.

Function	Parameter Range	Settings
DHW On Temp	30 - 75°C	45°C

5.0. AUXILIARY HEAT SOURCE CONNECTION

This chapter focuses on systems that require additional heaters and boilers to support the heat pumps in severe weather conditions.

5.1. ELECTRICAL HEATER

This chapter explains how to install backup electric heaters within the all-in-one system.

5.1.1. SIMPLIFIED HYDRAULIC DIAGRAM

5.1.1.1. Without Buffer Tank

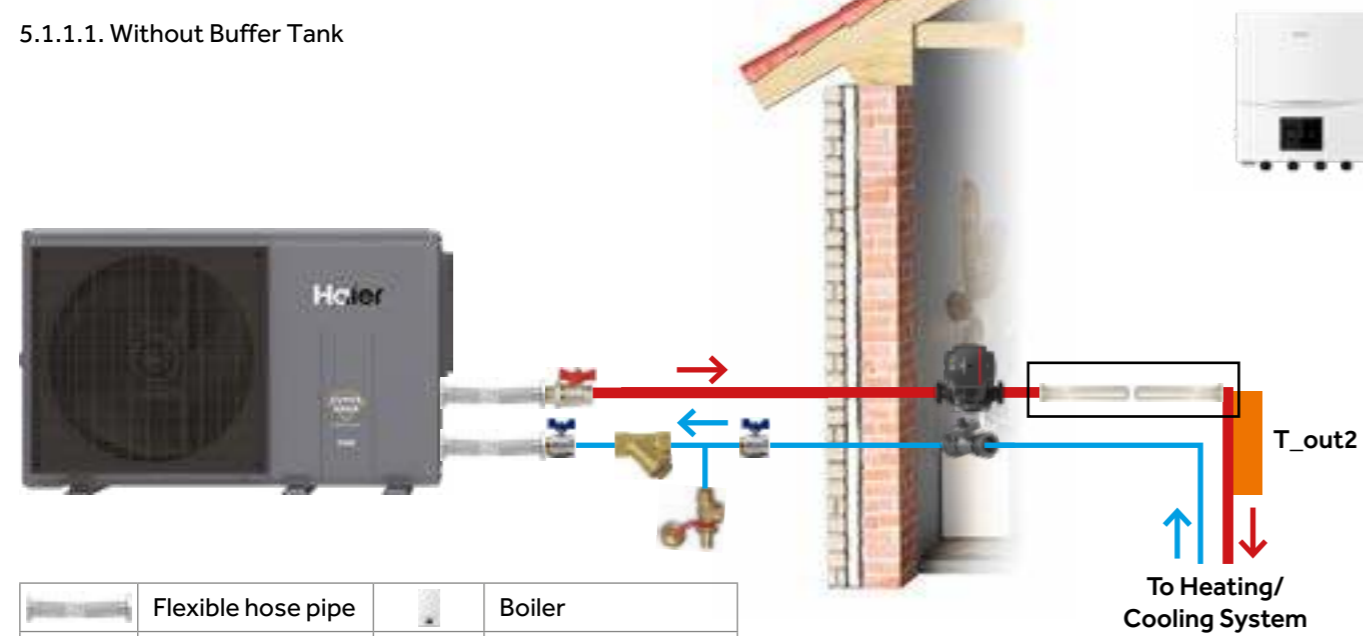

ALL THE DIAGRAMS AND THE ACCESSORIES ARE ONLY AN EXAMPLE OF THE INSTALLATION AND HAVE TO BE CARRIED OUT IN ACCORDANCE WITH LOCAL REGULATIONS.

FOR ELECTRICAL CONNECTIONS REFER TO POINT 1.0.

5.1.1.2. With Buffer Tank

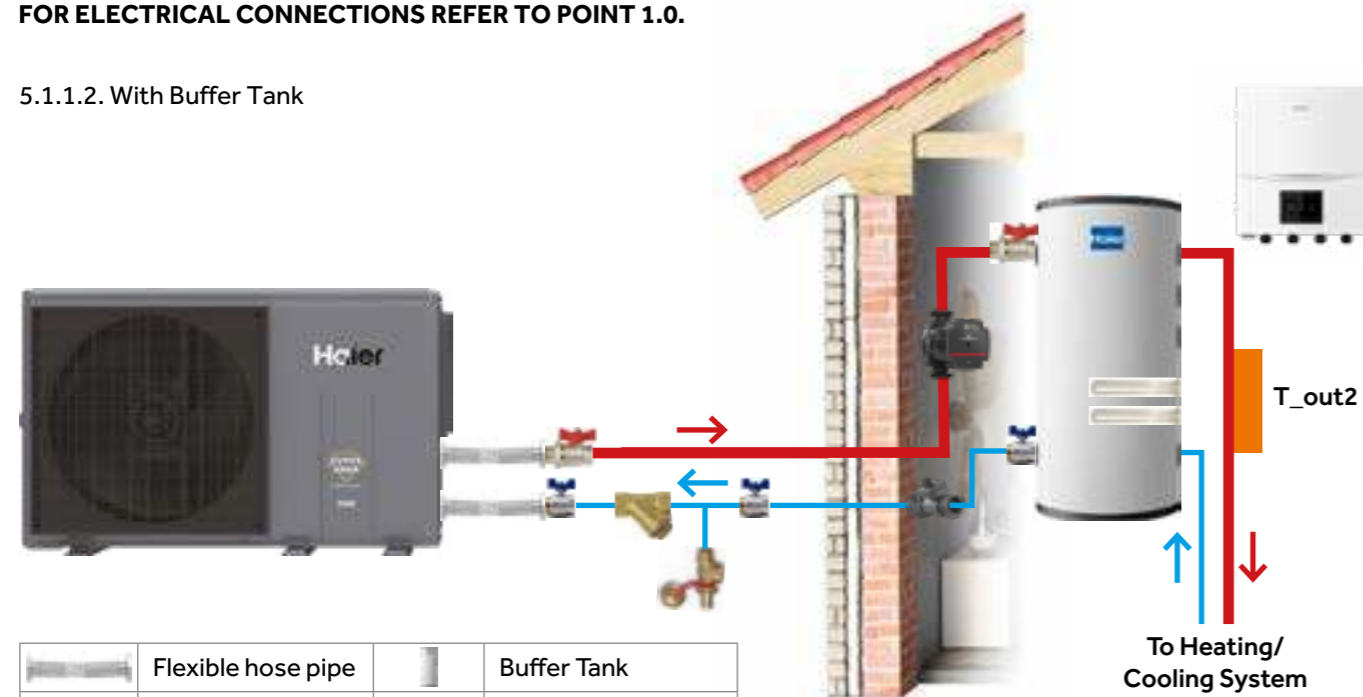

5.1.2. CONNECTIONS

Temperature sensor for Auxiliary Heat Source

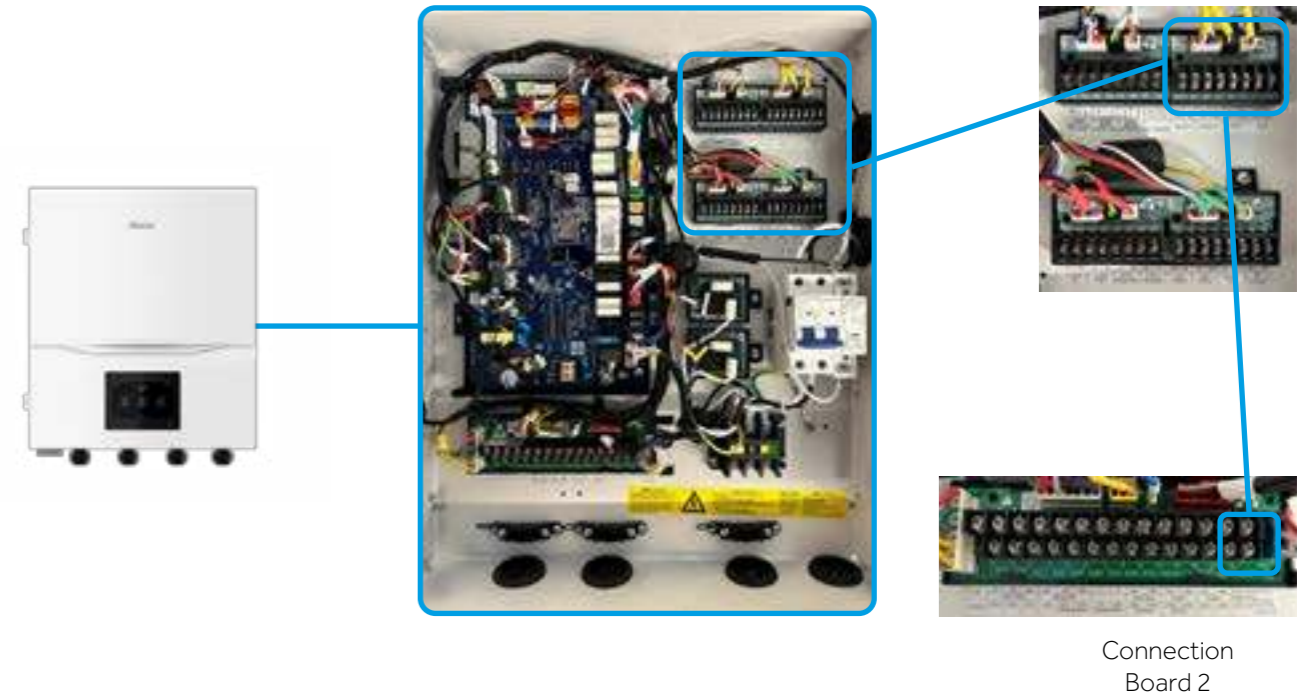

Connection Board

9	10	11	12	13	14	15	16
GND	L	M	H	A		X	Y
Tw zone_1		Tw zone_2		STOP		T_out2	

On connection board number 2 between terminals 15 (X) and 16 (Y) we can connect the water temperature sensor for T_out2.

*If we activate the backup heater, it's mandatory to connect the T_out2 sensor after auxiliary heat source.

An E02 error occurs if T_out 2 is not connected.

5.1.2. CONNECTIONS

Protection of electrical heater for Auxiliary Heat Source

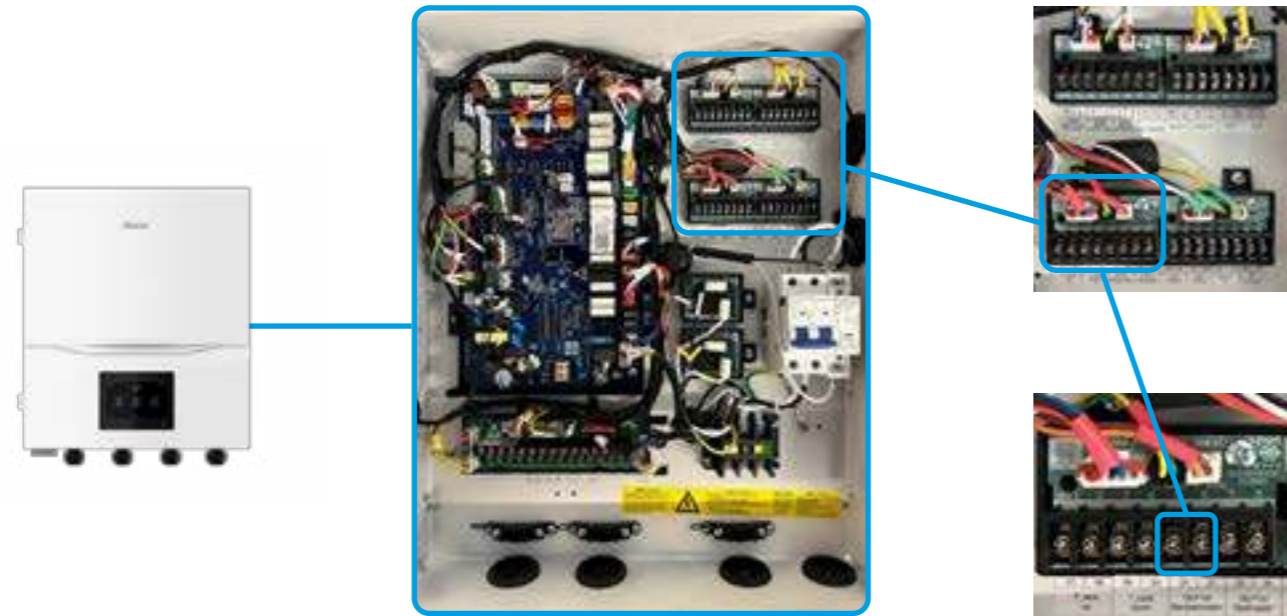

Connection Board 3

Connection Board

17	18	19	20	21	22	23	24
GND	L	M	H	A	B	X	Y
T_tank up		T_tank down		OLP Auxiliary Heater		OLP For Tank Heater	

On connection board number 3, between terminals 21 (A) and 22 (B), connect the electric heater protection for the auxiliary heat source. This is a digital input signal, normally closed, volt free contact, i.e. if the contact is closed, there is no fault; if the contact is open, there is a fault.

If the back up heater has its own OLP inside you can use a jumper here.

Control signal for Auxiliary Heat Source

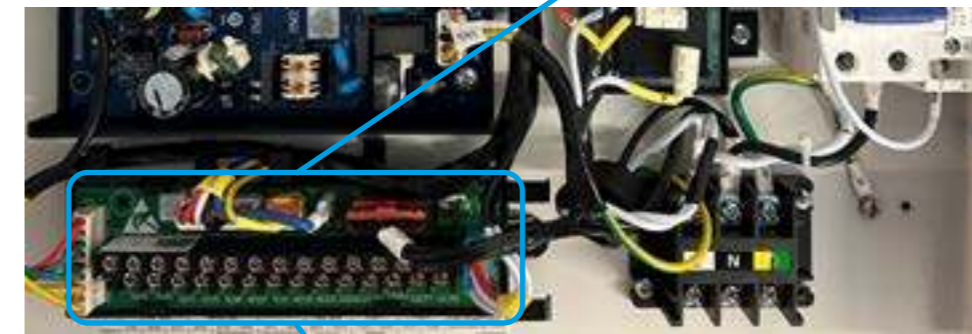

Connection Board 5

1	2	3	4	5	6	7	8	9	10	11	12	13	14
L	N	K	L	N	K	L	N	L	N	L	N	L	N
3-Way Valve			Mixing valve				Floor Valve		Pump 1		Pump 2		
1(15)	2(16)	3(17)	4(18)	5(19)	6(20)	7(21)	8(22)	9(23)	10(24)	11(25)	12(26)	13(27)	14(28)
				L	N	L	N						
				Heater 1		Heater 2		Boiler		Error			

On connection board number 5, between terminals 5(19) and 6(20) we can connect the signal for the relay for heater 1 and between terminals 5(19) and 6(20) we can connect the signal for the relay for heater 2. Both of these connections have an output voltage of 230VAC to activate a relay.

*This connection must be done through a relay.

5.1.3. SIMPLIFIED CONNECTION DIAGRAM

5.1.3.1. Without Buffer Tank

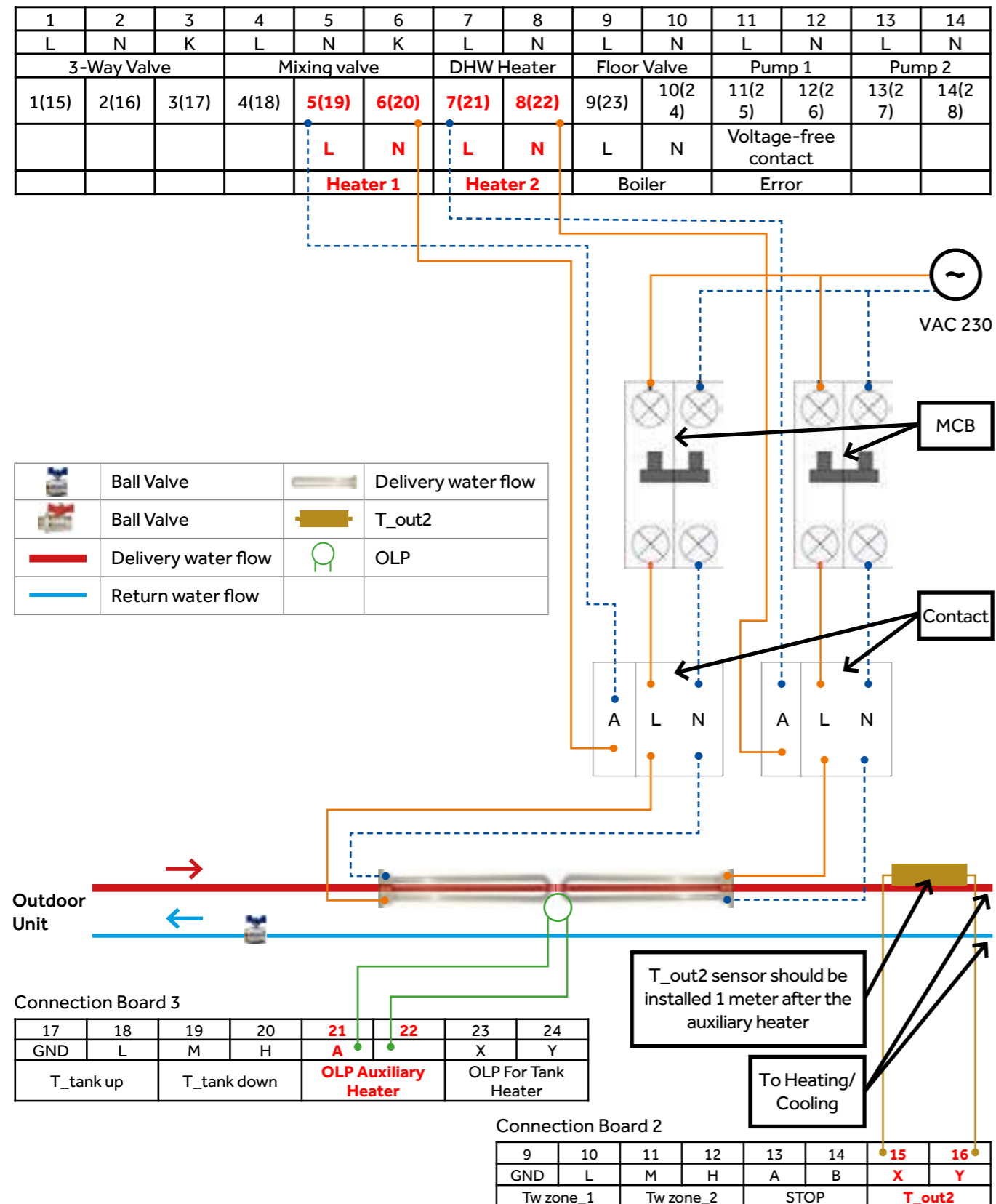

5.1.3. WITH BUFFER TANK

5.1.3.2. With Buffer Tank

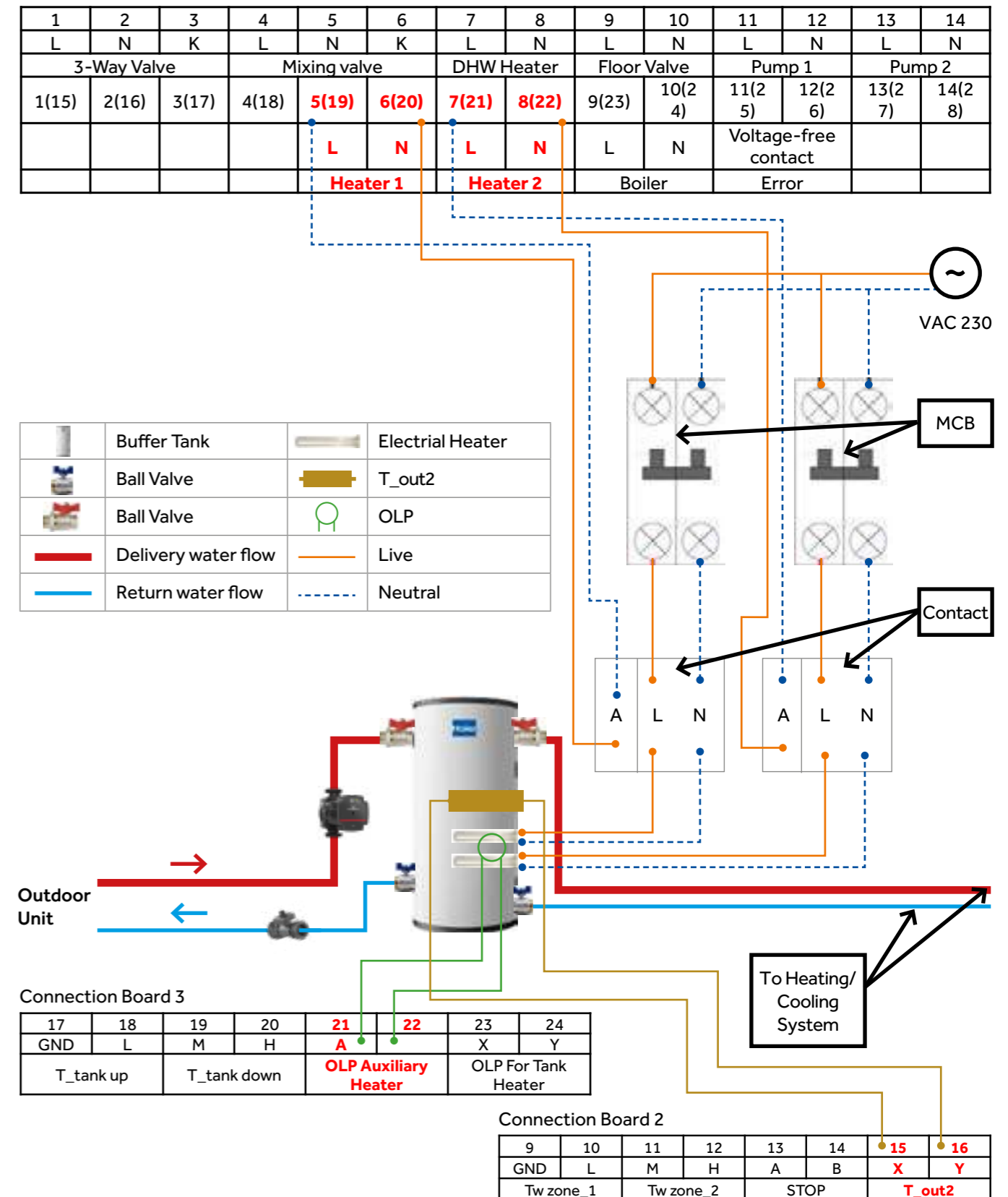

5.1.4. CONTROLLER SETTINGS

Equipment Installation main settings

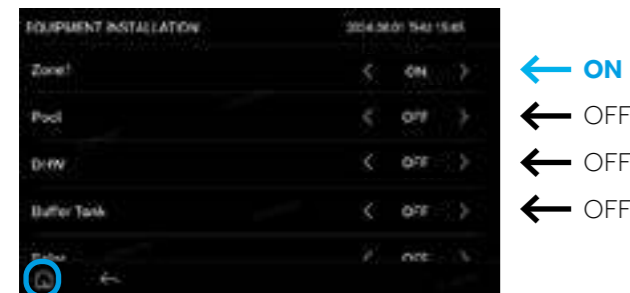
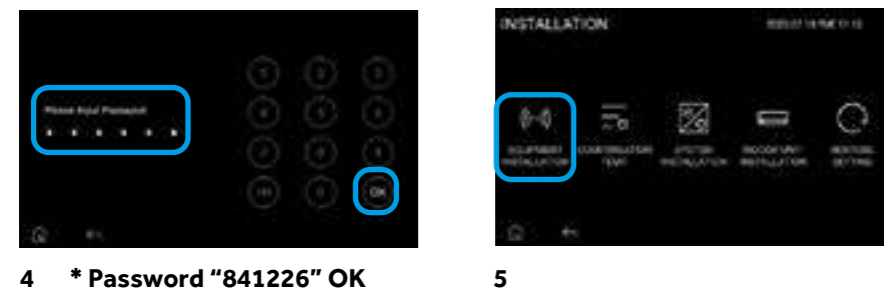
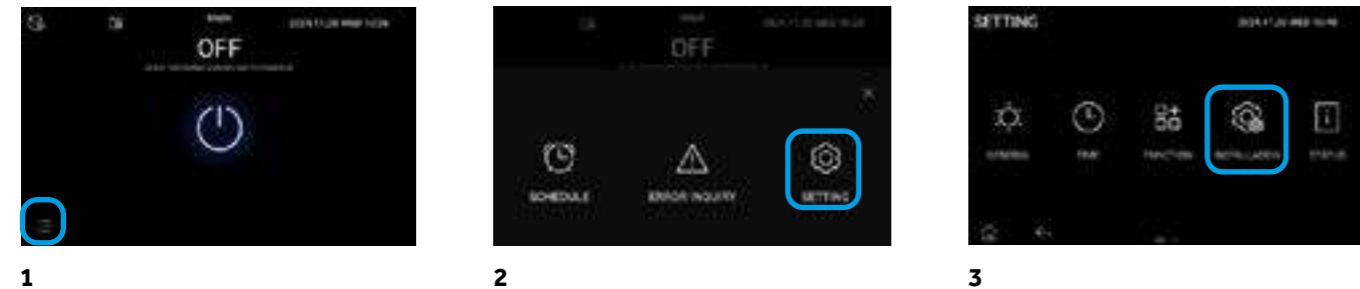

- ← ON
- ← OFF
- ← OFF
- ← OFF

*** SELECT ON TO ACTIVATE ZONE 1**

Press "house" to return to main menu

Function	Parameter Range	Settings
Zone 1	ON/OFF	ON

*** THE PARAMETERS THAT NEED TO BE MODIFIED ARE MARKED IN BLUE.**

System Installation main settings

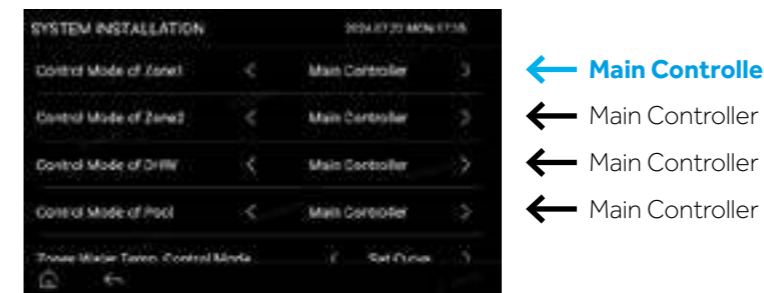
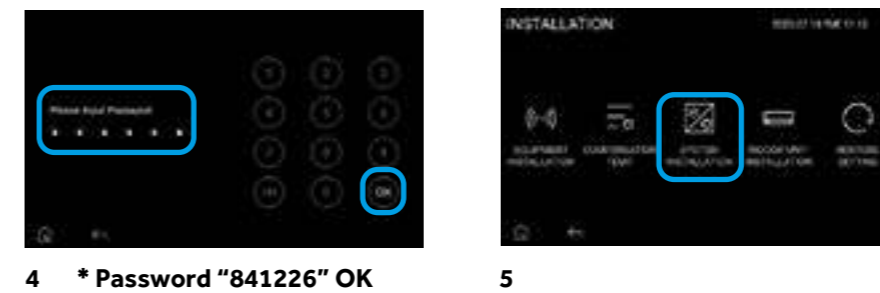

- ← Main Controller
- ← Main Controller
- ← Main Controller
- ← Main Controller

*** SELECT THE CONTROL MODE FOR ZONE 1**

Function	Parameter Range	Settings
Control Mode of Zone 1	Main controller Third party controller	Main controller



- ← Electric Heating & Boiler
- ← 15°C
- ← 10°C

*** SELECT THE AUXILIARY HEAT SOURCE**

Function	Parameter Range	Settings
Auxiliary Heat Source	Electric Heating & Boiler, Electric Heating, Boiler	Electric Heating & Boiler

*** THE PARAMETERS THAT NEED TO BE MODIFIED ARE MARKED IN BLUE.**

System Installation main settings



← 45°C
← 27°C
← 6°C
← 0°C

***SET THE AMBIENT TEMP FOR HEATING OFF**
***SET THE DT° FOR HEATING ON**

Function	Parameter Range	Settings
Ambient Temp. of Heating Off	5 - 35°C	27°C
ΔT for Heating On	0 - 15°C	6°C

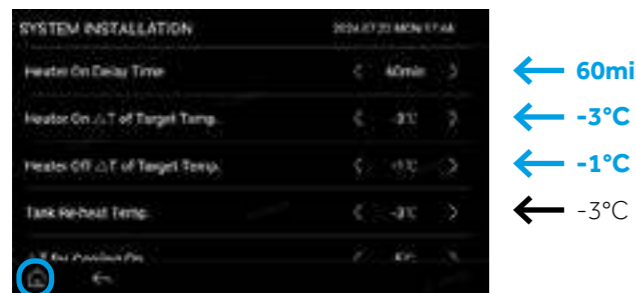

← 60min
← -3°C
← -1°C
← -3°C

***SET HEATER DELAY TIME AFTER COMPRESSOR STARTS**

Press "house" to return to main menu

Function	Parameter Range	Settings
Heater On Delay Time	0 - 120min	60min
Heater On ΔT of Target Temp	-10 - -2°C	-3°C
Heater Off ΔT of Target Temp	-8 - 0°C	-1°C

*** THE PARAMETERS THAT NEED TO BE MODIFIED ARE MARKED IN BLUE.**

Indoor Unit Installation main settings



1

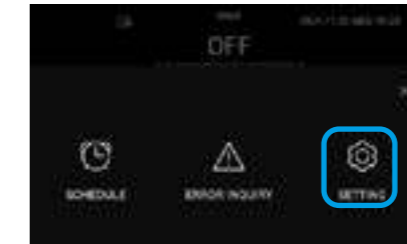

2



3

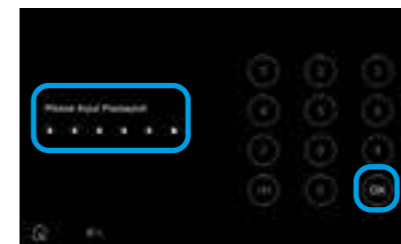

4 * Password "841226" OK



5



← Heater 1 & 2
← Normal
← OFF
← Auto

*** SELECT HEATING BY HEATER 1, 2 OR 1 AND 2**

Press "house" to return to main menu

Function	Parameter Range	Settings
Selection of IDU Electric Heater Type	None, Heater 1, Heater 2, Heater 1 & 2	Heater 1 & 2

*** THE PARAMETERS THAT NEED TO BE MODIFIED ARE MARKED IN BLUE.**

6.0. SG READY - SMART GRID SG READY

In many markets, a smart grid connection can be used to limit the maximum power drawn by the heat pump. This functionality is built into the Haier unit.

6.1. CONNECTIONS

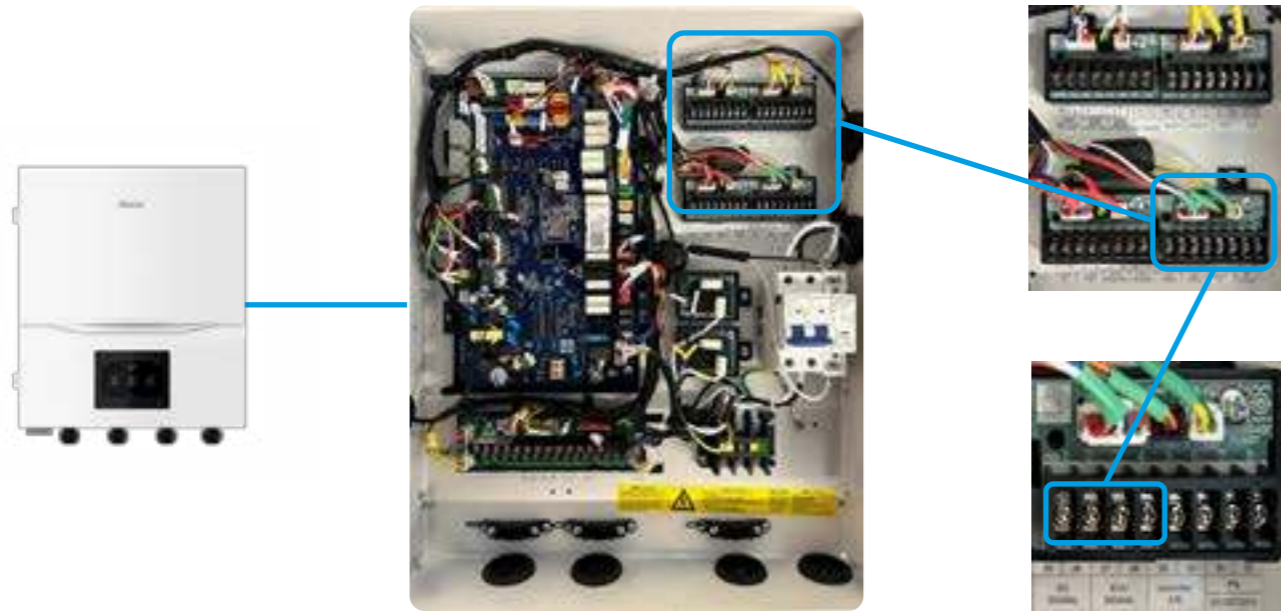

Connection Board 4

Connection Board

25	26	27	28	29	30	31	32
GND	L	M	H	A		X	Y
SG Signal		EVU Signal		Controller A/B		PQ	
SG1		SG2					

On connection board number 4 between terminals 25 (GND) and 26 (L) we have a volt-free signal for the Smart Grid signal. Also on connection board number 4 between terminals 27 (M) and 28 (H) we have a volt-free signal for the EVU signal.

Note there is a 10 second delay when SG signal is received before it shows on screen.

Logic Control

Status display on controller	Signal Input		Operation		
	SG Signal	EVU Signal	Heat	Cool	DHW
	Open	Open	Keep current operation	Keep current operation	Keep current operation
SG1	Close	Open	Heat pump not available	Cooling mode not available	Heat pump not available
SG2	Open	Close	+A°C on current setting Temp. <small>Note A: 2 to 6°C, can be set on controller, default is 4°C</small>	+D°C on current setting Temp. <small>Note: D: -2 to 6°C, can be set on controller, default is 4°C</small>	+B°C on current setting Temp. <small>Note: B: 4 to 8°C, can be set on controller, default is 4°C</small>
Sg3	Close	Close	Water temp. control, Water temp. change to Max. heating (except 3rd party control) Room temp. control, change setting temp. to 26°C	Water temp. control, Water temp. change to Min. cooling (except 3rd party control) Room temp. control, change setting temp. to 20°C	Change setting temp. to Max. DHW setting

6.2. CONTROLLER SETTINGS

Equipment Installation main settings

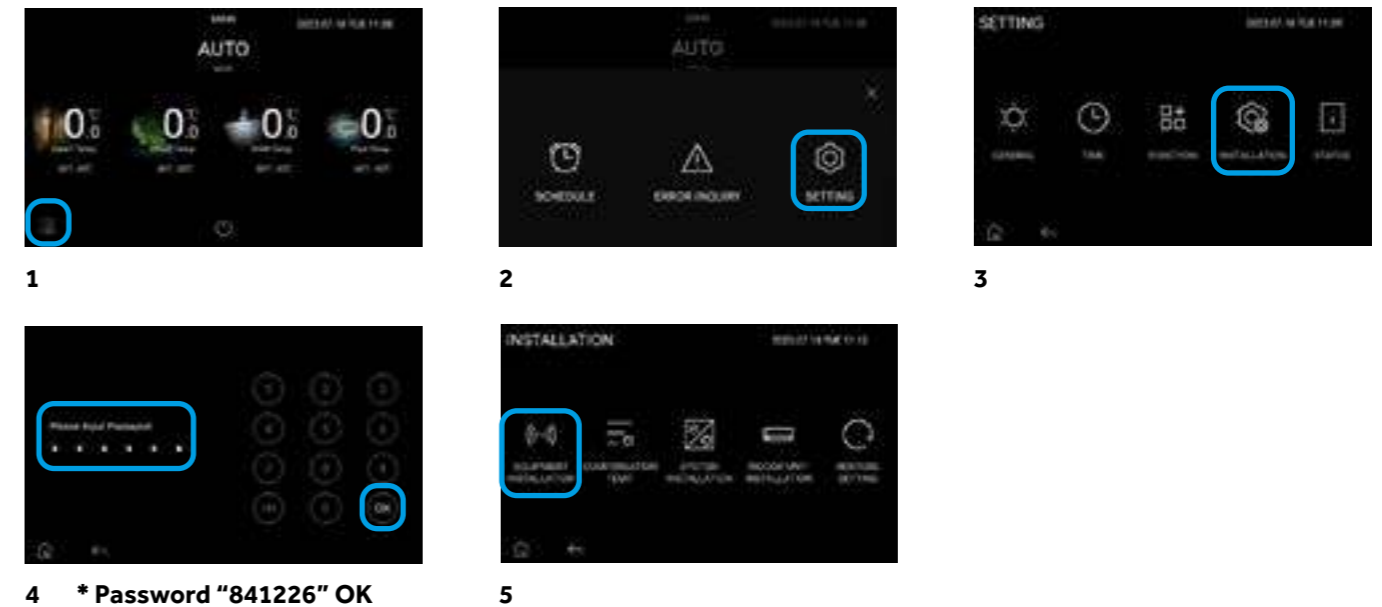

4 * Password "841226" OK



*SELECT ON TO ACTIVATE SMART GRID
SET THE TEMPERATURE YOU WANT THE UNIT TO RUN WHEN IN SMART GRID MODE HERE

Function	Parameter Range	Settings
SG Ready Control	ON/OFF	ON
SG2 compensation Temp. Of Heating	2 - 6°C	4°C
SG2 compensation Temp. Of DHW	4 - 8°C	6°C
SG2 compensation Temp. Of Cooling	-2 - -6°C	-4°C



Press "house" to return to main menu

Function	Parameter Range	Settings
SG3 heating Temp.	16 - 30°C	26°C
SG3 cooling Temp.	16 - 30°C	20°C

9.0. THIRD-PARTY CONTROLLER SWITCH SIGNAL

The Haier Super Aqua Heat Pump range can be controlled in a number of ways:

1. Using return water temperature in either a fixed or weather compensated setting when connected to a buffer.
2. Controlled to heat or cool up to 2 zones either at a fixed or weather compensated water temperature using third party room thermostats with a Volt free signal. Note this configuration is not compatible with the hOn app
3. Controlled to heat or cool up to 2 zones either at a fixed or weather compensated water temperature using Haier room thermostats which are compatible with Haier's hOn app.

9.1. THIRD-PARTY CONTROLLER SWITCH SIGNAL

The unit can be controlled in 2 ways, with a cool heat changeover switch or separate thermostats. It's possible to set it as a Type1 or Type 2.

Type 1

1	2	3	4	5	6	7	8
GND	L	M	H	A	B	X	Y
Heat requirement (ON/OFF) - ZONE1		Cool requirement (ON/OFF) - ZONE1		Heat requirement (ON/OFF) - ZONE2		Cool requirement (ON/OFF) - ZONE2	

Type 1 uses a separate thermostat for cooling and heating.

Type 1

1	2	3	4	5	6	7	8
GND	L	M	H	A	B	X	Y
Heat / Cool		Zone 1 ON/OFF		Zone 2 ON/OFF			

Type 2 uses a cool heat changeover switch.

9.1.1. TYPE 1 - MOST COMMONLY USED SYSTEM



* All the connections on connection board 1, 2, 3 and 4 are with screw terminals.



Connection Board 1

9.1.1. THIRD-PARTY CONTROLLER SWITCH SIGNAL – TYPE 1

1	2	3	4	5	6	7	8
GND	L	M	H	A	B	X	Y
Heat requirement (ON/OFF) - ZONE1		Cool requirement (ON/OFF) - ZONE1		Heat requirement (ON/OFF) - ZONE2		Cool requirement (ON/OFF) - ZONE2	

- 1) The contacts are all volt-free.
- 2) This set up is used when there are separate cooling and heating thermostats.
- 3) If you make a contact from 1-2 the unit will start in heating mode, if you make a contact from 3-4 the unit will start in cooling mode.
- 4) If you make a contact from 5-6 the unit will start in heating mode zone 2, If you make a contact from 7-8 the unit will start in cooling mode zone 2.
- 5) You must not send a cooling and heating run signal at the same time.

Simplified Connection Diagram

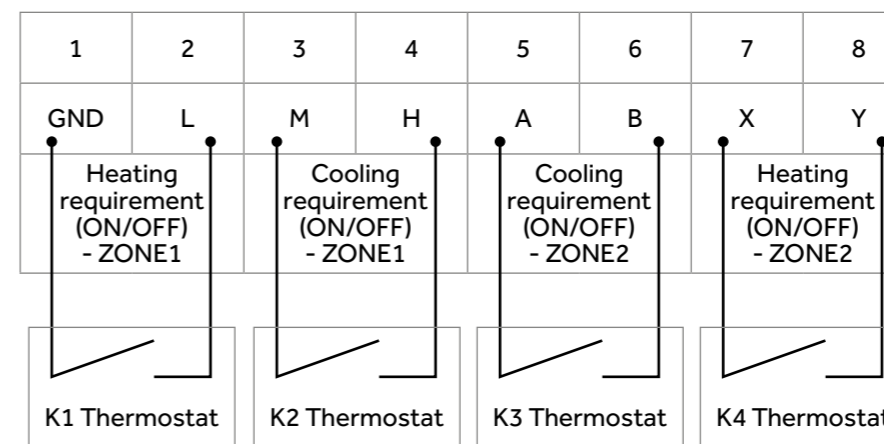

- 1) The contacts are all volt-free.
- 2) This set up is used when there are separate cooling and heating thermostats.
- 3) If you make a zone 1 contact from 1-2 the unit will start in heating mode zone 1, if you make a contact from 3-4 the unit will start in cooling mode.
- 4) If you make a contact from 5-6 the unit will start in cooling mode zone 2, If you make a contact from 7-8 the unit will start in heating mode zone 2.
- 5) You must not send a cooling and heating run signal at the same time.

9.1.2. THIRD-PARTY CONTROLLER SWITCH SIGNAL – TYPE 2

LESS COMMONLY USED



* All the connections on connection board 1, 2, 3 and 4 are with screw terminals.



Connection Board 1

1	2	3	4	5	6	7	8
GND	L	M	H	A	B	X	Y
Heat / Cool		Zone 1 ON/OFF		Zone 2 ON/OFF			

- 1) The contacts are all Volt free.
- 2) This set up is used when you are using a combined cooling and heating thermostat.
- 3) If you make a contact from 1-2 the unit is in cooling mode. If you break the contact from 1-2 the unit is in heating mode.
- 4) If you make a contact from 3-4 the unit will start in cooling or heating mode.
- 5) If you make a contact from 5-6 the unit will start in cooling or heating mode. Zone 2
- 6) If there's no run signal from request both Zone1 & Zone2, the unit will stop heating and cooling. DHW mode will continue.

Type 2
Simplified Connection Diagram

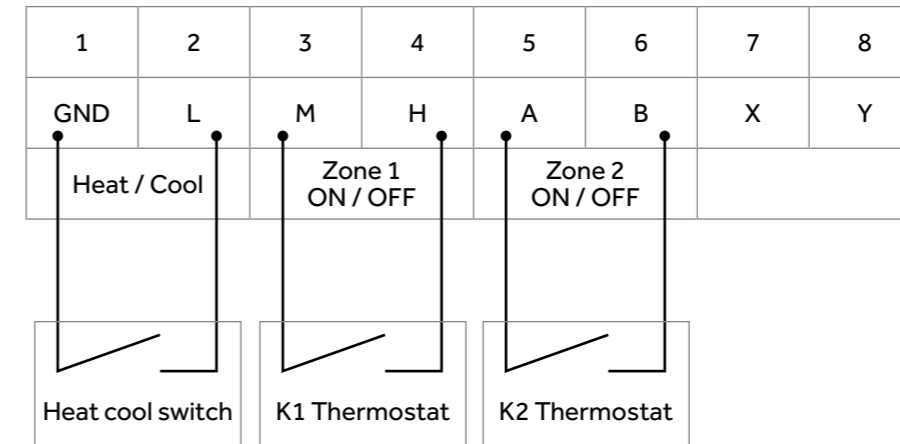

Heat cool switch: Switch-On for Cooling Mode, Switch-Off for Heating Mode

K1: Switch-On to start heating / cooling Zone 1. switch off the stop.

K3: Switch-On to start heating / cooling Zone 2. switch off the stop.

9.1.3. CONTROLLER SETTINGS

System Installation main settings

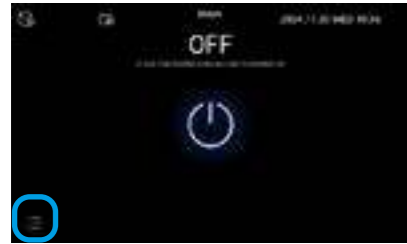

1



2



3

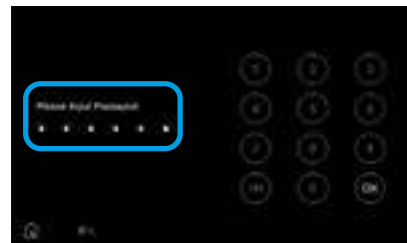

4 * Password "841226"



5

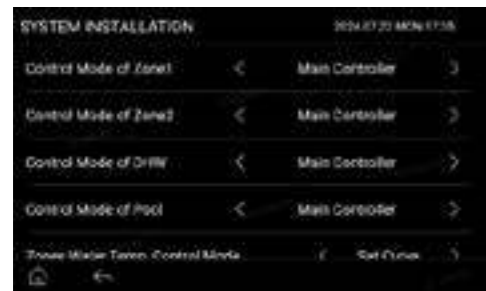

- ← **Third party controller** *SELECT THE CONTROL MODE FOR ZONE 1
- ← **Third party controller** *SELECT THE CONTROL MODE FOR ZONE 2
- ← Main Controller
- ← Main Controller

Function	Parameter Range	Settings
Control Mode of Zone 1	Main controller Third party controller	Third party controller
Control Mode of Zone 2	Main controller Third party controller	Third party controller

SCROLL DOWN 2 PAGES TO GET TO THIS MENU



- ← 60s
- ← **Type 1** * SELECT THE TYPE OF THIRD PARTY CONTROLLER

Function	Parameter Range	Settings
Third party Controller Type	Type 1 / Type 2	Type 1

* THE PARAMETERS THAT NEED TO BE MODIFIED ARE MARKED IN BLUE.

10.0. ANNEXES

10.0. ANNEXES

Preview ATW-A03N

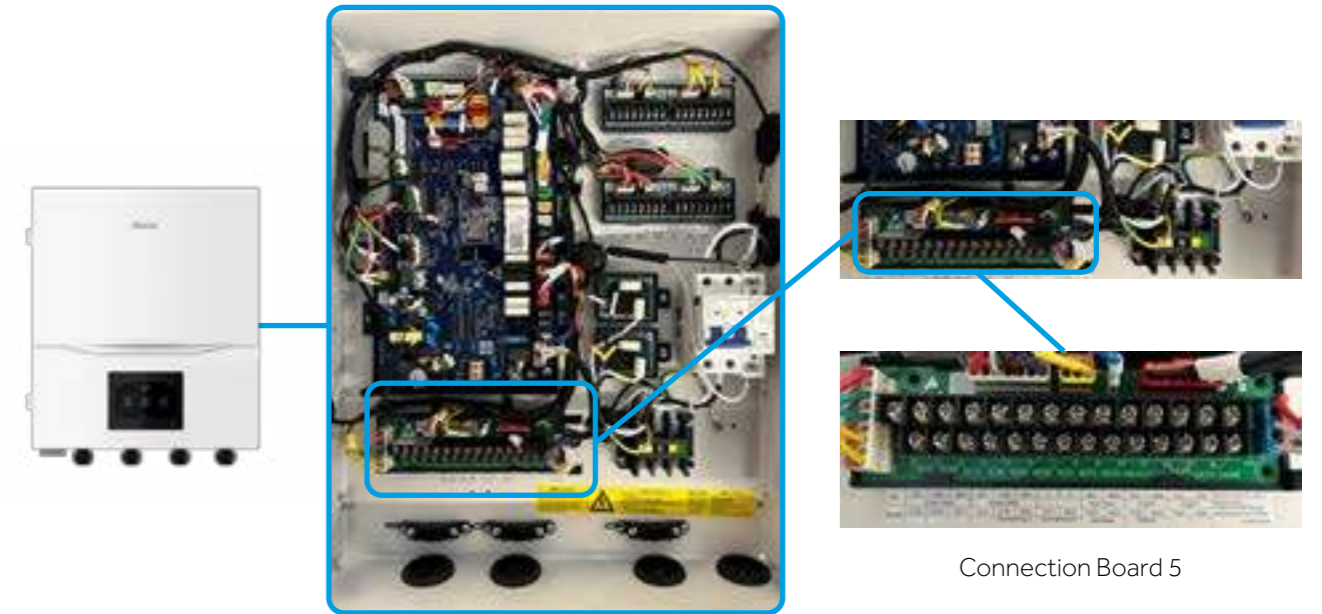
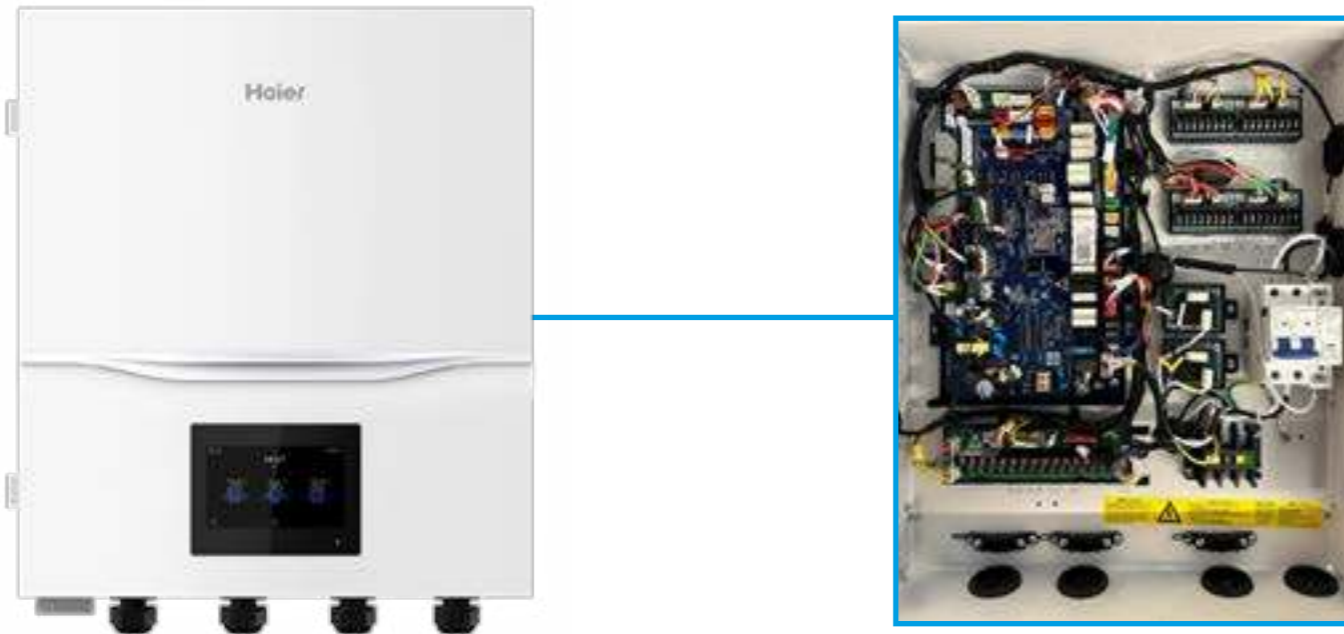

Connection Board 5

*** ALL THE CONNECTIONS ON CONNECTION BOARD 5 ARE WITH SCREW TERMINALS.**

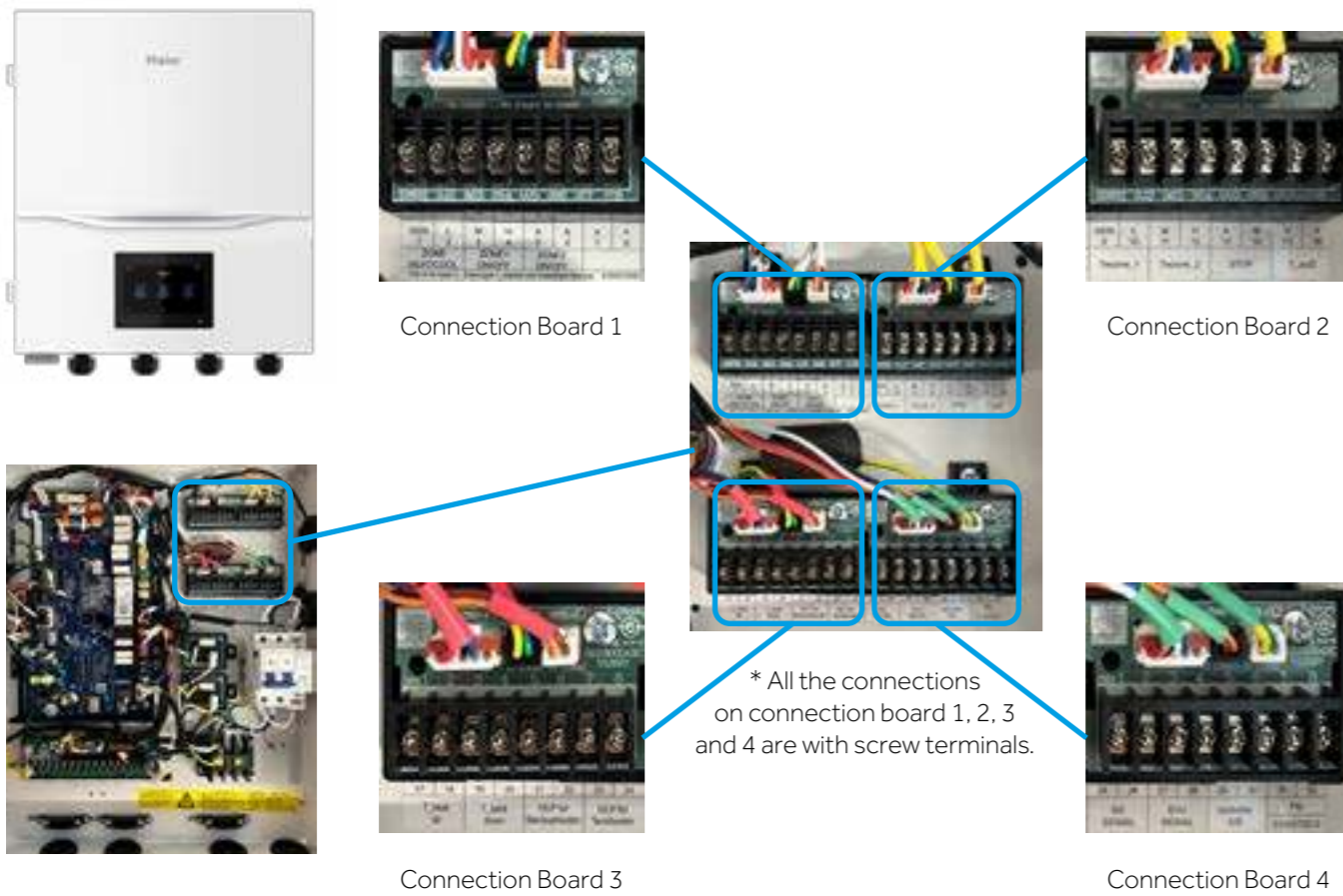

Connection Board 1

Connection Board 2



Connection Board 3

Connection Board 4

* All the connections on connection board 1, 2, 3 and 4 are with screw terminals.

10.0. ANNEXES

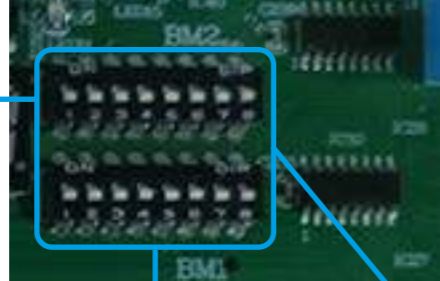
DIP Switch Setting - Single phase installation - 1ph-ODU

BIM 1

ON (1)

OFF (0)

1 2 3 4 5 6 7 8

BIM 2

ON (1)



OFF (0)

1 2 3 4 5 6 7 8

BM1_1	Capacity control	[1] Capacity control method 0 Normal control(default) 1 0~10V control(ATW-A02)
BM1_2	Outdoor unit model	[2] [3] [4] [5] Outdoor unit model 0 0 0 0 AW042MUGHA
BM1_3		0 0 0 1 AW062MUGHA
BM1_4		0 0 1 0 AW082MUGHA
BM1_5		0 0 1 1 AW102(N)MUGHA
		1 0 0 0 AW122(N)MXGHA
		1 0 0 1 AW142(N)MXGHA
		1 0 1 0 AW162(N)MXGHA
BM1_6	Power supply type	[6] Power supply type 0 Single phase 1 Three phase
BM1_7	Running mode	[7] [8] Outdoor unit running mode 0 0 Normal mode(default)
BM1_8		0 1 Turbo mode 1 0 Quiet mode 1 1 Test mode

	[1] [2] [3] Outdoor type selection
BM2_1	0 0 0 Monobloc(default)
BM2_2	0 0 1 Hydro split
BM2_3	Out 0 1 0 Hydro all in one
	door 1 1 Split
	type 1 0 0 Split all in one
	1 0 1 Reserved
	1 1 0 Reserved
	1 1 1 Reserved
BM2_4	Refrigerant type selection
	gera 0 R290(default)
	nt 1 R32
	type 1 R32
BM2_5	[5] [6] [7] [8] Reserved
BM2_6	0 0 0 0 Reserved(default)
BM2_7	Reserved
BM2_8	Reserved

DIP Switch Setting - ATW-A03 N

BIM 1

ON (1)

OFF (0)

1 2 3 4 5 6 7 8

BIM 2

ON (1)



OFF (0)

1 2 3 4 5 6 7 8

BM1_1	Indoor Type	[1] Indoor Type 0 ATW-A03(Default) 1 /
BM1_2	Cascade address	[2] [3] [4] Cascade address 0 0 0 Main unit(Default)
BM1_3		0 0 1 Sub unit 1#
BM1_4		0 1 0 Sub unit 2#
		0 1 1 Sub unit 3#
		1 0 0 Sub unit 4#
		1 0 1 Sub unit 5#
		1 1 0 Sub unit 6# 1 1 1 Sub unit 7#
BM1_5	Capacity	[5] [6] [7] [8] ODU capacity selection 0 0 0 0 AW042MUGHA
BM1_6		0 0 0 1 AW062MUGHA
BM1_7		0 0 1 0 AW082MUGHA
BM1_8		0 0 1 1 AW102(N)MUGHA 1 0 0 0 AW122(N)MXGHA 1 0 0 1 AW142(N)MXGHA 1 0 1 0 AW162(N)MXGHA

BM2_1	communication Address setting mode	[1] Outdoor communication address setting mode 0 Automatic setting (default) 1 Dip switch set address
BM2_2	Water tank sensor selection	[2] Water tank sensor selection 0 2 sensors, T_tank up and T_tank down (default) 1 Only 1 sensor, T_tank up
BM2_3	communication Address	[3] [4] [5] [6] [7] [8] Address 0 0 0 0 0 0 0 0 0#(default)
BM2_4		0 0 0 0 0 0 1 1 1#
BM2_5		0 0 0 0 0 0 1 0 2#
BM2_6		0 0 0 0 0 0 1 0 2#
BM2_7		...
BM2_8	...	

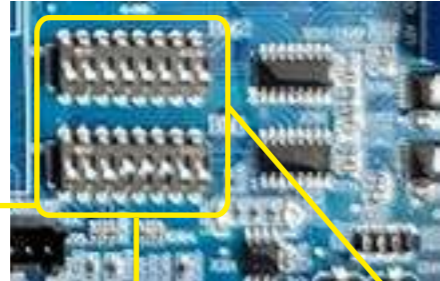
DIP Switch Setting - Three-phase installation - 3ph-ODU

BIM 1

ON (1)

OFF (0)

1 2 3 4 5 6 7 8

BIM 2

ON (1)

OFF (0)

1 2 3 4 5 6 7 8

BM1_1	Capacity control	[1] Capacity control method 0 Normal control(default) 1 0~10V control(ATW-A02)
BM1_2	Outdoor unit model	[2] [3] [4] [5] Outdoor unit model 0 0 0 0 AW042MUGHA
BM1_3		0 0 0 1 AW062MUGHA
BM1_4		0 0 1 0 AW082MUGHA
BM1_5		0 0 1 1 AW102(N)MUGHA
		1 0 0 0 AW122(N)MXGHA
		1 0 0 1 AW142(N)MXGHA
		1 0 1 0 AW162(N)MXGHA
BM1_6	Power supply type	[6] Power supply type 0 Single phase 1 Three phase
BM1_7	Running mode	[7] [8] Outdoor unit running mode 0 0 Normal mode(default)
BM1_8		0 1 Turbo mode 1 0 Quiet mode 1 1 Test mode

	[1] [2] [3] Outdoor type selection
BM2_1	0 0 0 Monobloc(default)
BM2_2	0 0 1 Hydro split
BM2_3	Out 0 1 0 Hydro all in one
	door 1 1 Split
	type 1 0 0 Split all in one
	1 0 1 Reserved
	1 1 0 Reserved
	1 1 1 Reserved
BM2_4	Refrigerant type selection
	gera 0 R290(default)
	nt 1 R32
	type 1 R32
BM2_5	[5] [6] [7] [8] Reserved
BM2_6	0 0 0 0 Reserved(default)
BM2_7	Reserved
BM2_8	Reserved

11.0. ADDING A HAIER THERMOSTAT HW-WA101ADK TO YOUR HEAT PUMP

11.0. THE HAIER THERMOSTAT

- The Haier thermostat has a number of features that make it the best choice for your Haier heat pump.
- 1- the Haier thermostat communicates directly with the heat pump optimising the heat pump for efficiency and comfort. It works with the heat pump to make it run at just the right temperature to keep your room comfortable.
- 2 - The Haier thermostat can be controlled by the HON app so you don't have to touch the screen, you can control your heating and hot water remotely.

Wiring the thermostat in

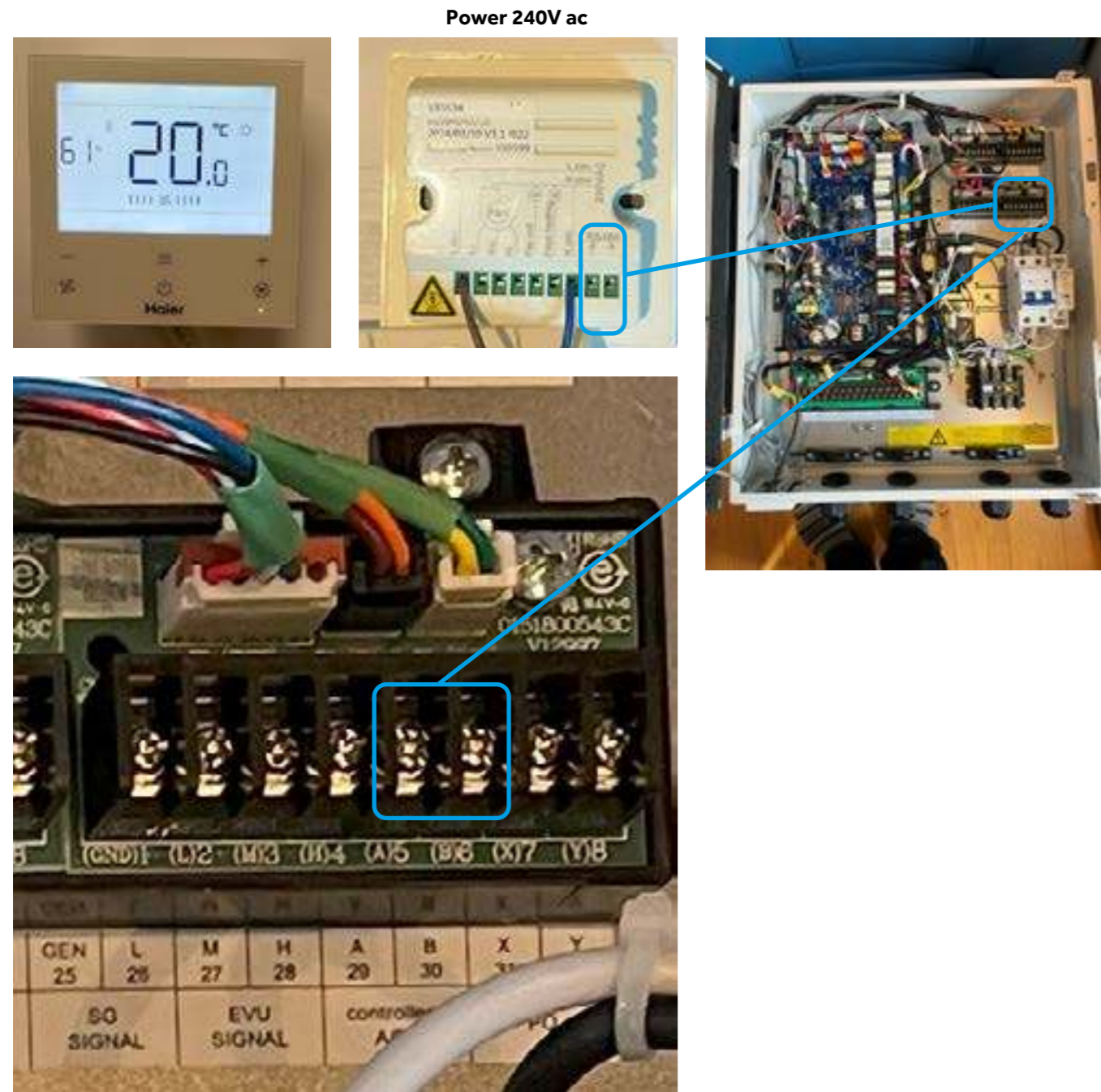

Wiring the thermostat in 2 zones

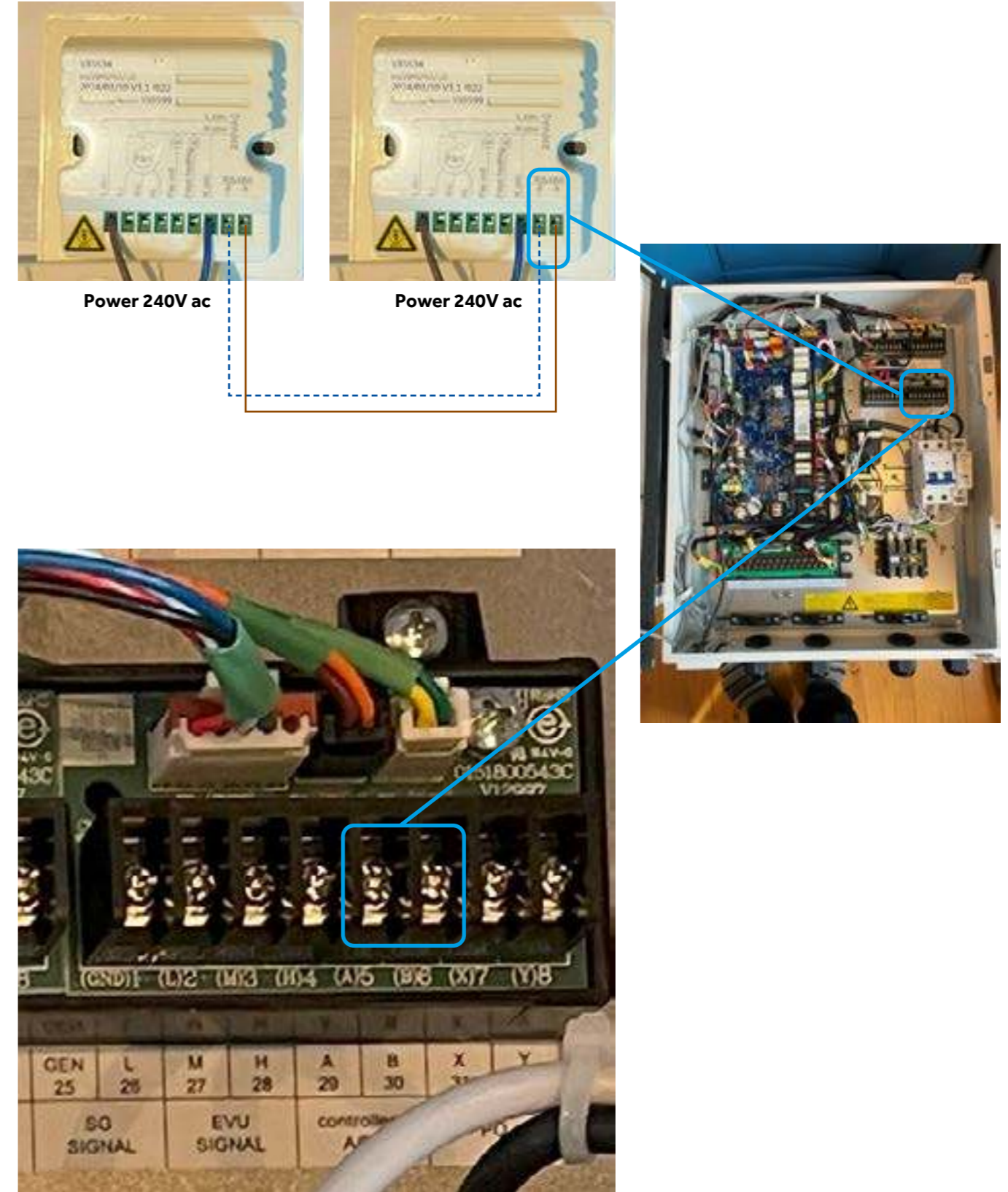

2.1.2. CONTROLLER SETTING

System Installation main settings



1



2



3

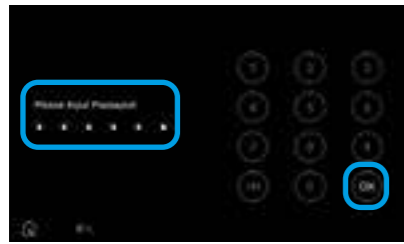

4 * Password "841226" OK



5

Equipment Installation main settings



← Thermostat

* SELECT THE CONTROL MODE FOR ZONE 1

Function	Parameter Range	Settings
Control Mode of Zone1	Main controller, Third party controller	Main controller

Settings on the thermostat

If you are using more than one thermostat you MUST rename them. Every thermostat needs its own address, 1,2 etc.

Power up thermostat, press any button so screen is lit.

Press and hold **(M)** for 10 seconds 01 will show this means address 01.

Use + or – key to change the address. Then press **≡** to confirm.

Settings on the thermostat part 2

If you are using more than one thermostat you MUST tell the heat pump what zone the thermostat is controlling, 1 or 2.

Power up thermostat, press any button so screen is lit.

Press and hold **(S)** for 10 seconds 01 will show this means address 01.

Use + or – key to change the address. Then press **≡** to confirm.

12.0. APPENDIX

12.0. APPENDIX

Recommended flow rates for each system

Unit kW	delta T	flow rate l/min	flow rate m ³ /hr	delta T	flow rate l/min	flow rate m ³ /hr
4	5	11.5	0.7	7	8.2	0.5
6	6	14.4	0.9	7	12.3	0.7
8	5	23.0	1.4	7	16.4	1.0
10	5	28.7	1.7	7	20.5	1.2
12	5	34.4	2.1	7	24.6	1.5
14	5	40.2	2.4	7	28.7	1.7
16	5	45.9	2.8	7	32.8	2.0

Capacity of pipework

The maximum recommended capacity for each pipe is as follows to avoid noise

At 5C delta T:

diameter mm	velocity m/s	delta t	flow rate m ³ /hr	flow rate l/min	kWs
6	1.2	5	0.1	1.3	0.5
8	1.2	5	0.2	2.6	0.9
10	1.2	5	0.3	4.4	1.5
12	1.2	5	0.4	6.6	2.3
15	1.2	5	0.6	10.5	3.6
22	1.2	5	1.4	23.1	8.0
28	1.2	5	2.3	38.8	13.5
35	1.2	5	3.6	60.1	20.9

At 7C delta T

diameter mm	velocity m/s	delta t	flow rate m ³ /hr	flow rate l/min	kWs
6	1.2	7	0.1	1.3	0.6
8	1.2	7	0.2	2.6	1.3
10	1.2	7	0.3	4.4	2.1
12	1.2	7	0.4	6.6	3.2
15	1.2	7	0.6	10.5	5.1
22	1.2	7	1.4	23.1	11.2
28	1.2	7	2.3	38.8	18.9
35	1.2	7	3.6	60.1	29.3

Minimum system volume Litres

Haier Heat pump	Model number	Minimum system volume Litres
4kW	AW042MUGHA	28.7
6kW	AW062MUGHA	43.1
8kW	AW082MUGHA	57.4
10kW	AW102MUGHA	71.8
12kW	AW122MX	86.1
14kW	AW142MX	100.5
16kW	AW162MX	114.8

Fuse sizes

Haier Heat pump Single Phase	Model Number	Fuse
4kW	AW042M/HUGHA	16 Amps
6kW	AW062M/HUGHA	16 Amps
8kW	AW082M/HUGHA	20 Amps
10kW	AW102M/HUGHA	20 Amps
12kW	AW122MXGHA	32 Amps
14kW	AW142MXGHA	32 Amps
16kW	AW162MXGHA	32 Amps
Haier Heat pump Three Phase		
10kW	AW10NMUGHA - AW102HUGHA	16 Amps
12kW	AW12NMUGHA - AW122H-VGHA	16 Amps
14kW	AW14NMUGHA - AW142H-VGHA	16 Amps
16kW	AW16NMUGHA - AW162H-VGHA	16 Amps
ATW-A03 N Indoor unit single phase		
All units	ATW-A03 N	13 Amps

